

Commissioning instruction
Access Professional 7.1.0
ASH 671-0 S
ASH 671-0 M

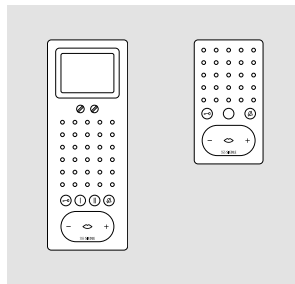
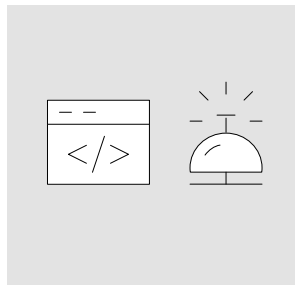
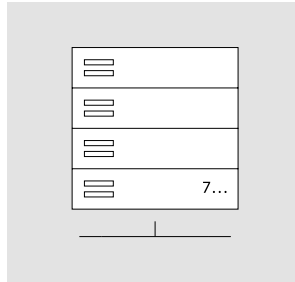

Contents

1 Safety remarks	3	Time profile	41
2 Installation and operating conditions	4	Directory	46
3 New in this version / Important changes	5	7 Configure devices	
4 System overview	6	Device types and recommended configuration order	47
A comparison of Access server variants	7	SIP Trunk	49
5 Commissioning		PABX gateway	52
Commissioning requirements	8	KNX Gateway	55
Connecting and switching on the server hardware	8	IP camera	57
Recommended commissioning sequence	9	Indoor devices	60
Commissioning possibilities	11	External devices	72
Device-specific settings	11	Software clients (ASC.../ASHT...)	79
6 Setting up the Access system		Software clients (Siedle app)	87
Initial setup	12	Door stations	95
Access system administration	14	8 Adding a member to the group	105
Navigation	15	9 Final assignments	106
Menu structure		10 Optional administration functions	
Access Professional	17	Log	107
Dashboard (start page)	18	User status	108
Basic parameters (optional)	19	Administrator / Password	109
System time settings (optional)	20	Backup/Restore	110
Network settings (optional)	21	11 As-delivered status (Server)	112
DNS (Domain Name System)	21	12 Connecting to external networks – Access Gateway	
Network adapter	22	Dashboard	114
DHCP server	23	Basic parameters	115
DHCP – Extended configuration area (DHCP server)	24	Network	116
Options	25	DNS (Domain Name System)	116
Licences	28	Network adapter	117
Function modules	30	DHCP server	118
Available function modules	30	DHCP – Extended configuration area (DHCP server)	119
Digital video decoupling	31	PABX gateway	122
Call number plans	33	Index	123
Permissions	34		
Folder	36		
Group	38		

Remarks

- This document is used as a guideline and selective reference work for the commissioning of Access Professional in an independent network and is designed to provide a brief overview of the most important points to be observed during initial commissioning.
- Please note that this document cannot cover all possible questions arising from the commissioning of your Access system. This document cannot replace an intensive advanced training course.
- This document supplements and is supplemented by the Planning and System Manual Access Professional.
- In addition to this document, you will find the current valid issue of the entire documentation in the download area under www.siedle.com

We accept no liability for modifications / additions, mistakes or printing errors.

Siedle service:
Access Service Center at the
Furtwangen plant
Tel. +49 7723 63-540
access@siedle.de

1 Safety remarks

Observe the safety instructions!

Read and observe the safety instructions and content of the following supplied documents before using the Access server hardware for the first time:

- Product information Access Server hardware
- Planning and System Manual Access Professional
- These commissioning instructions

Explain the content of the safety instructions and dangers inherent in using technically complex products to children and those requiring assistance in a way that is easily understandable.

Electrical voltage



Mounting, installation and servicing work on electrical devices may only be performed by a suitably qualified electrician.

Devices with 230 V connection

In accordance with DIN VDE 0100 part 410, section 411.1.3 attention must be paid to ensuring a safe separation between system lines and the mains voltage; i.e. system and mains cores must not be permitted to touch! The system line cable (extra-low safety voltage) must be stripped back by the minimum possible.

System update



During the update process, the power supply to the Siedle devices must not be interrupted, as this can result in damage. In this case, a repeat update is no longer possible, and the devices will have to be sent in for repair.

User access and passwords

The server operating system is delivered with default passwords. Assign new and secure passwords and keep these in a safe place. Forgotten passwords of the Access system software and the server operating system cannot be restored and the server operating system would have to be reinstalled and commissioned. For more information, see page 109.

All passwords are the responsibility of the installer/operator/customer.

Protect your property!

The Siedle App can be used from any location as a door release! Keep smartphones/tablets on which the Siedle App is activated safe from theft. Protect these devices against unauthorized usage with a code/password/fingerprint. Always use the latest protection mechanisms available for your smartphone/tablet.

Protect your network!

Only use up-to-date components and terminals in the network in line with the latest state of the art. Regularly update the operating systems of all components and terminals. Exchange obsolete components and terminals for up-to-date models. Use professional protective software (antivirus, firewall, ...) in all terminals. Issue secure passwords. Secure your network with the highest security standards available in the network. Protect your network against unauthorized attack from inside and outside.

Legal notice

Photographs of individuals taken without their knowledge may not be published or stored in publicly accessible video memory facilities.

Individuals who have been photographed without their knowledge are entitled to request that pictures be deleted based on the right of persons to their own likeness. Never store pictures of persons you do not know in social networks or send them by email to others/public groups. This will infringe their personal rights.

If stored images are used as part of private / criminal law proceedings or in a police investigation, this requires prior clarification with a lawyer or the responsible police authority. Systems with video cameras which are operated within the European Union and are aimed at a publicly accessible area or part of one, and film and record this, are subject to the EU General Data Protection Regulation (EU GDPR) as of May 25, 2018. It is the sole responsibility of the operator to operate such systems in accordance with data protection regulations.

Servicing

Statutory warranty conditions apply. If the device requires servicing, contact your specialist dealer or electrical installer.

2 Installation and operating conditions

The following requirements must be met in order for the Siedle Access system to operate properly:

- In the configured server operating system, install only the Siedle Access system.
- In addition, no other server services may be installed, as this can result in impaired performance of the server. (Rule: 1 server service per server operating system installation.)
- As server operating system installed without graphical user interface use Debian 11.
- The server hardware or virtual machine (from VMware vSphere 6) you have provided complies at least with the technically specified system requirements for the Access server.
- Only activate the services necessary for operating the Access server.
- Optional: Assign the server operating system the role of the DHCP server and where applicable the NTP server, if there is no DHCP and NTP server operating in your network or the Access system is operated in stand-alone mode.
- Assign a static IP address for the server operating system.
- The network infrastructure corresponds to the prescribed specification for Siedle Access.
- All network users of the Access server are operated using this network infrastructure.

3 New in this version / Important changes

Access system version

7.1.0

Access Professional 7.1.0 includes the following new features:

- New Siedle app functions:
 - Switching and signalling: Up to 44 buttons per Siedle app can be configured in the Access system management with any switching functions (e.g. open garage entrance, activate doormatic) or signalling functions (e.g. garage door is open, cellar light is on).
 - Storey call function: Storey calls can now also be received on your smartphone via the Siedle app.
 - Digital video decoupling: The video streams of all cameras which are operated in the Access system via an ATLC... (Access system cameras and system-free analogue cameras via AIVS...) can each be used individually for professional video surveillance (e.g. for continuous video recording) or for other display systems (e.g. building automation panels, for displaying the video feed of a door call). The function is subject to licence and can be optionally configured as a function module.
-

7.0.0

Access Professional 7.0.0 includes the following new features:

- New server operating system version: For Access Professional 7, the "Debian 11" server operating system is used.
 - New device type: IP camera (further information is available in the latest commissioning instructions)
 - New application licence "ALFC 270-0": For operating an IP camera on the Access Professional system. A licence is needed for each IP camera. The following performance features are available with system version 7.0:
 - Advanced concierge video functions (for client software ASC...): Additional video functions for the concierge software (concierge camera and door video forwarding) at the reception.
 - Camera observation (for video indoor call stations AHTV..., AHFV..., AVP... as well as client software ASC... and ASHT...): Manual camera selection from available IP cameras.
 - Camera scan (for client software ASC...): Automatic camera selection from available IP cameras.
 - New application licence "ALFM 270-0": To use additional system functions (such as lift control) on the Access Professional system from Version 7.0, the corresponding number of "ALFM 270-0" application licences is required. This is supplied as a function module (file). The number of licences required depends on the function.
 - Updating the TCM client for Access Professional: The TCM client (from Version 1.3.0) can only be used with Access Professional from Version 7.0 and the new touch control panels "JUNG Smart Control 8" and "JUNG KNX Smart Panel 8".
 - Application licence "ALFP 270-0": Only the new TCM client (from Version 1.3.0) can be used with the licence.
 - Improving the operating convenience of the system management.
 - Automatic check of the expiry date of the maintenance contract by the Access system software. A system upgrade is now possible at any time (24/7) via the Siedle webshop.
-

4 System overview

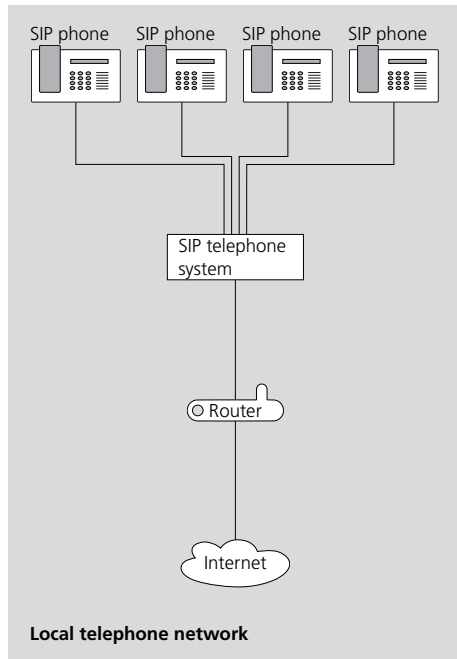
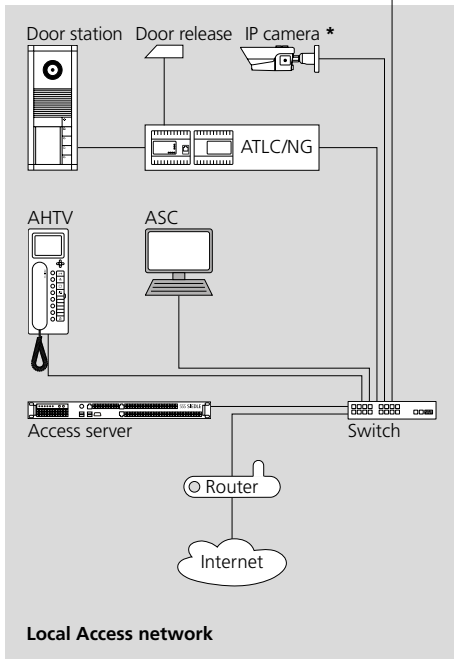
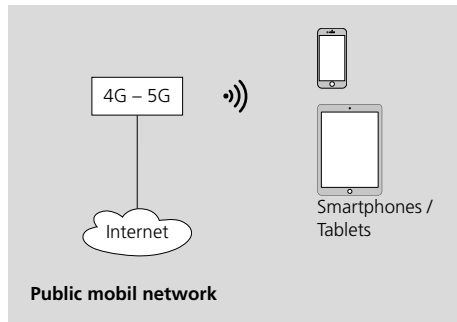
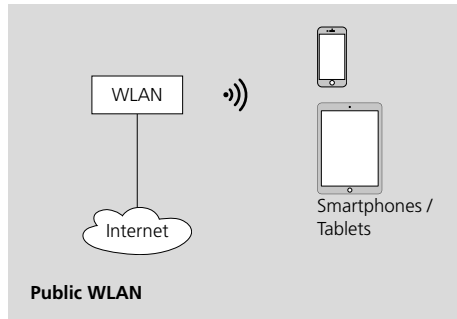
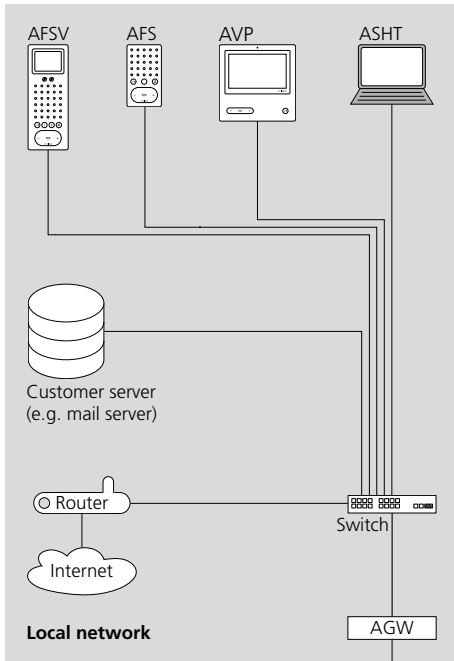

A comparison of Access server variants

Access server variant	Access Professional	ASH 671-0 M	ASH 671-0 S						
Versions	Software without server operating system/virtualization	Hardware server + pre-installed Access Professional	Hardware server + pre-installed Access Professional						
Access system version	Access Professional V 7...	Access Professional V 7...	Access Professional V 7...						
Possible number of users (User licences)	10–640	10–640	10–50						
Possible number of communication connections (simultaneously)	25 (Call signalling of up to 50 devices)	25 (Call signalling of up to 50 devices)	10 (Call signalling of up to 20 devices)						
Conditions	<ul style="list-style-type: none"> • Hardware server / virtualization • Server operating system Debian 11 • Network/VLAN as required • Indoor stations with POE supply • Software clients on terminals with network connection 	<ul style="list-style-type: none"> • Network/VLAN as required • Indoor stations with POE supply • Software clients on terminals with network connection 	<ul style="list-style-type: none"> • Network/VLAN as required • Indoor stations with POE supply • Software clients on terminals with network connection 						
As-delivered status	<ul style="list-style-type: none"> • The Access server must be installed and commissioned. • User and application licences are required for operating the Access system. • With the initial setup (basic configuration of the system before commissioning), a 30-day demo period begins after saving with restart, during which all system functions with a maximum number of devices can be used without restriction. • The server hardware/virtualization and server operating system must be provided by the customer and must be available. 	<ul style="list-style-type: none"> • The Access server is installed ready for operation and prepared for commissioning by the customer. • User and application licences are required for operating the Access system. • With the initial setup (basic configuration of the system before commissioning), a 30-day demo period begins after saving with restart, during which all system functions with a maximum number of devices can be used without restriction. • In the as-delivered status, the DHCP server of the Siedle Access Server is active. 							
		<p>Remark The standard login data for the server operating system of a Access Server Hardware (from ASH 671-0...) are:</p> <table border="1"> <thead> <tr> <th>User</th> <th>Password *</th> <th>SSH login</th> </tr> </thead> <tbody> <tr> <td>access</td> <td>SiedleAccessMain2015</td> <td>Active</td> </tr> </tbody> </table> <p>* Please change the password on initial commissioning, taking note of the security instructions.</p>		User	Password *	SSH login	access	SiedleAccessMain2015	Active
User	Password *	SSH login							
access	SiedleAccessMain2015	Active							

* IP camera: For more information, see page 57, 84

5 Commissioning

Commissioning requirements

In order to commission and set up the Access system, you must ensure that the following commissioning requirements are fulfilled:

- The Access system is documented (structures, administration of user rights, devices, correlations, directories, call numbers (2-5 digits), information on call number plans etc.)
- User and application licences are required for operating the Access system.
- Access licences can only be ordered from Siedle via Access Certified Partners at the start of commissioning because the Hardware ID (XML file) exported from the Access server is required for this.
- The network infrastructure has been completely installed and is fully functional.
- All switches required in the network and for the Access network are ready for operation.
- All door stations are correctly connected to the ATLC and ready for operation, but not yet linked to the network.
- All hardware indoor stations are prepared for installation or installed, but not yet linked to the network.
- PoE (Power over Ethernet) is available at all network connections for hardware indoor stations (PoE switch or PoE injector).



Note!

- In the as-delivered status of the Siedle Access system as a hardware variant (ASH...), the DHCP and NTP server is active.
- If the IP address of the Access system has to be changed, first change the the IP address and the DHCP server settings and then connect the terminals to the system. Otherwise, the terminals will be assigned the wrong IP address and will have to be restarted.
- In large systems, it is advisable following the basic configuration to link the terminals (if available) block by block in logically cohesive groups to the server, in order to allow them to be configured in the Access server administration.
- For commissioning support and documentation purposes, we recommend using the Siedle Access device protocol. The latest version can be found in the download area at www.siedle.com

Connecting and switching on the server hardware

Irrespective of whether the server hardware was supplied by Siedle, or whether the customer's own hardware is being used, this must be connected to the power supply and the network.

Remark: Operate the Siedle Access server hardware exclusively within the admissible ambient temperature of 10 °C to +50 °C.

Procedure with Siedle server hardware:

- 1 Set up the server hardware or mount the server hardware in the required position in the server cabinet.
- 2 Connect the server hardware to the power supply.
- 3 Connect the server hardware to the Access network.
- 4 Switch on the server hardware.
- 5 Make available a computer for configuration/set-up of the Access system and connect it to the Access network.

Remark

- The Access server hardware is already pre-installed and ready for configuration/set-up. The Access server hardware can be reached as standard over <http://192.168.1.1>

Procedure with customer's own server hardware:

- 1 Set up the server hardware or mount it in the required position in the server cabinet.
- 2 Connect the server hardware to the power supply.
- 3 Connect the server hardware to the Access network.
- 4 Make available a computer for configuration/set-up of the Access system and connect it to the Access network.
- 5 Switch on the server hardware.
- 6 Install the server operating system and the Access system software.

Note

An Internet connection is required to install the Linux version of the Access system on your own server hardware/virtualization.

Recommended commissioning sequence

Plan and document the Access system in detail	see Planning and System Manual Access Professional
Install and set up the server operating system (only with Access Professional as software variant)	see Access Wiki in the service portal at www.siedle.com
Initial setup (basic configuration before commissioning)	Page 12
Optionally: Configuring advanced network settings	Page 21
Optionally: Configuring advanced system time settings (NTP)	Page 20
Optionally: Configuring and storing basic parameters	Page 19
Order and import licences	Page 28
Optionally: Import function modules	Page 30
Optionally: Configuring call number plans	Page 33
Configuring folder structure	Page 34 / 36
Optionally: Configuring groups (without group members)	Page 38
Optionally: Configuring time profiles	Page 41
Optionally: Configuring individual directories/contacts	Page 46
Optionally: Configuring the Access Gateway	Page 113
Optionally: Configuring the telephony connection (SIP Trunk / PABX Gateway)	Page 49
Optionally: Configuring a KNX gateway / KNX addresses	Page 55
Optionally: Configure IP cameras	Page 57
Configure end devices (hardware, software, app)	Page 60
Optionally: Adding a member to the group	Page 105
Carry out final tasks	Page 106
Changing password (Siedle Access system administration)	Page 109

5 Commissioning

Recommended commissioning sequence

Device commissioning

Depending on the size (number of devices) of the Access system and the situation on site (e.g. building size on the customer's premises), select the best procedure to use for device commissioning at your own discretion. Possible procedures:

Using the MAC address label

With all indoor stations and door controllers, an additional MAC address label for the respective device is included in the scope of supply.
A barcode scanner can also be used to enter the MAC addresses in a list.

This label should be used for documentation purposes and for commissioning support in the Siedle Access device protocol (e.g. handover protocol for the customer).
The Siedle Access device protocol is located in the Siedle download area at www.siedle.com

Procedure	Description	Commentary
Prepared configuration	Local provisional set-up (workshop) for commissioning and configuration of the Access system and the Access devices prior to actual installation on the customer's premises.	Suitable for all sizes of Access system in buildings in which the final installation is only possible shortly before closure, buildings with a large number of security areas and access restrictions or where communication possibilities are restricted. The preparatory configuration calls for a fully completed detailed plan and a structured and documented work method. In addition, all pre-configured devices must have been logically and traceably inscribed.
Complete configuration	Link all devices to the already set up Access system and configure the devices.	Suitable for small Access systems with a simple structure and few or only few identical Access devices, and buildings with no or minimal internal access restrictions.
Block-by-block configuration	Systematically connect the devices one block at a time to the already set up Access system in order to configure them in blocks.	Suitable for medium and very large Access systems with complex structures which have few or few identical Access devices within one or more users or groups, as well as buildings with no or only minimal internal access restrictions.
Serial configuration	Systematically connect the devices in series to the already set up Access system in order to configure them individually.	Suitable for medium and very large Access systems with complex structures which have few or few identical Access devices within one or more users or groups, as well as buildings with no or only minimal internal access restrictions.

Recommendation

- Only ever commission several devices simultaneously if these can be clearly differentiated by their device type / MAC address and if assignment to the user is clear.
- Commission devices individually in series if you are dealing with a large quantity of identical device types which need to be commissioned.

Background

All newly detected devices are located in the **Users and Devices** menu in the **Unconfigured Devices** folder. If there are a large number of identical devices, the identification work increases, as does the effort involved in configuration and assignment of the individual devices. With the Access system administration and the search field, devices can be found by their MAC address.

Device-specific settings

In the system, it is possible to select a language for all Access terminals at the Access system. The system language and setting of the bell and voice volume can be centrally configured at the Access system. These settings can be locally individually changed at the terminals.

Commissioning possibilities	Distribution of tasks	Remarks
Commissioning on site with 2 persons	<ul style="list-style-type: none"> • Person 1 carries out the final installation, commissioning and function test of the device at the relevant device location. • Person 2 carries out the relevant device configuration at the Access system. 	<p>Suitable for large Access systems in large buildings or buildings without functioning WIFI.</p> <p>Mobile wireless phones or wireless devices are necessary for communication between the two people.</p>
Commissioning on site with 1 person	<ul style="list-style-type: none"> • Person 1 prepares the Access system for device commissioning. • The next step is final assembly, commissioning of the device, configuration at the Access system using a mobile computer at the relevant device. Then the device is function tested on site. 	<p>Suitable for small to medium Access systems or Access systems in small to medium buildings.</p> <p>WIFI or LTE/UMTS access to the Access system is necessary in order to allow device configuration for the respective devices to be carried out at the Access system.</p>
Commissioning with 1 person and prepared Access system	<ul style="list-style-type: none"> • Person 1 commissions the Access system and starts the network infrastructure. • In the next step, final assembly, commissioning and function testing of the preconfigured device take place on site. 	<p>Suitable for small to medium Access systems or Access systems in small to medium buildings.</p> <p>Requirement: Completed and released detail planning of the Access system, as well as unambiguous marking and documentation of the pre-configured devices.</p>

6 Setting up the Access system

Initial setup

During initial setup, you configure basic system settings and prepare Access Professional for commissioning.

A wizard guides you through the initial setup in just a few steps, in which you make the following settings:

Network	<ul style="list-style-type: none">• Configuration of the network adapters• DHCP server• DNS server
---------	--

Time zone	<ul style="list-style-type: none">• Time zone
-----------	---

Access data	System management password for the "admin" user account
-------------	---

Remarks

- All settings made can be changed at any time in the system management after the initial setup has been completed.
- When the initial setup is complete, all settings are saved and the system is restarted.
- After the restart, the end devices and interfaces can be commissioned immediately via the system management.
- You can access the system management via web browser under the IP address and the login data that you entered during the initial setup.

Call up initial setup

Access server variant ASH 671-0 S/M

Access to the system:

The Siedle Access servers can be reached in the network as standard over <http://192.168.1.1>

Procedure

- 1** Connect the commissioning computer directly to the Access server by switch.
- 2** Start the browser on the commissioning computer.
- 3** Enter the pre-configured IP address of the Access server.
- 4** The start page for the initial setup of the Access system is called up and opens in the browser window.
- 5** Select the operating language for the initial setup.
- 6** Start the initial setup.

Customer's own server with installed Access system

Access to the system:

The customer's own server operating system can be reached in the network under the individually assigned static IP address.

Procedure

- 1** Connect the commissioning computer directly to the Access server by switch.
 - 2** Start the browser on the commissioning computer.
 - 3** Enter the individually assigned IP address of the server operating system.
 - 4** The start page for the initial setup of the Access system is called up and opens in the browser window.
 - 5** Select the operating language for the initial setup.
 - 6** Start the initial setup.
-

Configuration table "Initial setup"

Parameters	Explanation	Configuration
IP configuration	Option how to assign the IP address for the network adapter.	<ul style="list-style-type: none">• Option "Static IP" is set: The configuration is done manually via the system administration. The Access system is usable as a DHCP server.• Option "IP from DHCP" is set: This network adapter obtains the complete IP configuration from a DHCP server on the network. The Access system is not usable as a DHCP server!
IP address	IPv4 address of the network adapter.	IPv4: e.g. 192.168.178.100
Subnet mask	Subnet mask of the network to which this network adapter is connected.	IPv4: e.g. 255.255.255.0
Default gateway	IP address of the default gateway of the network to which this network adapter is connected. If the Access system is to be accessible via the Internet (e.g. for the Siedle App) or via other networks, you must enter the correct IP address for the standard gateway (router).	IPv4: e.g. 192.168.178.254
DHCP server	Option whether the Access system may assign IP addresses in the network as DHCP server. This option can only be used if the IP configuration was done manually.	<ul style="list-style-type: none">• Option "For this network adapter" is set: The Access system assigns the IP addresses within the network.• Option "For this network adapter" is not set: A DHCP server in the network assigns the IP addresses or all network clients are configured manually.• IP Pool, Start: First IP address of an IP address range (IPv4: e.g. 192.168.178.150) that may be assigned within the network via DHCP.• IP Pool, End: Last IP address of an IP address range (IPv4: e.g. 192.168.178.200) that may be assigned by DHCP within the network.
DNS server	IP address of the DNS server of the network to which this network adapter is connected. If you do not use the Access system exclusively in island mode, but integrate it into an existing network (e.g. domain), you must enter the correct IP address for the DNS server.	IPv4: e.g. 192.168.0.1
Time zone	Time zone selection for determining the time zone and calculating the "Server time" with which the Access system is operated.	e.g. for Germany: "+01:00 Central European Time - Berlin, Hamburg, Munich, Köln"

6 Setting up the Access system

Access system administration

Access server variant ASH 671-0 S/M

Access to the system:

The Access system management can be accessed via the IP address assigned during the initial setup.

Procedure

1 Connect the commissioning computer directly to the Access server by switch.

2 Start the browser on the commissioning computer.

3 Enter the IP address of the Access server that you assigned during initial setup.

4 The login screen of the Access system is accessed and opens in the browser window.

5 Select the operating language of the Access System Administration.

6 Log in to the Access system (account name: "admin" / password: [as assigned during initial setup]).

Customer's own server with installed Access system

Access to the system:

The Access system management can be accessed via the IP address assigned during the initial setup.

Procedure

1 Connect the commissioning computer directly to the Access server by switch.

2 Start the browser on the commissioning computer.

3 Enter the IP address of the Access server that you assigned during initial setup.

4 The login screen of the Access system is accessed and opens in the browser window.

5 Select the operating language of the Access System Administration.

6 Log in to the Access system (account name: "admin" / password: [as assigned during initial setup]).

Additional functions at the login window

There is one active link provided at the login window:

"Downloads/Licences": Here, you have dual-language access to information on system requirements and licence agreements, to the Access software clients (Access Software Concierge and Access Software In-house telephone) and to necessary Windows software components for operation at Windows PCs.

Navigation

Dashboard (start page)

After every login at the Access system, the Dashboard (start page) is displayed.

Administration graphic user interfaces

The administration interface is divided into three areas:

1 Navigation area

The navigation area contains the menu items "System maintenance" and "Users". Each menu item contains further submenu items. Each click on a submenu item opens a corresponding window in the content area.

When importing function modules (e.g digital video decoupling), additional menu items (such as "Interfaces") may appear in the navigation area.

2 Header area

The search field and the button for the user account are located in the header area.

3 Content area

The menu items are always configured in the content area. A separate window with its own tab page and heading opens in the content area for each accessed menu item. The actively opened window is indicated by a blue coloured tab.

Remarks

- The dashboard updates itself automatically at regular intervals (usually approx. every 5 seconds; depending on browser accuracy).

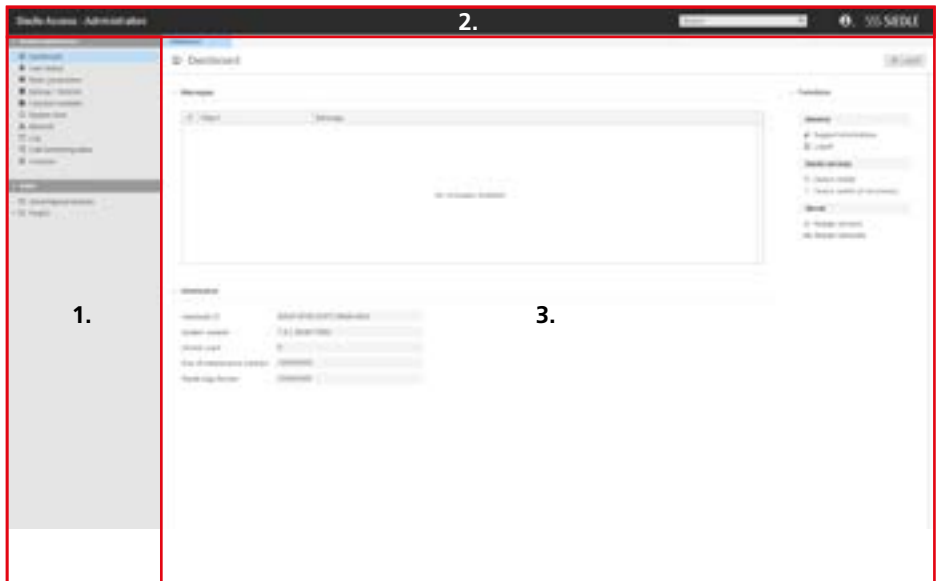

6 Setting up the Access system

Navigation

System maintenance

Submenu items	Contents
Dashboard	Messages, Information, System functions
User status	Status of devices, Call groups, Gateways, ...
Basic parameters	Configuration: System language of all devices, System services and assigned network adapters, Operating parameters of the system (durations)
Backup/Restore	Backup and restore of the Access system configuration without the initial setup configuration (network, time zone, access data)
Function modules	Upload or delete the function module (file) for extending the Access Professional system with additional useful system functions.
System time	Configuration: Server time, time zone and time synchronisation
Network	Configuration: Network settings (IP configuration of all network adapters, DNS server, DHCP server service)
Log	Logging of the changes made to the Access system via the administration interface
Call number plans	Creation of call profiles and dialling rules
Licences	Exporting the hardware ID, Licence import, Listing of the available system licences

Users

Submenu items	Contents
Unconfigured Devices	Unassigned Siedle devices in the Access system
Project	Configuration of the Access communication structure (e.g. folders, administrators, groups, time profiles, devices, address books, ...)

Header area

Operating element	Contents
Search field	Search for objects within the Access system database. Search options: Name, Description, Call Number, MAC Address, ...
Button for the user account	Logging off, showing notifications, settings (Configuration of the logged-in administrator): Name, description, username and password

Header area (Content page)

Operating element (menu-dependent)	Contents
Refresh	Refreshing the view
Export	Exporting the hardware ID
Device restart	Restarts all Siedle Access hardware devices.
Device restart (if necessary)	Restarts Siedle Access hardware devices for which a change has been made and saved.
Add	Adding a new object to a folder
Lists	Listing of available contacts, cameras and switching list of an indoor unit
Delete (Dust bin icon)	Deleting device or list entries (e.g. Logfile)
Restart (services/hardware)	Restarting services or restarting the server hardware
Permissions	Accessing the permissions management of the respective object
Save	Saving the configuration change

Menu structure Access Professional

Menu level 1	Menu level 2	Menu level 3	Page
System maintenance	Dashboard		18
	User status		108
	Basic parameters		19
	Backup/Restore		110
	Function modules		30
	System time		20
	Network		21
	Log		107
	Call number plans		33
	Licences		28
	Interfaces *		19, 30
Users	Unconfigured Devices		36
	Project	Administrator	109
		Directory	46
		Door station (ATLC...)	95
		Group	38
		IP camera	57
		JUNG Panel (External devices: JUNG Smart Control 8, JUNG KNX Smart Panel 8)	72
		KNX gateway (External device)	55
		Folder	36
		AFS/AFSV/AHF/AHFV/AHT/AHTV 870-0 (Indoor devices)	60
		Siedle App (Software client)	87
		ASC/ASHT 170 (Software client)	79
		AVP 870 (Indoor device)	60
		SIP telephone (External device)	72
		SIP Trunk (External device)	49
		PABX gateway (External device)	52
		PABX phone (External device)	72
	Time profile	41	

* This menu is only shown after a function module which requires this menu for configuration purposes has been imported.

6 Setting up the Access system

Dashboard (start page)

Each session starts with the dashboard. The dashboard displays informations and relevant messages of the Access system, and provides important functions.

Messages

In the Messages area, the system displays a list of warning messages for system objects (folders, groups, time profiles, devices, and address books). By clicking on the respective object name in the list, the corresponding configuration page of the object opens.

Information

Contents	Explanation
----------	-------------

Hardware ID	The hardware ID is required for ordering access licenses and is generated from different hardware and software components. If you change significant parts of your hardware server or replace the entire hardware server, the hardware ID of the system can change and all previous licenses must be converted.
-------------	---

System version	Installed software version and build number of Access Professional
----------------	--

Device count	Number of devices in the Access system (door stations, indoor stations, access software clients, third-party devices (e.g. VoIP telephones))
--------------	--

End of maintenance contract	Point at which the maintenance contract ends. All releases with the major release valid at this point and all associated minor/micro releases can be installed free of charge at any time. The initial term of the maintenance contract is 1 year and can be extended for a fee. The Access system software automatically checks the expiry date of the maintenance contract. A system upgrade is now possible at any time (24/7) via the Siedle webshop.
-----------------------------	---

Siedle app service	Connection status between Access server and Siedle app service (cloud).
--------------------	---

Functions

Function	Explanation
----------	-------------

Support informations	Provides important information (system configuration and log files) about the Access system for download in case of a support case.
----------------------	---

Log off	Logs the user off from the Access system management.
---------	--

Device restart	Restarts all Siedle Access hardware devices. The access server and access software clients, Siedle apps or third-party devices remain in operation unchanged
----------------	--

Device restart (if necessary)	Restarts only those Siedle Access hardware devices that require a restart due to a configuration change. The Access server and Access software clients, Siedle apps or third-party devices remain in operation unchanged.
-------------------------------	---

Restart services	Restarts the Access system services (without server operating system and hardware)
------------------	--

Restart hardware	Performs a complete system restart
------------------	------------------------------------

Basic parameters (optional)

In the Basic parameters menu, you can customise the pre-configured operating parameters (durations) for the operation of the Access system.

Configuration table "General"

Operating parameters	Explanation
System language	Selection of the system language of the Access indoor units (10 languages). The selected system language can be subsequently changed at the Access indoor units.
Network adapter	List of all network adapters detected by the Access system. Detected network adapters must have been configured in the server operating system and can be physical (e.g. hardware-side network card in the device) or logical (e.g. software-side network connection via VPN).
IPv4	Activating/deactivating IPv4 operation for this network adapter
Client	Selecting the network adapter for operating the software clients
Telephony	Selecting the network adapter for operating the door stations, indoor units and external devices

Configuration table "Durations (door)"

Operating parameters	Explanation	Operating range
Max. ring duration	Maximum duration of the call signalling of a door call	5 – 60 Sec.
Max. call duration	Maximum connection time of a door call	1 – 1440 Min.
Video follow Up	Time how long the live video image is displayed on the Siedle indoor unit after the call has ended	0 – 15 Sec.

Configuration table "Durations (general)"

Operating parameters	Explanation	Operating range
Max. ring duration	Maximum duration of call signalling for an internal/ external call	5 – 120 Sec.
Max. call duration	Maximum connection time of an internal/external call	10 – 1440 Min.

Configuration table "Durations (lists)"

Operating parameters	Explanation	Operating range *
Video memory, max.	Maximum storage time of an image in the video memory	1 – 120 Days
Call list, max.	Maximum storage time of a call list entry in the call list	1 – 120 Days
Voicemail, max.	Maximum storage time of a voicemail in the voicebox	1 – 120 Days

* Contents are deleted when the maximum storage period is reached!

6 Setting up the Access system

System time settings (optional)

In the "System time" menu, you can adjust the parameters configured in the initial setup for the operation of the Access system and make additional settings.

Remarks

- Time is preferably supplied to the Access system via time server (NTP server). Alternatively, the timer (hardware clock) of the server hardware/virtualisation can be used.
- Any number of time servers can be stored.
- A time server can be stored either with an IP address or DNS name.

Configuration table "General"

Parameters	Explanation	Configuration
Server time	Time set in the Access system.	–
Browser time	Time set on the computer used to access the system management.	–
Time zone	Time zone selection for determining the time zone and calculating the "Server time" with which the Access system is operated.	e.g. for Germany: "+01:00 Central European Time - Berlin, Hamburg, Munich, Köln"

Configuration table "Time synchronisation"

Parameters	Explanation	Configuration
Mode	Option for how the Access system's server time is synchronised.	<ul style="list-style-type: none">• Option "Automatic updates via time server" is set: Time synchronisation takes place automatically via time server.• Option "Use hardware clock" is set: Time synchronisation is done manually and must be checked regularly for deviations.
Time server	List of the time servers or time server pool for automatic updating of the Access system server time.	<p>A time server in the local network or Internet is displayed as an IPv4 address or DNS name (e.g. IPv4: "10.20.30.40" or DNS name: "pool.ntp.org").</p> <h4>Functions</h4> <ul style="list-style-type: none">• „New“: Manually create a time server with IP address or DNS name.• „Edit“: Manually edit the IP address or DNS name of an existing time server.
NTP status	Status of the automatic time synchronisation of the server time used in the Access system.	–

Network settings (optional)

In the "Network" menu, you can adjust the network adapter parameters configured in the initial setup for the operation of the Access system and make additional settings.

The IP address assignment for Siedle door controllers and indoor units (ATLC/AFS/AFSV/AHF/AHFV/AHT/AHTV/AVP...) in the Access system is always carried out via DHCP.

DNS (Domain Name System)

- In the "DNS (Domain Name System)" area, the central configuration for the DNS server(s) for all of the Access server's network interfaces is carried out.
- The DNS supply can be configured either automatically (via DHCP) or manually.
- A DNS server address can only be configured manually if the option "Obtain DNS server address automatically" is not set.
- Manually configured DNS server address(es) are deleted if the option "Obtain DNS server address automatically" is set.

Important!

- Configuration changes are only saved permanently with "Save".
- With every change made, the font colour of the page tab changes to red and "Save" is active.
- After saving, the Access system must be restarted.
- A device restart is possible on the same page or via the dashboard.

Configuration table "DNS (Domain Name System)"

Parameters	Explanation	Configuration
Mode	Option how to configure the DNS: <ul style="list-style-type: none">• Option "Obtain DNS server address automatically" is set: The DNS configuration is done automatically via DHCP.• Option "Obtain DNS server address automatically" is not set: The DNS configuration is done manually.	e.g. option is set
DNS server	<ul style="list-style-type: none">• List of the DNS servers that were created manually or automatically via DHCP.• DNS servers assigned via DHCP are marked with "(dhcp)" behind the displayed IP address. Functions <ul style="list-style-type: none">• „New“: Manually create a DNS server with IP address.• „Edit“: Manually edit the IP address of an existing DNS server.	IP address of the DNS server (only configure if available – IPv4: e.g. 192.168.178.1)

6 Setting up the Access system

Network settings (optional)

Network adapter

- In the “Network adapter” area, the IPv4 configuration of the respective network adapter is carried out.
- Each detected network adapter is displayed separately.
- For network adapters with an active network connection, the status display changes from yellow to green.
- Ensure that you have selected the correct network interface during configuration.

Remarks

- Detected network adapters can be physical (e.g. hardware-side network card in the device) or logical (e.g. software-side network connection via VPN).
- Each network adapter can be configured for IPv4 in the “Network adapter” and “DHCP server” area.
- Which network adapter is to be used for which Access system service (Client or Phone) is configured in the “Basic parameters” menu.
- Door stations, indoor devices and software clients from Siedle can currently only be used in IPv4 operation.
- If several network adapters are used, the Access system administration is accessible via any network connection configured for this purpose.

Configuration table “Network adapter”

Parameters	Explanation	Configuration
Name	Freely selectable naming of the network interface. The system assigned name is displayed beside the input field (e.g. “ens192”).	e.g. Access network
IP configuration	Option how the IP configuration for this network interface is done: <ul style="list-style-type: none"> • “Fixed IP” option is set: The IP configuration of this network adapter is done manually. • “IP from DHCP” option is set: The network adapter obtains the complete IP configuration from the network through a DHCP server. • “Not configured” option is set: This network adapter is not configured. 	e.g. “IP from DHCP”
IP address	IPv4 address of this network adapter	IPv4: e.g. 192.168.178.100
Subnet mask	Subnet mask of the network to which this network adapter is connected.	IPv4: e.g. 255.255.255.0
Default gateway	IP address of the default gateway of the network to which this network adapter is connected. If you want the Access system to be accessible via the Internet or other networks (e.g. Siedle app) and not only in island mode, you must enter the correct IP address for the default gateway or router .	only configure if available – IPv4: e.g. 192.168.178.254

DHCP server

- With this option, the DHCP configuration (IPv4) of the associated network adapter is carried out.
- A separate DHCP server can be configured for each network adapter.
- This option is only configurable if the option "Static IP" is selected for IP configuration and the option "For this network adapter" is set.
- Ensure that you have selected the correct network adapter.

Configuration table "Network adapter"

Parameters	Explanation	Configuration
DHCP server	Option for whether the Access system may assign IP addresses in the network as DHCP server: <ul style="list-style-type: none">• Option "For this network adapter" is set: The Access system assigns the IP addresses within the network.• Option "For this network adapter" is not set: A DHCP server in the network assigns the IP addresses or all network clients are configured manually.	e.g. option is set
IP pool, start	First IP address of an IP address range (IPv4) that may be assigned within the network via DHCP.	IPv4: e.g. 192.168.178.150
IP pool, end	Last IP address of an IP address range (IPv4) that may be assigned by DHCP within the network.	IPv4: e.g. 192.168.178.200
DHCP	<ul style="list-style-type: none">• Extended configuration area for configuring the DHCP server. –• An automatic adjustment is always made for the proper operation of the Access end devices operated on the Access server.• Please check the settings made in full.	

6 Setting up the Access system

Network settings (optional)

DHCP – Extended configuration area (DHCP server)

- The extended configuration area can be called up via the “Options” button.
- In this area, a detailed configuration of the DHCP server is possible.

General

- In this area, the previous configuration of the network interface is displayed for information.
- The IP pool can be adjusted if necessary without leaving the extended configuration area.

Configuration table “General”

Parameters	Explanation	Configuration
IP address	Not changeable: IPv4 address of this network adapter	IPv4: e.g. 192.168.178.100
Subnet mask	Not changeable: Subnet mask of the network to which this network adapter is connected.	IPv4: e.g. 255.255.255.0
IP pool, start	First IP address of an IP address range (IPv4) that may be assigned within the network via DHCP.	IPv4: e.g. 192.168.178.150
IP pool, end	Last IP address of an IP address range (IPv4) that may be assigned by DHCP within the network.	IPv4: e.g. 192.168.178.200

Options

- In this area, the DHCP options can be configured.
- DHCP options can be changed, activated or deactivated.
- Default values for DHCP options can be restored with a mouse click in the event of a misconfiguration.

Important!

- The existing DHCP options are preconfigured for the proper operation of the end devices operated on the Access system. Additions and changes beyond the configuration options are only possible via the server operating system.

- If a separate DHCP server is used in the network, the network configuration (e.g. DHCP options) must be adjusted there for the Access system.
- Siedle hardware end devices (AFS/AFSV, AHTV/AHFV, AHT/AHF, AVP and ATLC) require an IP address and the following DHCP options from the DHCP server:

Configuration table "Options"

Function	Explanation	Procedure
Change option	Allows you to change the value of a DHCP option.	<ol style="list-style-type: none">1 Select entry in the listing.2 Change "Value".3 Execute "Apply" (tick symbol).
Restore default value	Allows you to restore the default value of a manually changed DHCP option.	<ol style="list-style-type: none">1 Select entry in the listing.2 Execute "Default value" (magic wand symbol).3 Execute "Apply" (tick symbol).
Activate/Deactivate option	Allows you to activate/deactivate a DHCP option.	<ol style="list-style-type: none">1 Select entry in the listing.2 Set/remove option from status "Activate option".3 Execute "Apply" (tick symbol).

DHCP options

DHCP option	Designation	Type	Value
4	Time Server	IP address	IP address of the Access Server
7	Log Server	IP address	IP address of the Access Server
42	NTP Server	IP address	IP address of the Access Server
66	Server Name	String	IP address of the Access Server

Note: Depending on the DHCP server, it may be necessary to put the IP address of option 66 in inverted commas above (e.g. "192.168.178.1").

Important!

If the DHCP option "150" is already used in the network, the value of the DHCP option "66" is overwritten/ignored (compliant behaviour according to RFC 5859).

67	Bootfile Name	String	SSS/Axxx/locator + IP address of the access server e.g.: SSS/Axxx/locator192_168_1_1.xml
----	---------------	--------	---

Note: Please pay attention to upper and lower case letters.

6 Setting up the Access system

Network settings (optional)

Leases

- In this area, all assigned IP addresses are displayed individually.
- Each IP address (temporarily) assigned to a device can be permanently reserved and edited for this device.
- In future, a reserved IP address will only be assigned to this device and is no longer available for other devices.
- Reservation is only possible within the IP address range (subnet) used and should be done outside the lease range.
- If a reserved IP address is no longer required, it is available again for all devices by releasing it.

Configuration table "Leases"

Function	Explanation	Procedure
Release	Releases a reserved IP address again.	1 Select entry in the listing. 2 Execute "Release".
Reserve	Reserves an IP address assigned to a device permanently for this device.	1 Select entry in the listing. 2 Execute "Reserve".

Reservations

- In this area, IP address reservations for devices can be configured manually.
- For an IP address reservation, the MAC address of the device and the IP address to be reserved must be known.
- Each manually assigned reservation can be deleted again at any time if required.
- Deleting a reservation is always possible in the "Reservations" menu and possible in the "Leases" menu if the reservation is within a lease range.

Configuration table "Reservations"

Function	Explanation	Procedure
New	Enables configuration of an IP address to be reserved.	1 Execute "New". 2 Enter "MAC address" and "IP address". 3 Execute "Apply" (tick symbol).
Delete	Deletes a manually configured reservation.	1 Select entry in the listing. 2 Execute "Delete".

6 Setting up the Access system

Licences

In this area, you can add new licences and see a licence overview. In addition, you can export the hardware ID needed for the licence order and import purchased licences.

Procedure – Licence order

- 1 Export the hardware ID (XML file).
- 2 Use the hardware ID to order the required Access licences (for a fee) from your Access Certified Partner (ACP) or distributor.

Important!

- For regular operation of Access Professional, an Access user licence must be purchased against a fee.
- The hardware identifier (XML file) generated by the Access system is required to order the license. The Access user licence and optional application licences are sold exclusively via ACPs.
- The demo period of an Access system without a valid access user license ends after 30 days. After the 30-day demo period has expired, the Access system deactivates and cannot be used until a valid Access user license has been imported.
- If you change significant parts of your hardware server or replace the entire hardware server, the hardware ID of the system can change and all previous licenses must be converted. Affected customers should contact their Access Contact or Access Certified Partner (ACP).
- For detailed information on the Access user and application licences, refer to the **Planning and System Manual Access Professional**.

Procedure – Importing new licences

- 1 Click on “Drop licence file here or click for selection”.
- 2 Navigate in your Windows Explorer to the storage location of the licence file.
- 3 Select the licence file.
- 4 Click on Open to start the licence import.
- 5 The licence file is displayed.
- 6 The new licences are imported and displayed in the listing in the “Licences” area.

User licences

• You need the Access user licences for normal operation of the Access system with the desired number of devices (e.g. door stations, indoor stations, access software clients, third-party devices (SIP phones)).

Application licences

• You need the Application licences for enabling operation of additional device types on the Access system (e.g. Access software clients, third-party devices (SIP phones)).

• Note: Software changes on the part of suppliers of third-party devices may limit the function / scope of functions of the third-party devices. Siedle cannot ensure permanent compatibility with third-party devices in every case.

Examples

An Access user licence for 10 devices can be used as follows:

- 9 Siedle hardware indoor stations and 1 door station or
- 5 Siedle hardware indoor stations, 1 door station and 4 optional software clients to be licensed (e.g. Access software in-house telephone on PCs).

An appropriate application licence must also be purchased for each optional hardware and software clients to be licensed (according to the example: 4 x ASHT 170-... – Access Software In-house telephone).

User licences

Licence type	Description
APR 670-0 B	Access Professional basic licence for activating and using Siedle Access Professional, Version 6 and above – user licence for 10 users (end devices) included.
APR 670-0 10	Access Professional user licence for extending and using Siedle Access Professional for up to 10 users (end devices).

Application licences

Licence type	Description
ALFA 270-0	Access application licence “Access licence for connecting a non-Siedle device” for the operation of a VoIP telephone (audio/video) on the Access Professional system. Using a VoIP-ATA adapter, it is also possible to connect an analog telephone. Third-party devices are subject to authorization by Siedle.
ALFC 270-0	Access application licence “Access licence for non-Siedle IP camera” for the operation of an IP camera on the Access Professional system. A licence is needed for each IP camera.
ALFM 270-0	Access application licence “Access licence function module” for extending the Access Professional system with additional useful system functions. The number of licences required depends on the function.
ALFP 270-0	Access application licence “Access licence for non-Siedle panel device” for the operation of a Jung touchscreen on the Access Professional system. A separate licence is required per device.
ALKNX 270-0	Access application licence “Access licence for KNX gateway” for the use of a KNX gateway on the Access Professional system. A separate licence is required per gateway.
ALSA 270-0	Access application licence “Access License for Siedle App” for the operation of a smartphone/tablet with Android/iOS on the Access Professional system. A license is required for each device with Siedle App installed.
ALT 270-0	Access application licence “Access licence for telephony connection” for the use of an external connection channel on the Access Professional system. A separate licence is required per channel. Third-party devices are subject to authorization by Siedle.
ASC 170-0 *	Access application licence “Access Software Concierge” for the operation of the ASC software on the Access Professional system. The ASC is the central communication interface at the reception. A separate licence is required per client.
ASHT 170-0 *	Access in-house telephone licence for connection of the software client in-house telephone to the Access system. A separate licence is required per client.

* Currently only PCs/laptops/tablets with Windows 10, 11

6 Setting up the Access system

Function modules

- In this area, you can add (import) new function modules for using additional system functions (such as digital video decoupling) and obtain an overview of all available functions in the Access Professional system.
- The Access system's standard functions are indicated as "Basic system" and added function modules as "Module" for the "Type".
- Whether the "ALFM 270-0" application licences are required or not for the standard operation of a function module depends on the function.
- To import a function module that requires a licence, the corresponding number of free application licences is required.
- An import without application licences is only possible during the 30-day demo period during initial commissioning.
- A function module is supplied as a file. It can be used immediately after import into the system.

Import function module

- 1** Click "Drop module file here or click for selection" in the "Module" area.
- 2** The file manager (Explorer) opens.
- 3** In the file manager, navigate to where the function module is saved in order to select it.
- 4** Click "Open" to confirm your selection.
- 5** The function module is imported and displayed in the "Active functions" list.

Available function modules

The portfolio of function modules grows in line with market requirements. Custom function modules are available upon request. A minimum system version of Access Professional may be required to use a function module. The selection of usable function modules therefore depends on the system version used. Function modules are only sold via Access Certified Partners (ACP). ACPs have access to all available function modules and the associated information via the Siedle Access service portal for ACPs (Access Wiki) at www.siedle.com

Configuration table "General"

Parameters	Explanation	Configuration
Active functions	List of all available functions in the Access Professional system.	<ul style="list-style-type: none">• Functions of type "Basic system" are part of the standard as-delivered status of the Access system and cannot be deleted.• Functions of type "Module" have been imported as function modules and can be deleted. <p>Functions Delete:</p> <ol style="list-style-type: none">1 Select entry in the listing.2 Execute "Delete".

Digital video decoupling

- This function module is subject to licence and enables use of the video streams of all cameras which are operated in the Access system via an ATLC... (Access system cameras and system-free analogue cameras via AIVS...) for professional video surveillance (e.g. for continuous video recording) or for other display systems (e.g. building automation panels, for displaying the video feed of a door call).
- The digital video decoupling of the Access system is like a video server for other systems and makes the available video streams of the enabled door cameras conveniently available for selection via ONVIF (one video stream per door camera).
- Once the function module has been imported, the new submenu item "Interfaces" is displayed in the navigation area under the "System maintenance" menu item. This is where the central activation and configuration for the digital video decoupling is carried out.
- If the video stream of one of the door cameras recognised in the Access system (system camera or system-free camera) is provided for digital video decoupling, then in the user area the "ONVIF camera enable" function must be activated and configured in the "Switching and controlling" area for the relevant door camera (door station with ATLC...).
- The video stream is transmitted on the door cameras (Access system cameras and system-free analogue cameras) in their native resolution.

Procedure

- 1** Import the "Digital video decoupling" function module into the Access system.
- 2** In the "System maintenance" > "Interfaces" menu, configure the "ONVIF camera enable" function and activate the "Enable door cameras via ONVIF" video option.
- 3** In the "User" > "Project"> "... " > [Door station with door camera] > "Switching and controlling" menu, activate the "ONVIF camera enable function" for each required door station and adjust the standard configuration if required.
- 4** Log in and configure the digital video decoupling for the Access system with the configured login data on the use system.
- 5** Checking the digital video decoupling.

Important!

- Configuration changes are only saved permanently with "Save".
- With every change made, the font colour of the page tab changes to red and "Save" is active.

Digital video decoupling – technical characteristics

Standard	ONVIF
ONVIF profile	S
Streaming protocol	RTSP
Video compression method	H.264
The transmitted resolution (pixels) of a video stream for each connected door camera	352 x 288 (CIF) – native resolution of system cameras or analogue system-free cameras

6 Setting up the Access system

Function modules

Activation of the function

The function is activated and configured in the "System maintenance" > "Interfaces" menu via the "ONVIF camera enable" function. The Access systems' digital video decoupling can only be used following authorisation (authentication with username and password).

Configuration table "ONVIF camera enable" (interfaces)

Parameters	Explanation	Configuration (last column)
Video	Option for activating or deactivating the ONVIF provision of all enabled door camera video streams.	
User name	Freely-selectable ONVIF username for authorised access to digital video decoupling on the Access system. The username can only be changed once the video option has been activated.	
Password	Freely-selectable ONVIF password for authorised access to digital video decoupling on the Access system. Always assign long, secure passwords (with upper and lower case, numbers and special characters)!	
Password, Repeat	Repeat password entry	

Selective video stream enabling

A video stream can be enabled for digital video decoupling for each door camera in the relevant camera menu under "Users" > "Project" > "... " > [Door station with door camera] > "Switching and controlling" > "ONVIF camera enable".

Configuration table "ONVIF camera enable" (configuration of the relevant camera)

Parameters	Explanation	Configuration (last column)
Profile name	Freely-configurable name for the door camera to differentiate the individual video streams when setting up and using digital video decoupling.	<ul style="list-style-type: none">• ON (green check): The video stream for this door camera is provided for use via the Access system's digital video decoupling.• OFF (red cross): Default presetting for each door camera (system camera and system-free camera). The door camera's video stream is not provided for use via the Access system's digital video decoupling.
Resolution	Displayed image size (e.g. 352 x 288) and compression method (e.g. H.264) of the video channel. Example: "352 x 288 (H.264)".	<ul style="list-style-type: none">• Information on non-assigned rights (yellow rights symbol): If no right(s) has/have been assigned yet for a function, then as of Access Professional 6.1.0, a yellow rights symbol appears next to the function in question.
RTSP	Door camera's video stream which, if use is enabled, is provided via the Access system's digital video decoupling via ONVIF.	

Call number plans

- With a call number plan you allow or forbid devices to dial certain call numbers.
- Each device is assigned a call number plan by the system.
- The “Standard” call number plan allows all call numbers to be dialed.
- The type of dialling (e.g. call via contact list, call by entry via number field or configured key) is not relevant for the call number plan.
- A call number plan consists of a call profile and the dialling rules it contains.
- Any number of profiles and dialling rules can be created.
- A dialling rule allows or forbids a call number or a range of call numbers.
- A forbidden dialling rule takes precedence over a allowed dialling rule.
- Dialling rules can be created individually by using a placeholder and must be saved after “Apply”.
- Individual call numbers can be entered in the numbering plan in order to explicitly allow or forbid them.
- External telephony is carried out with a configured prefix via the assigned telephony connection.
- The prefix must be a digit or digit sequence that is not used in the dialling rules for internal calls in the Access system.

Allowed characters

Character	Explanation	Allowed position
0...9	All digits from 0 to 9 are allowed	May be used alone or as a sequence of digits, as well as before the wildcard “*”
*	Wildcard for any number of digits	May be used alone or after one or more digits

Examples

- Several dialling rules can be used in combination in one call profile.
- With “*”, for example, all call numbers can be forbidden and then certain call numbers and call number ranges can be explicitly enabled (e.g. 110, 112, 911, 4*, 800*).

Dialling rules for internal calls

Dialling rule	Explanation
*	All numbers. If the dialling rule is allowed (“OK”), all call numbers can be dialed. Otherwise all call numbers are blocked.
4*	All call numbers beginning with “4” (e.g. “4156” or “487423”). If the dialling rule is allowed (“OK”), these numbers are allowed to be dialed. Otherwise, these numbers are blocked.

Dialling rules for external calls

Dialling rule	Explanation
99*	All call numbers with a prefix required for external telephony (e.g. 99* or 99004977237654321). If the dialling rule is allowed (“OK”), these numbers are allowed to be dialed. Otherwise these numbers are blocked.

6 Setting up the Access system

Permissions

- User rights in the Access System are arranged on the basis of folders.
- As of Access Professional 5.0.0, the project folder inherits all permissions to all subfolders, groups, time profiles, door stations, devices and directories located in it.
- The inheritance can be broken at any folder level.
- PABX gateways and SIP trunks are excluded from permission management.
- With the permission system, the Access system (see picture) controls which objects (“Who”) may access the functions (“Permissions”) of another object (“Target”) or are blocked for this.
- With folders, the permissions for all underlying objects can be configured centrally.
- If inheritance is continuous, permissions for all objects can be configured centrally in the “Project” folder.
- The permission structure can be broken up and individualized at any point.
- The permission configuration always affects the individual object.
- An object always has full permissions on its own functions.
- Permissions can only be configured if there are no unsaved changes on the device.
- If the permission icon is inactive, the configuration must first be saved in order to become active again.

Permission levels

Permission level	Effect
“Project” folder	The permission configuration affects globally the entire Access communication structure in case of continuous inheritance.
Subfolders	The permission configuration affects the objects in this folder in case of continuous inheritance.
Object	The permission configuration affects this single object.

Notes on the assignment of permissions

- In order to maintain clarity on the object level, only the additionally configured permissions are displayed.
- Each object always has access to its own switching points (switching contacts) and status points.
- It is not possible to block the own switching/status points.
- Switching contacts must always be enabled for other objects.
- Permissions for “Read” and “Execute” can be configured separately.
- “User status”, “Do Not Disturb”, “Call Redirection” and “Doormatic” can be enabled or disabled for other objects if required.
- If no additional right(s) has/have been assigned yet for a function, then as of Access Professional 6.1.0, a yellow rights symbol appears next to the function in question.
- If an object is moved in the folder structure using Drag&Drop, the assigned permissions are carried along.

Objects with permission configuration

Permissions can be configured for the following objects:

Object	Explanation
Folder	Configuration of the permissions of all objects in this folder
Groups	Configuration of the permissions of the group
Time profiles	Configuration of the permissions of the time profile
Door stations	Configuration of the permissions of the door station
Indoor devices	Configuration of the permissions of the indoor device (AFS/AFSV/AHF/AHFV/AHT/AHTV/AVP...)
External devices	Configuration of the permissions of the external device IP camera, SIP phone (Audio/Video), PABX phone, KNX gateway and JUNG panel (TKM client for Access)
Software client	Configuration of permissions for the ASC/ASHT clients and the Siedle App
Directory	Configuration of the permissions of the directory

No permissions can be configured for the following objects:

- PABX gateway
- SIP Trunk

Permission configuration

Option	Explanation
The "Read" option is set	Access to information by other objects (e.g. device A sees device B in its contact list)
The "Execute" option is set	Access to switching functions by other objects (e.g. device A may activate the switching contact of device B). The "Execute" option is only possible with the "Read" option activated!
"Inherited" option is set	Permissions for "Read" and "Execute" are automatically transferred, even in the case of subsequent changes

The following permissions are configurable (Read, Execute, Inherited)

- Directory
- User status
- Do not disturb
- Call redirection
- Switching points / Switching contacts
- Door light / Light
- Doormatic
- Door Opener / Door Opener 2
- Video surveillance
- Time profiles

Note

If no additional right(s) has/have been assigned yet for a function, then as of Access Professional 6.1.0, a yellow rights symbol appears next to the function in question.

6 Setting up the Access system

Folder

Folder

- Folders allow you to combine sub-folders, groups, time profiles, door stations, devices and directories in order to depict project circumstances comprising room-based, rights-based or organizationally-based groups (e.g. building with several companies or residential units – every company or residential unit is collated as a sub-folder and contains the relevant devices).
- Logical separations in the communication structure must be carried out using different folders and rights restrictions.
- Folders are to be regarded as organizational entities within the communication structure of the Access system.
- Folders are used for the logical clustering of objects, for mapping the desired Access system topology, and for the central administration of permissions.
- A folder inherits all set permissions if this inheritance has not been interrupted in the folder itself.
- Before you set up the folder structure, you should have defined the permissions of the respective folders.
- Once the folder structure has been set up, you create the objects and assign them to the folders using Drag&Drop.
- You can then continue with the details configuration of the individual objects.
- Do not configure any objects in the folder "Unconfigured devices".

Recommendation

Create a central folder for your project (e.g. building 1) in the Project folder, in which you map out the entire project structure.

Special features of the folders

Folder	Special feature
"Unconfigured Devices"	<ul style="list-style-type: none">• The Access system places all automatically detected Siedle Access devices in the "Unconfigured Devices" folder.• It serves as a collection point for all unassigned Siedle Access devices (e.g. newly connected devices) or deleted Siedle Access devices.• Siedle Access devices can be assigned to the "Project" folder or to another subfolder of the "Project" folder using Drag & Drop. <p>Exception: Manually created Siedle Access terminals are already located in the folder structure position in which you created them. The "Unconfigured Devices" folder cannot be configured, modified or deleted.</p>
"Project"	<p>The "Project" folder contains the entire configurable communication structure of the Access system:</p> <ul style="list-style-type: none">• Folder• Groups• Time profiles• Door stations• Indoor devices• External devices• Software clients• Directories• Administrator <p>The "Project" folder cannot be changed or deleted, but permissions can be changed centrally and inherited in the structure.</p>
Folder / Subfolders	<ul style="list-style-type: none">• Folders and their permissions inheritance can be configured, changed, moved or deleted within the communication structure of the "Project" folder.• The objects in the folder adopt these inherited permissions.• Access devices whose folders have been deleted are moved to the "Unconfigured devices" folder by the Access system. The device configuration is retained.• Access devices which are deleted from the "Unconfigured devices" folder lose their device configuration, only reappear in the "Unconfigured devices" folder after the device or system has been restarted, and are treated as a device that has been connected for the first time.

Important!

- Configuration changes are only saved permanently with "Save".
- With every change made, the font colour of the page tab changes to red and "Save" is active.

Configuration table "General"

Parameters	Explanation
Name	Name for the administration within the Access system (e.g. Main building). The name can be freely assigned and is displayed within the Access system administration (e.g. Display of the folder in the permissions management)
Description	Short description for your own understanding (e.g. All floors)

6 Setting up the Access system

Group

Tip!

Because the group is a call destination, we recommend that you create it before configuring the device, even if the group members can only be added at a later time. This allows the group to be configured as a call destination in the respective device.

- A group combines several devices in one call group and makes them accessible under one call number.

- A group can be reached via its own internal group call number and can be composed of any number of devices (e.g. All devices of the purchasing department).

- When the group call number is called, each assigned device is called at the same time.

- Several calls at the same time (behavior can be configured in the device configuration for "Allow Call Waiting"):

- If a group is called several times (e.g. door calls and internal calls), the first incoming call is displayed on the devices as the foreground call and subsequent calls as the background call (not with the Siedle App).

- If a device within the group accepts the first incoming call, the second remaining call is displayed on this device as a background call (depending on the device configuration).

- For the other devices in the group, the second call is then displayed in the foreground as an incoming call.

Important!

- Configuration changes are only saved permanently with "Save".

- Configuration changes that are confirmed with "Apply" must be saved with "Save".

- With every change made, the font colour of the page tab changes to red and "Save" is active.

- As long as no devices have been selected for the group and the selection has been saved, this is indicated by a yellow dot in the page tab and a yellow warning triangle in the header of the page.

Special features of the group

Special feature	Explanation
-----------------	-------------

Decentral video memories	Each device in the group has its own video memory. If the "Video memory" function of a door station is active, an image is stored in the video memories of all devices for which the automatic video memory is active when a door call is made to a call group. The door call image is stored on several video memories! The video memories of the devices are not synchronised within the group (e.g. deleting an image).
--------------------------	--

Decentral call lists	The door call image is stored on several video memories! The video memories of all devices are not synchronised within the group (e.g. deleting an image). Depending on the respective device configuration when "Allow Call Waiting" is selected, received calls to the other devices in the group are documented as "Missed Call" in the call list or are not entered.
----------------------	--

No central voicebox	The group itself does not have a central voicebox. The voicebox must be used by a device in the group.
---------------------	--

Configuration table "General"

Parameters	Explanation
Name	Name for administration within the Access system (e.g. All Departments). The name can be freely assigned and is automatically adopted by the "Show in contact list" function.
Description	Short description (e.g. Central call group departments). The description is displayed in the ASC software client.
Call number	Free extension, internally assigned call number (e.g. 121) suggested by the Access system. A call number can be changed at any time by observing the call number plan. Each call number must be unique in the entire Access system.
Reject a call	<ul style="list-style-type: none">• Option "Reject leads to the end of the group call" is set: If a device in the group rejects an incoming call, the pending call is terminated for all devices in the group.• Option is not set: If a device in the group rejects an incoming call, the incoming call is still pending on the other devices in the group until it is automatically terminated at the latest after the time specified by the system (max. ring duration).
Accepted calls	<ul style="list-style-type: none">• Option "Record as missed call for other users" is set: If a device in the group accepts an incoming call, this call is displayed as "Missed call" in the call list for all other devices in the group.• Option is not set: If a device in the group accepts an incoming call, this call is not displayed in the call list for all other devices.
Voicemail	<ul style="list-style-type: none">• The option "Allowed for group members while group call" is set: The voicebox of a device in the group takes over the pending call.Important: Only one voicebox may be active per group.• Option is not set: Group calls cannot be accepted by the voicebox of a device in the group.

Members

• In the "Members" area, all devices assigned to this group are displayed and you can add or remove additional devices to the group.

- As long as no devices have been selected for the group and the selection has been saved, this is indicated by a yellow dot in the page tab and a yellow warning triangle in the header of the page and on the dashboard.

Configuration table "Members"

Function	Explanation	Configuration
Add	Adding a member to the group	A mouse click on "Add" opens a selection list with selectable devices for this group. Select the desired device from the open list by clicking on it with the mouse. Each device must be selected individually. Important: If a call destination is not displayed, please check the permission settings.
Delete (dust bin symbol)	Removing a selected member from the group	Select the device in the "Members" list with a mouse click and then remove it with a mouse click on the dust bin symbol. Removed devices are immediately selectable again without caching with "Add".

6 Setting up the Access system

Group

Switching and controlling

- The configuration of these functions refers to this group.
- The functions can be activated or deactivated.
- The functions can only be configured when they are switched on.
- Depending on the function, the complete configuration of the function is not completed until it is assigned to a button/tile.

Note

If no additional right(s) has/have been assigned yet for a function, then as of Access Professional 6.1.0, a yellow rights symbol appears next to the function in question.

Configuration table "Switching and controlling"

Function	Explanation	Configuration
User status	Provision of this function for this group. Displayed name of the group (e.g. All Departments) in the contact list. The value is automatically taken over by "Name" from the "General" area and can be changed. The name can be freely assigned (e.g. Call group departments).	<ul style="list-style-type: none">• Label: Change of the displayed name in the system.• ON: The name is displayed in the contact list.• OFF: The name is not displayed in the contact list.
Do not disturb	Provision of this function for this group. If the function is active, no calls are signalled on the group for which this function was configured and the group is highlighted in red in the contact list.	<ul style="list-style-type: none">• Pen Icon (Label): Displayed name of the function (e.g. All Departments (Do Not Disturb)) in the Access system for configuration on other devices (e.g. for remote triggering)• ON: The function is active for this group• OFF: The function cannot be executed for this group
Call redirection	Provision of this function for this group.	<ul style="list-style-type: none">• Pen Icon (Label): Displayed name of the function (e.g. All Departments (Call Redirection)) in the Access system.• ON: The function is active for this group• OFF: The function cannot be executed for this group

Time profile

- With a time profile, switching points (e.g. a switching contact or the “Do Not Disturb” function) can be time-controlled.
- In 2 actions (On and Off), any number of switching points can be configured in the time profile in order to switch them on, off or over according to the time specification.
- The local time in the Access system is always used to execute the time profile.
- Any number of time profiles can be created.

Tip

With a time profile, several switching functions (e.g. switching Doormatic and call forwarding on/off) can also be executed at the same time via a button/tile or an input contact.

Important!

- Configuration changes are only saved permanently with “Save”.
- With every change made, the font colour of the page tab changes to red and “Save” is active.

Configuration table “General”

Parameters	Explanation
Name	Name for the administration within the Access system (e.g. Entrance area). The name can be freely assigned and is displayed within the Access system administration.
Description	Short description (e.g. Opening times for the main entrance)
Label (Status)	Displayed name as switching point in the system (e.g. Main entrance (manual)) to execute an action manually. A manually executed action remains until it is changed by the automatic of the time profile, if necessary. Please assign meaningful names to avoid confusion during configuration.
Label (Automatic mode)	Displayed name as switching point in the system (e.g. Main entrance (automatic)) to switch the time profile automatic on and off. If the time profile automation is switched off, the actions remain in the status they were last in until the time profile automation is switched on again or a manual intervention is made in another way (e.g. via “Label (Status)”). The name can be freely assigned. Please use meaningful names to avoid confusion during configuration.

Note

If no additional right(s) has/have been assigned yet for a function, then as of Access Professional 6.1.0, a yellow rights symbol appears next to the function in question.

6 Setting up the Access system

Time profile

Time profile

- In the "Time Profile" area, the switching times for the respective action to be executed are configured:
 - At the beginning of a configured time period, the "Actions for On" are executed.
 - At the end of a configured time period, the "Actions for Off" are executed.
- In automatic mode, the respective action is executed automatically according to the timings.
- With each start of a time period the "Actions for On" takes place and with each end of a time period the "Actions for Off" takes place.

Configure times in weekly schedule (timeline)

- The display in the weekly schedule is daily with a configurable period from "0" to "24" o'clock. Several periods can be configured for each day in the weekly schedule.
- The times in the weekly schedule can be configured daily (per time-lime) by mouse operation (click & hold):
 - Optically, the smallest time unit in the timeline is 15 minutes.
 - An entry to the minute is possible in the 2nd step with the right mouse button: Right click on a configured time period and an window appears for the entry to the minute (Start and Stop).
- If there is no visual interruption between two time periods in the time bar, the system will treat this as one time period, even if the configuration is accurate to the minute and there is an interruption between the two time periods.

Configure actions for "On" and "Off"

- Within the time profile, the various switching points can be assigned to an action:
 - "Actions on On": At the beginning of a time period configured in the weekly schedule, switching points stored here are switched on, off or toggled.
 - "Actions for Off": At the end of a time period configured in the weekly schedule, switching points stored here are switched on, off or toggled.
- To keep the overview we recommend (if possible) to store switching points that are to be switched on in "Actions for On" and switching points that are to be switched off in "Actions for Off".
- On the system side, however, all switching states (switch on, switch off or toggle) can be configured.

Available switching points in Actions for "On" and "Off"

- The Actions for "On" and "Off" are independently configurable from each other.
- Each time profile can switch several switching points simultaneously:
- No function
 - Trigger "Storey Call" on another device, with associated door opener and door light contact
 - Switching "Send KNX Telegram" on, off or toggle
 - Switching "Do Not Disturb" on, off or toggle
 - Switching "Call Redirection" (Immediately, Time or Redirect if busy) on, off or toggle
 - Switching Switch Point on, off or toggle
 - Switching "Doormatic" on, off or toggle

Configuration table "Actions for On/Off"

Function	Explanation	Configuration
No function	-	-
Storey call	Call signalling which is output on a device or a group of devices when triggered. A storey call is signalled for approx. 5 seconds.	Important: If this function of another device is not displayed, please check the permission settings. <ul style="list-style-type: none"> • Call destination: Select the device or group on which this function is to be executed. • Door opener: Selection of the door opener contact that can be switched by the device. • Door light: Selection of the door light contact that can be switched by the device
Send KNX telegram	A KNX telegram is sent from a device (configured KNX gateway required). Important: The effect of the KNX telegrams in the KNX system depends on the configuration of the KNX system.	<ul style="list-style-type: none"> • Gateway: Selection of the KNX gateway • Group address: Address of a KNX device that is to receive the KNX telegram • Feedback object: Address via which the status of a KNX device is to be reported back • Value (type of execution): <ul style="list-style-type: none"> - Toggle (change of function state: (ON becomes OFF / OFF becomes ON) - On (function is activated) - Off (function is deactivated)

6 Setting up the Access system

Time profile

Configuration table "Actions for On/Off"

Function	Explanation	Configuration
Do not disturb	No calls are signalled on a device and the device is marked red in the contact list. Callers receive a busy signal.	<p>Important: If this function of another device is not displayed, please check the permission settings.</p> <ul style="list-style-type: none">• Do not disturb: Selection of the device or the group at which this function is to be activated• Value (type of execution):<ul style="list-style-type: none">- Toggle (change of function state: (ON becomes OFF / OFF becomes ON)- On (function is activated)- Off (function is deactivated) <p>Recommendation: In addition, an status display should be configured for this function.</p>
Call redirection	Incoming calls are redirected to another call destination on a device on which call redirection is active.	<p>Important: If this function of another device is not displayed, please check the permission settings.</p> <ul style="list-style-type: none">• Redirect: Selection of the device on which this function is to be executed.• Destination: Device or group to which the call is redirected.• Type (configuration of call redirection):<ul style="list-style-type: none">- Immediately (all calls are redirected immediately)- After time with the option "Immediately if busy" (all calls are redirected with time delay; calls on busy are redirected immediately)- Redirect if busy (only calls on busy are redirected). <p>Recommendation: In addition, an status display should be configured for this function.</p>
Switching	A switching function is triggered on a device.	<p>Important: If this function of another device is not displayed, please check the permission settings.</p> <ul style="list-style-type: none">• Switching point: Selection of a device switching contact for this function• Value (type of execution):<ul style="list-style-type: none">- Toggle (change of function state: (ON becomes OFF / OFF becomes ON)- On (configured switching point is switched on)- Off (configured switching point is switched off) <p>Recommendation: In addition, an status display should be configured for this function.</p>

Configuration table "Actions for On/Off"

Function	Explanation	Configuration
Doormatic	If the Doormatic function is activated, a door opener is automatically triggered according to the configuration when a door call is made.	<p>Important: The function must first be switched on and configured in the "Switching and controlling" area of the device (device-related Doormatic) or the door station (door-related Doormatic). If this function of another device is not displayed, please check the permission settings.</p> <ul style="list-style-type: none">• Doormatic: Selection of the device on which this function is to be executed• Value (type of execution):<ul style="list-style-type: none">- Toggle (change of function state: (ON becomes OFF / OFF becomes ON)- On (function is activated)- Off (function is deactivated) <p>Recommendation: In addition, an status display should be configured for this function.</p> <hr/>

6 Setting up the Access system

Directory

Directory

- The directory contains individually created contacts (e.g. external call destinations).
- Any number of directories can be created in the Access system.
- Each device can be assigned an directory by the system.
- The directory adds additional entries to the existing system entries in the contact list of the devices.
- All contacts can be called directly via the directory (contact list) of the devices of the Access system.
- All entered call destinations must be released in the call number plan.

Important!

- Configuration changes are only saved permanently with "Save".
- With every change made, the font colour of the page tab changes to red and "Save" is active.

Configuration table "General"

Parameters	Explanation
Name	Name for the administration within the Access system (e.g. Directory). The name can be freely assigned and is displayed within the Access system administration (e.g. assignment of an directory in the device configuration)
Description	Short description (e.g. Public directory)

In the Directory area, all directory entries (contacts) created in this directory are displayed and you create or remove additional directory entries.

Configuration table "Directory"

Function	Explanation	Configuration
New	Create new entry	Click on "New": A new window opens in which you can create a contact. Each contact can be entered the following information: Name, phone number and comment.
Edit	Edit selected entry	Select entry in the "Directory" list with a mouse click. Click on "Edit" with the mouse: A window opens in which you can edit the informations for this contact.
Delete (dust bin symbol)	Remove selected entry	Mark the entry in the "Directory" list with a mouse click and then remove it with a mouse click on the dust bin symbol.

7 Configure devices

Device types and recommended configuration order

Door stations

A door station is located at an access or passageway of a property which has a door (e.g. door station at the entrance door). Every door station requires an Access door loudspeaker controller (ATLC) which is automatically recognized by the Access server.

Indoor devices / Software clients

Hardware or software device which can be used by the end user.

External devices

External devices contain hardware or software end devices as well as central interfaces (gateways) to KNX or telephony systems that can be used by the end user.

Recommended configuration order

Because the SIP trunk, the PABX and KNX gateway connects the Access system with other systems and can provide central functions, these external devices should be configured first:

- 1 SIP trunk, PABX and KNX gateway
- 2 IP cameras
- 3 Indoor devices
- 4 SIP phone, PABX phone (external devices)
- 5 Software clients
- 6 Door stations

Device type	Model	Description
Door station	Access door loudspeaker controller (Siedle ATLC 670-...)	Hardware switch panel device for linking a door station to the Access server.
Indoor device	Access ... handsfree telephone (Siedle AFS/AHF 870-...)	Hardware terminal: Audio indoor station for wall or table-top operation.
	Access in-house telephone (Siedle AHT 870-...)	Hardware terminal: Audio indoor station for wall operation.
	Access ... video handsfree telephone (Siedle AFSV/AHFV 870-...)	Hardware terminal: Video indoor station for wall or table-top operation.
	Access video in-house telephone (Siedle AHTV 870-...)	Hardware terminal: Video indoor station for wall operation.
	Access video panel (Siedle AVP 870-...)	Hardware terminal: Touch panel-based video indoor station for wall or table-top operation.
External device	IP camera	Hardware end device: Network camera for use by other devices in the Access system.
	JUNG Panel	Software client: Software video indoor station for operation on a JUNG touch panel (JUNG Smart Control 8, JUNG KNX Smart Panel 8).
	SIP telephone	SIP telephone linked over the network at the Access server.
	PABX gateway	IP-based telephony connection for a speech channel between Access system and VoIP telephone system (SIP) or SIP account of other systems.
	PABX phone	Telephone that is operated directly on a telephone system. A SIP connection (PABX gateway or SIP trunk) must be possible for the connection to the Access system.
	SIP Trunk	IP-based telephony connection for one or more speech channels between Access system and truncated VoIP telephone system (SIP).
	KNX Gateway	Interface for the IP-based connection of a KNX building automation solution with the Access system.

7 Configure devices

Device types and recommended configuration order

Device type	Model	Description
Software client	Access Software Concierge (Siedle ASC 170-...)	Software client: Central door management system and video indoor station for operation on any optional Windows-based computer.
	Access Software In-house telephone (Siedle ASHT 170-...)	Software client: Video indoor station for operation on any optional Windows-based mobile or stationary operated computer.
	Siedle App	The Siedle app turns a smartphone/tablet (iOS, Android) into a mobile extension of a door intercom system from Siedle, via the Siedle server.

SIP Trunk

SIP Trunk

- A SIP trunk enables the connection of the Access system with a SIP-enabled remote station (e.g. telephone system) with a SIP voice channel (connection) or several (bundled) SIP voice channels (connections) via an IP-based network.
- Configuration parameters are partly given by the remote station.
- The systems are connected exclusively via the static IP address without user name and password.
- Prefixes for the SIP trunk and, if necessary, entire call numbers or call number blocks must be considered in the call number plan.
- The connection status of the SIP trunk is not displayed in the "User Status" menu.

Notes on prefix

- A prefix must be assigned for external dialing into another telephony network.
- Each external call must be preceded by the dialling prefix.
- Structure of the call number: [Dial prefix][if applicable, complete number area code for continent/ count/city] [Call number of the line in the public telephone network]
- The prefix should be a digit or sequence of digits that is not used for internal calls in the Access system.
- The existing number ranges and prefixes must not overlap.
- Overlaps are indicated by a yellow warning triangle after saving.

Important!

- Configuration changes are only saved permanently with "Save".
- With every change made, the font colour of the page tab changes to red and "Save" is active.

7 Configure devices

SIP Trunk

Configuration table “General” and “SIP Trunk”

Parameters	Explanation	Configuration
Name	Name for the administration within the Access system (e.g. External telephony). The name can be freely assigned and is displayed within the Access system administration (e.g. assignment of a SIP trunk in the device configuration of a PABX phone)	–
Description	Short description (e.g. Connection to the central SIP telephone system) for your own information.	–
Device type	Non-changeable information field that contains the device type.	–
Prefix	System internal prefix with one digit (e.g. “0”) or several digits (e.g. “00”) to initiate a call outside the Access system (e.g. Dialing into the network of the local telephone system from the Access system).	e.g. “0” or “00”
Remote prefix	External prefix with one digit (e.g. “9”) or several digits (e.g. “99”) to mark the call origin from the Access system for the provision of further telephony features (e.g. Callback via SIP trunk) of the remote station. The digits 0-9 and the characters * and # can be used.	e.g. “9” or “99”
Lines	Maximum number of available SIP voice channels which can be operated in parallel. Each voice channel requires an ALT 270-... license. The maximum value is specified by the remote station (e.g. telephone system).	e.g. “10”
Door release (DTMF)	The door release function can be triggered via the configured DTMF coding (e.g. “#61”) of the multi-frequency dialling method. System-side preconfigured is “#61”. The digits 0-9 and the characters * and # can be used.	e.g. “#61”
Door light (DTMF)	The door light function can be triggered via the configured DTMF coding (e.g. “#50”) of the multi-frequency dialling method. System-side preconfigured is “#50”. The digits 0-9 and the characters * and # can be used.	e.g. “#50”
Allow DTMF only for calls from door to the gateway	If this option is set, the door opener and door light function can only be triggered via DTMF coding via a telephone if the telephone has been called by a door call. If this option is not set, the door opener and door light function can be triggered via DTMF coding both for an incoming door call (door calls phone) and for a direct door call (phone calls door).	–
IP address	IPv4 address of the remote station.	e.g. “192.168.178.100”
Frame size	Length of the audio content of the RTP data packets (audio frames) to be transmitted in milliseconds. The adjustable values are 20ms and 40ms. Only the audio codec G.711 a-law or μ -law is used. <ul style="list-style-type: none">• Auto: Outgoing calls are set by the Access system with the frame size “40ms”. For incoming calls, the Access system provides the preset frame size of the remote terminal (“20ms” or “40ms”).• 20ms: The value for the frame size is fixed at 20ms.• 40ms: The value for the frame size is fixed at 40ms.	e.g. “Auto”

Configuration table “General” and “SIP Trunk”

Parameters	Explanation	Configuration
Port	Configurable port for negotiating the SIP communication parameters of the SIP trunk. The selected port must also be configured in the remote station. Possible input range: 1-65535.	e.g. “5060”

7 Configure devices

PABX gateway

PABX gateway

- A PABX gateway enables the connection of the Access system with a SIP-enabled remote station (e.g. telephone system, VoIP connection) with a SIP voice channel (connection) via an IP-based network.
- Configuration parameters are partly given by the remote station.
- The systems are connected in the same way as a SIP user account with given login data.
- Prefixes for the PABX gateway and, if necessary, entire call numbers or call number blocks must be considered in the call number plan.
- The connection status of the PABX gateway is displayed in the "User Status" menu.

Notes on prefix

- A prefix must be assigned for external dialing into another telephony network.
- Each external call must be preceded by the dialling prefix.
- Structure of the call number: [Dial prefix][if applicable, complete number area code for continent/count/city] [Call number of the line in the public telephone network]
- The prefix should be a digit or sequence of digits that is not used for internal calls in the Access system.
- The existing number ranges and prefixes must not overlap.
- Overlaps are indicated by a yellow warning triangle after saving.

Important!

- Configuration changes are only saved permanently with "Save".
- With every change made, the font colour of the page tab changes to red and "Save" is active.

Configuration table "General"

Parameters	Explanation	Configuration
Name	Name for the administration within the Access system (e.g. External telephony). The name can be freely assigned and is displayed within the Access system administration (e.g. Assignment of a PABX gateway in the device configuration of a PABX phone)	–
Description	Short description (e.g. Connection to the external VoIP connection) for your own information.	–
Device type	Non-changeable information field that contains the device type.	–
Prefix	System internal prefix with one digit (e.g. "0") or several digits (e.g. "00") to initiate a call outside the Access system (e.g. Dialing into the network of the local telephone system from the Access system).	e.g. "0" or "00"
Calls (incoming)	System-side handling of incoming calls from the remote station. <ul style="list-style-type: none">• Reject: Incoming (external) calls from the remote station are always rejected.• Redirect to...: Incoming (external) calls from the remote station are always immediately redirected to the selected device or to the selected group.	e.g. "Reject"
Door release (DTMF)	The door release function can be triggered via the configured DTMF coding (e.g. "#61") of the multi-frequency dialling method. System-side preconfigured is "#61". The digits 0-9 and the characters * and # can be used.	e.g. "#61"
Door light (DTMF)	The door light function can be triggered via the configured DTMF coding (e.g. "#50") of the multi-frequency dialling method. System-side preconfigured is "#50". The digits 0-9 and the characters * and # can be used.	e.g. "#50"
Allow DTMF only for calls from door to the gateway	If this option is set, the door opener and door light function can only be triggered via DTMF coding via a telephone if the telephone has been called by a door call. If this option is not set, the door opener and door light function can be triggered via DTMF coding both for an incoming door call (door calls phone) and for a direct door call (phone calls door).	

7 Configure devices

PABX gateway

Configuration table "PABX Gateway"

Parameters	Explanation	Configuration
Registrar	IPv4 address or DNS name of the remote station (e.g. IPv4: 192.168.178.100 or DNS names: voipgate.de).	e.g. "192.168.178.100"
Account	Default SIP user name (SIP ID, SIP account name or phone number) of the SIP user account.	e.g. [Call number incl. complete area code]
Password	Given password for the SIP user account	[Password]
Password, repetition	Repeat password entry	[Password]
Frame size	Length of the audio content of the RTP data packets (audio frames) to be transmitted in milliseconds. The adjustable values are 20ms and 40ms. Only the audio codec G.711 a-law or μ -law is used. <ul style="list-style-type: none">• Auto: Outgoing calls are set by the Access system with the frame size "40ms". For incoming calls, the Access system provides the preset frame size of the remote terminal ("20ms" or "40ms").• 20ms: The value for the frame size is fixed at 20ms.• 40ms: The value for the frame size is fixed at 40ms.	e.g. "Auto"
Transport	Configurable protocol for negotiating the SIP communication parameters of the PABX connection via UDP, TCP or TLS (TCP over TLS). The selected protocol must also be configured in the remote station. Please note the respective standard ports of the protocols.	e.g. "UDP"
Port	Configurable port for negotiating the SIP communication parameters of the PABX connection. The selected port must also be configured in the remote station. Possible input range: 1-65535. Standard ports of the protocols: <ul style="list-style-type: none">• UDP/TCP: 5060 - Session Initiation Protocol (SIP)• TLS: 5061 - Session Initiation Protocol (SIP) over TLS	e.g. "5060" for UDP/TCP and "5061" for TLS

KNX Gateway

KNX Gateway

- A KNX gateway enables the Access system to be connected to a KNX building automation system via an IP-based network, to be able to trigger KNX functions via devices of the Access system.
- A licence (ALKNX 270-...) is required for each KNX gateway that is to be connected to the Access system.
- Configuration parameters (IP Address, Port, KNX addresses) are given by the configured KNX system.
- Permissions for device access to the KNX switching points must be given in the Access system.
- The connection status of the KNX gateway is displayed in the "User status" menu.

Important!

- Configuration changes are only saved permanently with "Save".
- With every change made, the font colour of the page tab changes to red and "Save" is active.
- A missing IP address or missing permissions are indicated by a yellow dot in the page tab and a yellow warning triangle in the header of the page.

Configuration table "General"

Parameters	Explanation	Configuration
Name	Name for the administration within the Access system (e.g. KNX gateway building 10). The name can be freely assigned and is displayed within the Access system administration (e.g. Connection status of the KNX gateway in the subscriber status menu)	–
Description	Short description (e.g. Central building automation) for your own information.	–
Device type	Non-changeable information field that contains the device type.	–
IP address	IPv4 address of the KNX gateway	e.g. "192.168.178.100"
Port	Network port of the network connection between the Access system and the KNX system. The port is given by the configured KNX system. System-side preconfigured is port 3671. Please note that this port may have to be considered in the firewall configuration of the network.	e.g. "3671"

7 Configure devices

KNX Gateway

KNX group addresses

(switching points)

- In the "KNX" area you can add, edit or delete KNX group addresses.
- All added KNX group addresses are displayed here.
- The configuration parameters (e.g. Group Address, Feedback Object) are given by the configured KNX system.

Configuration table "KNX"

Function	Explanation	Configuration
New	Add a new KNX group address.	Click on "New": A new window opens in which you can create a KNX group address. For each KNX group address the following information can be entered: Label (designation), Group address (e.g. 10/1/10) and Feedback object (e.g. 10/1/15).
Edit	Edit selected KNX group address.	Select the KNX group address in the "Group addresses" list with a mouse click. Click on "Edit" with the mouse: A window opens in which you can edit the information for this KNX group address.
Delete (dust bin symbol)	Remove selected KNX group address.	Select the KNX group address in the "Group addresses" list with a mouse click and then remove it with a mouse click on the dust bin symbol (Delete).

IP camera

IP camera

- As of Access-Professional 7.0, IP cameras with the ONVIF standard, Profile "S" and video compression method H.264 can be used.
- The available performance features depend on the Access system version.
- Individual performance features may only be possible on certain types of end device (e.g. advanced concierge video functions on the ASC 170-0 software client).
- A licence (ALFC 270-...) is required for each IP camera which is to be connected to the Access system.
- The configuration parameters (e.g. IP address, ONVIF port, authorisation, ONVIF profile) are specified by the IP camera.
- The readiness for operation/connection status of the IP camera is shown in the "User status" menu.

The following performance features are available with system version 7.0:

- Advanced Concierge video functions (for client software ASC...): Additional video functionality for the Concierge software at the reception. For more information, see page 84
- Camera observation (for video indoor call stations AHTV..., AHFV..., AVP... as well as client software ASC... and ASHT...): Manual camera selection from available IP cameras.
- Camera scan (for client software ASC...): Automatic camera selection from available IP cameras.

Important!

- Configuration changes are only saved permanently with "Save".
- With every change made, the font colour of the page tab changes to red and "Save" is active.
- A missing IP address or missing permissions are indicated by a yellow dot in the page tab and a yellow warning triangle in the header of the page.

7 Configure devices

IP camera

Access system limits (IP cameras)	Access Professional	ASH 671-0 M	ASH 671-0 S
Possible number of simultaneously usable video streams (from different IP cameras)	When fulfilling the requirements for on-site systems: such as with ASH 671-0 M or S.	10	1
Recommended resolution of an IP camera video stream (pixels)	max. 640 x 480 (VGA)		
Recommended frame rate of an IP camera video stream	15 Frames/second (fps)		
Transferred resolution for connected end devices (pixels)	352 x 288 (CIF)		

Configuration table "General"

Parameters	Explanation	Configuration
Name	Name for the administration within the Access system (e.g. IP camera 1). The name can be freely assigned and is displayed within the Access system administration (e.g. assignment of an IP camera in the device configuration).	–
Description	Short description for your own information (e.g. IP camera outdoor area). The description is displayed in the software client.	–
Device type	Non-changeable information field that contains the device type.	–
IP address	Ipv4 address of the IP camera. To the right of the input field for the IP address, you will find the device search (button with magnifying glass symbol). The device search can be used to select a camera from a list of all the IP cameras detected in the Access network.	e.g. "192.168.178.200"
Port	Port for the network connection for the ONVIF communication between IP camera and Access system. The port is specified by the IP camera. Please note that this port may need to be taken into account in the network's firewall configuration.	e.g. "443"
User name	Preset ONVIF username for the IP camera user account.	[User name]
Password	Preset ONVIF password for the IP camera user account.	[Password]
Repeat	Repeat password entry	[Password]

Camera information

In this area, all the ONVIF profiles of the video stream provided by an IP camera and identified by the Access system are displayed along with resolution and compression method. For each ONVIF profile, use in the

Access system can be selectively permitted or prohibited.

Configuration table "Camera information"

Parameters	Explanation	Configuration (last column)
Name	Name of the ONVIF profile which is provided in the network by a video source (e.g. ONVIF network camera). The displayed name is specified by the video source.	<ul style="list-style-type: none">• ON (green check): The video channel can be used in the Access system.• OFF (red cross): The video channel has been manually deactivated and cannot be used in the Access system.• OFF (grey cross): The video channel has been deactivated by the system (e.g. because the video formats or video resolutions cannot be used).
Resolution	Displayed image size (e.g. 352 x 288) and compression method (e.g. H.264) of the video channel. Example: "352 x 288 (H.264)".	

Switching and controlling

- The configuration of these functions refers to this device.
- The functions can be activated or deactivated.
- The functions can only be configured when they are switched on.

Note

If no additional right(s) has/have been assigned yet for a function, then as of Access Professional 6.1.0, a yellow rights symbol appears next to the function in question.

Configuration table "Switching and controlling"

Function	Explanation	Configuration
Video memory	Provision of this function on this device.	Mode: <ul style="list-style-type: none">• Record images manually only: Manually recorded image is stored in the video memory.• ON: The video memory is active for this device.• OFF: The video memory is not used.
Video surveillance	Provision of this function on this device. If the function is active, the camera observation of this device can be configured on another device for usage. With Access system version 7.0.0, the IP camera observation of available IP cameras can be used for the video indoor call stations AHTV..., AHFV..., AVP... with manual camera selection, as well as for the client software ASC... and ASHT... with automatic camera selection.	<ul style="list-style-type: none">• Label: Change to the displayed name (e.g. outdoors video surveillance) in the Access system for configuration on other devices.• ON: The function is active for this device• OFF: The function cannot be executed for this device.

7 Configure devices

Indoor devices

Indoor devices

Indoor device AFS/AHF... (Access standard handsfree telephone / Access handsfree telephone)	The AFS/AHF... is an audio indoor device from Siedle with hands-free functionality.
Indoor device AFSV/ AHFV... (Access standard video handsfree telephone / Access video handsfree telephone)	The AFSV/AHFV... is an indoor video device from Siedle with hands-free functionality.
Indoor device AHT... (Access in-house telephone)	The AHT is an audio indoor device from Siedle with handset functionality.
Indoor device AHTV... (Access video in-house telephone)	The AHTV is an indoor video device from Siedle with handset functionality.
Indoor device AVP... (Access video panel)	The AVP is an indoor video device from Siedle with touchscreen and hands-free functionality. The AVP has a flat surface-mounted housing for wall and table mounting. Table mounting requires a table accessory.

Inputs/Outputs (AFS...)

- The device is equipped with 1 switching input. An extension is not possible.

Inputs/Outputs (AH.../AVP...)

- The device is equipped with 1 switching input and 1 switching output.
- Optionally, it can be extended with the "Access input/output accessory AZIO 870-0" by 1 switching input and 1 switching output each.

Background calls / several simultaneous calls:

Up to 10 calls can be pending and a maximum of one foreground and one background call can be displayed simultaneously. The first incoming call is displayed in the foreground, all subsequent incoming calls are classified as background calls and prioritised (first all door calls, then the other calls). The calls can be processed in the specified order.

Important!

- For configuration, the device must be in the communication structure "Project".
 - A complete configuration in the "Unconfigured devices" folder is not possible because devices in this folder do not have any permissions.
 - Configuration changes are only saved permanently with "Save".
 - Configuration changes that are confirmed with "Apply" must be saved with "Save".
 - With every change made, the font colour of the page tab changes to red and "Save" is active.
 - With saved changes that require a device restart, a yellow dot in the page tab and a yellow warning triangle in the header of the page indicate that the device must be restarted.
 - A device restart is possible on the same page or via the dashboard.
- If this device is deleted within the communication structure, it is moved to the "Unconfigured devices" folder.
 - If this device is deleted from the "Unconfigured Devices" folder, it will be removed from the communication structure.
 - However, if this device is still connected to the Access system, it will reappear in the "Unconfigured Devices" folder after the Access system is restarted.
 - By clicking on "Lists" in the header area, all contacts, cameras (only for video indoor units) and switching contacts (switching list) available on this device are displayed.

Configuration table "General"

Parameters	Explanation
Name	Name for administration within the Access system (e.g. Apartment 01 - Floor 1). The name can be freely assigned and is automatically adopted by the "Show in contact list" function.
Description	Short description (e.g. private indoor device). The description is displayed in the software client.
Device type	Non-changeable information field that contains the device type.
Call number	Free extension, internally assigned call number (e.g. 121) suggested by the Access system. A call number can be changed at any time by observing the call number plan. Each call number must be unique in the entire Access system.
MAC address	Unique hardware address of the device. The MAC address is automatically entered for each device detected by the system. Each MAC address is unique in the entire Access system. For manually created devices, this field must be filled manually with the MAC address of the device (Format: XX:XX...XX; e.g. D4:E3:2C:00:03:2F). Tip: If, for example, you need to replace this device due to a service case, save the new MAC address in this mask before replacing it. This causes the new device to adopt the existing configuration and you do not have to completely reconfigure it.
Directory (AHF.../AHT.../ AVP... only)	Assigned directory. Optionally, an individually created directory can also be assigned.
Call profile	With the call profile you allow or forbid the device certain call or phone numbers. On the system side, no restrictions are preconfigured in the default state of the call profile.
Installation type (AFS.../AHF... only)	Depending on the mounting method (wall or table-top operation), the microphone behaviour changes (echo cancelling). When operating at a table, echo can be generated if the wrong type of mounting is selected, because reflections from the table top can cause feedback at the loudspeaker. If you do not know the mounting method at the time of commissioning, select the "Table" mounting method.
Ringtone volume	Volume of call signalling, adjustable from 1 to 5 (1 to 6 for AFS/AFSV...). The setting value 1 complies with a minimum audible volume and can be increased step by step. Muting is possible on the end device via the key assignment "Ringer off".
Speech volume	Speech output volume, adjustable from 1 to 5 (1 to 6 for AFS/AFSV...). The setting value 1 complies with a minimum audible volume and can be increased step by step. The speech volume can also be adjusted via the end device.
Time (AHF.../AHT.../ AVP... only)	Option whether or not to display the time on the indoor device. Recommendation: If you operate an Access system across multiple time zones, this option should be disabled.
Call waiting	<ul style="list-style-type: none">• Option "Transferring calls even during an active call" is not set: When calling a device with an existing connection, the caller receives a busy signal. Background calls are not displayed or signalled.• Option "Transferring calls even during an active call" is set: If a connection is established, further calls are visually output on the called device and can be processed one after the other.• Multiple simultaneous calls (max. 10 calls): A maximum of one foreground call and one background call can be shown on the display at the same time. More calls are queued in the background and can be processed in the specified order.
Ringtones	Option for changing the standard ring tones for door calls, storey calls and standard calls (internal/external calls) on this device.

7 Configure devices

Indoor devices

Button configuration (AFS/AFSV... only)

The function of a button can be configured for the “Single click” operating mode:

- Single Click: If a button is pressed and released again, a function is triggered.

Button configuration (AHF/AHT/AHFV/AHTV... only)

The functions of a button can be configured either for the “Single/Double click” or “Press/Release button” operating modes:

- Single Click: If a button is pressed and released again, a function is triggered.
- Double Click: If a button is pressed and released twice in quick succession, a function is triggered.
- Press button: If a button is pressed, a function is triggered.
- Release button: If a button that has already been pressed is released again, a function is triggered.
- If the operating mode (e.g. Double

Click) of a button is changed, the configured function of the button is lost.

Button configuration (AVP... only)

- The door opener key and up to 44 tiles can be configured.
- Each key/tile can be assigned one function.
- The name of the “Door release button” cannot be changed.
- The name and icons of the tiles can be assigned individually.
- Each tile features an optical feedback signal (e.g. Active signal due to a colour-changing tile when the function is switched on).
- There are different icons (e.g. light, group call,...) to choose from.
- Each function features a pre-configured icon and label.
- Each tile can be placed at any position of the three possible display pages via the display on the device.

































Inputs

Each input can be configured for a function that is to be triggered when the input is actively switched or closed.

Tip

- With a time profile, several switching functions (e.g. switching Doormatic and call forwarding on/off) can also be executed at the same time via a button/tile or an input contact.
- If this function is not displayed, please check the permission settings.

Use of symbols (AVP... only)

 Image view	 Design	 Contact list (personal address book)
 Status display	 Display, Display	 Door light, switch light, switch door light
 Language	 Cleaning the display	 Microphone muting, Microphone off
 System information	 ECO mode	 Mail notification system, letterbox notification system
 Door	 ECO mode	 Reset
 Door release, release door, trigger the door release	 Settings	 Ringtone muting, Ring tone off
 Video memory	 House, Building, Home,	 Call rerouting, reroute calls
 DND (Do not disturb)	 Cameras / Door station	 Delayed call rerouting, reroute calls with delay
 Calls list	 Contact (External), All contacts, External call	 All switching functions, Switching, switch
 Audio	 Contact (Group), Group call, Call group	 Switching, switch
 Concierge, Reception, Internal call reception	 Contact (Internal), Internal call	

**Configuration table "Key configuration" /
Configuration table "Inputs and outputs" (Input ...)**

Function	Explanation	Configuration
No function	–	–
Video memory menu (AFSV... only)	Opens the video memory of the device on which this function was triggered when images are present. This function is preconfigured on the AFSV at delivery.	–
Storey call	Call signalling triggered at a device and output at a device or device group. A storey call is signalled for approx. 5 seconds. To assign a group to the storey call, a group must first be configured.	<p>Important: If this function of another device is not displayed, please check the permission settings.</p> <ul style="list-style-type: none"> • Tile symbol (only AVP...): Selection of the symbol for this tile • Tile designation (only AVP...): Selection of the designation for this tile • Label: Name displayed on the end device display (e.g. storey call (main entrance)). The name can be freely assigned. • Call destination: Select the device or group on which this function is to be executed. • Door opener: Selection of the door opener contact that can be switched by the device. • Door light: Selection of the door light contact that can be switched by the device
Send KNX telegram	A KNX telegram is sent from a device (configured KNX gateway required). Important: The effect of the KNX telegrams in the KNX system depends on the configuration of the KNX system.	<ul style="list-style-type: none"> • Tile symbol (only AVP...): Selection of the symbol for this tile • Tile designation (only AVP...): Selection of the designation for this tile • Gateway: Selection of the KNX gateway • Group address: Address of a KNX device that is to receive the KNX telegram • Feedback object: Address via which the status of a KNX device is to be reported back • Value (type of execution): <ul style="list-style-type: none"> - Toggle (change of function state: (ON becomes OFF / OFF becomes ON) - On (function is activated) - Off (function is deactivated)
Microphone off (AHF.../AHT.../AVP... only)	The microphone can be deactivated and reactivated (e.g. for enquiries in the room which the call partner should not hear at the door station). The deactivation is automatically cancelled after a call has ended.	<ul style="list-style-type: none"> • Tile symbol (only AVP...): Selection of the symbol for this tile • Tile designation (only AVP...): Selection of the designation for this tile • Recommendation: In addition, an status indicator should be configured for this function.

7 Configure devices

Indoor devices

**Configuration table “Key configuration” /
Configuration table “Inputs and outputs” (Input ...)**

Function	Explanation	Configuration
Do not disturb	If the function is active, no calls are signalled on the device for which this function was configured and the device is highlighted in red in the contact list. Callers receive an engaged tone.	<p>Important: If this function of another device is not displayed, please check the permission settings.</p> <ul style="list-style-type: none">• Tile symbol (only AVP...): Selection of the symbol for this tile• Tile designation (only AVP...): Selection of the designation for this tile• Do not disturb: Selection of the device or the group at which this function is to be activated• Value (type of execution):<ul style="list-style-type: none">- Toggle (change of function state: (ON becomes OFF / OFF becomes ON)- On (function is activated)- Off (function is deactivated)• Recommendation: In addition, an status indicator should be configured for this function.
Call	Call of an internal call destination	<ul style="list-style-type: none">• Tile symbol (only AVP...): Selection of the symbol for this tile• Tile designation (only AVP...): Selection of the designation for this tile• Call destination: Selection of the device or group to be called. Important: If a call destination is not displayed, please check the permission settings.
Call, external	Call of any external call number (configured telephony gateway and call number plan required)	<ul style="list-style-type: none">• Tile symbol (only AVP...): Selection of the symbol for this tile• Tile designation (only AVP...): Selection of the designation for this tile• Call number: Entry of any phone number including prefix
Ring tone off	If the function is active, no ring tones are output on the device for which this function was configured. Incoming calls are only signalled visually (via flashing button/call button depending on the device). After a restart of the Access system, incoming calls are indicated both acoustically and visually again.	<ul style="list-style-type: none">• Tile symbol (only AVP...): Selection of the symbol for this tile• Tile designation (only AVP...): Selection of the designation for this tile• Recommendation: In addition, an status indicator should be configured for this function.

**Configuration table "Key configuration" /
Configuration table "Inputs and outputs" (Input ...)**

Function	Explanation	Configuration
Call redirection	Incoming calls are redirected to another call destination on a device on which call redirection is active.	<p>Important: Function must be switched on in the "Switching and controlling" area. If this function of another device is not displayed, please check the permission settings.</p> <ul style="list-style-type: none"> • Tile symbol (only AVP...): Selection of the symbol for this tile • Tile designation (only AVP...): Selection of the designation for this tile • Redirect: Selection of the device on which this function is to be executed. • Destination: Device or group to which the call is redirected. • Type (configuration of call redirection): <ul style="list-style-type: none"> - Immediately: All calls are redirected immediately - After time with the option "Immediately if busy": All calls are redirected with time delay; calls on busy are redirected immediately - When busy: Only calls on busy are redirected • Recommendation: In addition, an status indicator should be configured for this function.
Switching	A switching function is triggered on a device.	<p>Important: If this function of another device is not displayed, please check the permission settings.</p> <ul style="list-style-type: none"> • Tile symbol (only AVP...): Selection of the symbol for this tile • Tile designation (only AVP...): Selection of the designation for this tile • Switching point: Selection of a device switching contact for this function • Value (type of execution): <ul style="list-style-type: none"> - Toggle (change of function state: (ON becomes OFF / OFF becomes ON) - On (configured switching point is switched on) - Off (configured switching point is switched off) • Recommendation: In addition, an status indicator should be configured for this function.
Door light (last door)	The door light contact of the door currently calling is switched, otherwise the door light contact of the door last connected to the device is switched. Optical key signalling is not possible for this function.	<ul style="list-style-type: none"> • Tile symbol (only AVP...): Selection of the symbol for this tile • Tile designation (only AVP...): Selection of the designation for this tile • Door light: Behaviour of the door light contact (works after a door call either permanently or for a specified time)

7 Configure devices

Indoor devices

**Configuration table “Key configuration” /
Configuration table “Inputs and outputs” (Input ...)**

Function	Explanation	Configuration
Doormatic	For each button/tile/input a Doormatic function can be selected. If the Doormatic function is activated, a door opener is automatically triggered according to the configuration when a door call is made.	<p>Important: The function must first be switched on and configured in the “Switching and controlling” area of the device (device-related Doormatic) or the door station (door-related Doormatic). If this function of another device is not displayed, please check the permission settings.</p> <ul style="list-style-type: none">• Tile symbol (only AVP...): Selection of the symbol for this tile• Tile designation (only AVP...): Selection of the designation for this tile• Doormatic: Selection of the device at which this function is activatable.• Value (type of execution):<ul style="list-style-type: none">- Toggle (change of function state: (ON becomes OFF / OFF becomes ON)- On (function is activated)- Off (function is deactivated)• Recommendation: In addition, an status indicator should be configured for this function.
Door opener (last door)	The door opener contact of the currently calling door is switched, otherwise the door opener contact of the door last connected to the device is switched. Optical key signalling is not possible for this function.	<ul style="list-style-type: none">• Tile symbol (only AVP...): Selection of the symbol for this tile• Tile designation (only AVP...): Selection of the designation for this tile• Door Opener: Behaviour of the door opener contact (works after a door call either permanently or for a specified time)
Notifying state (only inputs)	Signalisation which is triggered when the potential-free contact at the input terminal of the device is actively switched or closed (e.g. post detector). If a function is required, you must configure a switching input to “Notifying state” and then save it. You can then assign this switching input to a button of an indoor device, for example.	<p>Label: Displayed name in the system (e.g. Storey door - Input E1). The name can be freely assigned.</p>

LED status display (Button feedback)

- One LED status display (AFS/AHF/AHT/AFSV/AHFV/AHTV... only) can be configured for each button (e.g. button LED lights up when Doormatic is activated).
- An LED status display can be configured for functions (e.g. switching functions, call redirection) that do not trigger any calls (except door release and door light function).

Status indicator (tile feedback – only AVP ...)

- For each tile, the status is indicated upon pressing the button and during the period in which the configured function is in the triggered state (indication of the operating and trigger state of the tile).

Configuration table “Key configuration”

Function	Explanation	Configuration
No function	–	–
Receive KNX	Optical feedback on receipt of a KNX telegram	<ul style="list-style-type: none"> • Colour: Colour of the LED feedback: yellow, red; (green door release button only illuminated in one colour) • KNX gateway: Selection of the device to be monitored • Group address: Selection of the address to be monitored via which the status of a KNX device is reported back
LED status indicator	Optical feedback on triggering or occurrence of a configured event (AFS/AFSV: single click only available).	<ul style="list-style-type: none"> • Colour: Colour of the LED feedback: yellow, red; (green door release button only illuminated in one colour) • LED (Assignment of the button operating mode to be monitored; Selection depends on the configured button functions): <ul style="list-style-type: none"> - Transfer from “Single-click”: LED indicates the status of the “Single-click” operating mode - Accept from “Double-click”: LED indicates the status of the “Double-click” operating mode - Transfer from “Press key”: LED indicates the status of the “Press-key” operating mode - Transfer from “Release key”: LED indicates the status of the “Release-key” operating mode - Individual: LED indicates the status for a configurable event • Type: Filter for the function whose status is to be displayed. Filter options: Call redirection, Doormatic, Switch, Do not disturb • Device: Selection of the function to be monitored with reference to a specific device. The selection depends on the selection in the “Type” field. • Destination: Selection of the call redirection destination to be monitored.

7 Configure devices

Indoor devices

Outputs

(AHF.../AHT.../AVP... only)

Each output (switching contact) can be configured for one operating mode.

Configuration table "Inputs and outputs" (Output ...)

Operating mode	Explanation	Configuration
No function	-	-
Switching contact	Static switching operation: ON / OFF (invertible)	<ul style="list-style-type: none">• Label: Displayed name in the system (e.g. AHFV E0 - Output A1). The name can be freely assigned.• Invert: If this option is active, the idle state and working state of the switching output are exchanged (ON becomes OFF / OFF becomes ON)
Switching contact (timed)	Timed switching operation (invertible, retriggerable)	<ul style="list-style-type: none">• Label: Displayed name in the system (e.g. AHFV E0 - Output A1). The name can be freely assigned.• Switching time: Duration of how long the switch contact remains switched (0.4 s / 1-59 s / 1-10 min / 15-20-...-55 min / 1-2 h)• Invert: If this option is active, the idle state and working state of the switching output are exchanged (ON becomes OFF / OFF becomes ON)• Retrigger: The switching duration is extended by the configured time each time the button is pressed again

Switching and controlling

- The configuration of these functions refers to this device.
- The functions can be activated or deactivated.
- The functions can only be configured when they are switched on.

- Depending on the function, the complete configuration of the function is not completed until it is assigned to a button/tile.

Note

If no additional right(s) has/have been assigned yet for a function, then as of Access Professional 6.1.0, a yellow rights symbol appears next to the function in question.

Configuration table “Switching and controlling”

Function	Explanation	Configuration
User status	Provision of this function on this device. Displayed name of the device (e.g. Apartment 01 - Floor 1) in the contact list. The value is automatically taken over by “Name” from the “General” area and can be changed. The name can be freely assigned (e.g. Mr. Maier).	<ul style="list-style-type: none">• Label: Change of the displayed name in the system.• ON: The name is displayed in the contact list.• OFF: The name is not displayed in the contact list.
Video memory	Provision of this function on this device. Function and storage location for automatically and manually generated images for door calls to this device (device with video function or additional software client required in CTI mode for audio device). Possible configuration range at the door station: 1–30 seconds	Mode: <ul style="list-style-type: none">• Only record images manually: Manually recorded image is stored in the video memory. The image is triggered via the 5-way button on the device.• Record images automatically: Automatically recorded image is stored in the video memory, ...<ul style="list-style-type: none">- for event “For answered calls”: ... when the door call has been accepted.- for event “For missed calls”: ... if the door call was not accepted.• ON: The video memory is active for this device.• OFF: The video memory is not used.
Building automation URL (KNX) (AVP... only)	Provision of this function on this device. If this function is active, the “Building Automation” icon is displayed on the AVP, with which the start page of the building automation server can be called. This function is disabled by default. Important: Devices that are connected to the Access system via an AGW... cannot use this function.	<ul style="list-style-type: none">• URL: URL address of the building automation server in the form “http://[IP address with or without port specification and login data (user name and password)]” (e.g. “http://192.168.1.10:8080” or “http://192.168.1.10:8080/Default.aspx?UsrID=Gast&HP-WD=A1-B2-C3-D4-E5-F6-A7-B8-C9-D1-C2-D3-E4-F5-A6-B7-C8”)• ON: The function is active for this device• OFF: The function cannot be executed for this device
Do not disturb	Provision of this function on this device. If the function is active, no calls are signalled on the device for which this function was configured and the device is highlighted in red in the contact list.	<ul style="list-style-type: none">• Label: Change of the displayed name of the function (e.g. Mr. Maier (Do not disturb)) in the Access system for configuration on other devices (e.g. for remote triggering)• ON: The function is active for this device• OFF: The function cannot be executed for this device.

7 Configure devices

Indoor devices

Configuration table "Switching and controlling"

Function	Explanation	Configuration
Call contact	Provision of this function on this device. Switching point that is activated depending on an incoming call.	<p>Important: If this function of another device is not displayed, please check the permission settings.</p> <ul style="list-style-type: none">• Switching point: Selection of the switching point• Switch on: Trigger that activates the switching point (Start of call, Remote signals, Conversation begins, Conversation ends, Call waiting, Manual)• Switch off: Trigger that deactivates the switching point (Start of call, Conversation begins, Conversation ends, Call waiting, Manual, Time controlled: 0.4 s ... 2 h)• Note: The same trigger is not selectable for "Switch on" and "Switch off".• Options:<ul style="list-style-type: none">- Incoming calls: Function responds to incoming calls- Outgoing calls: Function responds to outgoing calls- Only for door calls: Function is only active for calls from a door station- Invert: Change of the function state of the switching point: (ON becomes OFF / OFF becomes ON)• ON: The function is active for this device• OFF: The function cannot be executed for this device.
Call redirection	Provision of this function on this device.	<ul style="list-style-type: none">• Label: Change of the displayed name of the function (e.g. Floor entrance (Call redirection)) in the Access system for configuration on other devices (e.g. for remote triggering).• ON: The function is active for this device• OFF: The function cannot be executed for this device.

Configuration table "Switching and controlling"

Function	Explanation	Configuration
Doormatic	<p>Provision of this function (device-related Doormatic) on this device.</p> <p>If the Doormatic function is activated, a door opener is automatically triggered according to the configuration when a door call is made.</p> <p>A button/tile or an input contact on another device can be configured to activate and deactivate the Doormatic function.</p> <p>The Doormatic function can also be controlled via a time profile.</p>	<ul style="list-style-type: none"> • Label: Change to the displayed name of the function (e.g. Mr Maier (doormatic)) in the Access system for configuration on other devices (e.g. for remote triggering) • Open after: Input for the time in seconds for executing the function. Configuration range: 1 - 10 seconds • Execute doormatic (for storey calls): The doormatic function is also triggered with an incoming storey call on this end device. • Execute doormatic (only during call signalling): The doormatic function is only executed if a pending door call is not answered within the configured time (see "Open after"). • Opening of (all doors): The doormatic function can be activated for all door stations via which this device can be called. • Opening of (certain doors): The doormatic function can only be activated for door stations that have been selected manually. • Door stations can be added with "+" and removed from the list with "-". <p>Important: If this function of another device is not displayed, please check the permission settings.</p> <ul style="list-style-type: none"> • ON: The function is active for this device • OFF: The function cannot be executed for this device.

7 Configure devices

External devices

JUNG Panel (TKM client)

- The control panel enables the control of various systems for home automation and door communication.
- For Siedle door communication, it is automatically connected directly to the Access system via the network using an app (Siedle TKM client for Access Professional) as a video indoor unit with touchscreen and hands-free function.
- For automatic detection in the Access system, the IP address of the Access system must be entered in the app of the operating panel.
- Currently, the app is exclusively available for JUNG touch panels: JUNG Smart Control 8 and JUNG KNX Smart Panel 8. If the touchpanel with the installed app is not located in the actual Access network, your system supervisor/network administrator must set up correct routing between the networks or Access Gateway by means of a separate network infrastructure.
- A lock screen can be activated on each touch panel, which is activated after a preset waiting time has elapsed. If there is no user interaction on the touch panel, it could also activate during a call if the call takes longer than the preset waiting time. A return to the existing connection dialog is then no longer possible. The call remains active, but cannot be deactivated by the user, and only ends after the system has allowed the call duration to expire.
- Please choose a sufficiently long waiting time.
Recommendation: average length of call + 1-2 minutes

SIP phones

- SIP phones are SIP compatible devices or third-party software clients that can be connected directly to the Access system.
- The configuration of these devices differs depending on the manufacturer.
- The connection with the Access Server is made via the network with the login data stored here.

PABX phone

- A "PABX phone" created in the Access system is a configured connection to an external phone of a third-party manufacturer. Such phones are only indirectly connected to the Access system via a SIP trunk or a PABX gateway and may be operated on an independent external system (e.g. system phone on a telephone system).
- A connection via the Access system is only established in the event of a door call or an internal call from the Access system. Normal telephony operation does not take place via the Access system. To operate a PABX phone, a SIP trunk or a PABX gateway must be configured and assigned.
- Prefixes for a SIP trunk or a PABX gateway, for the external call number and, if applicable, entire call numbers or call number blocks must be taken into account in the call number plan.

Important!

- Configuration changes are only saved permanently with "Save".
- Configuration changes that are confirmed with "Apply" must be saved with "Save".
- With every change made, the font colour of the page tab changes to red and "Save" is active.
- Software Clients and third-party devices must be manually logged off and on again to accept the changes.

Configuration table "General"

Parameters	Explanation
Name	Name for administration within the Access system (e.g. System phone reception). The name can be freely assigned and is automatically adopted by the "Show in contact list" function.
Description	Short description (e.g. System phone of the central PABX at the reception). The description is displayed in the software client.
Device type	Non-changeable information field that contains the device type.
Call number	Free extension, internally assigned call number (e.g. 121) suggested by the Access system. The call number is required for the device to log on to the Access system (user name/account name). A call number can be changed at any time by observing the call number plan. Each call number must be unique in the entire Access system.
MAC address (JUNG panel)	<p>Unique hardware address of the device. Each MAC address is unique in the entire Access system. For manually created devices, this field must be filled manually with the MAC address of the device (Format: XX:XX...XX; e.g. D4:E3:2C:00:03:2F).</p> <p>Tip: If, for example, you need to replace this device due to a service case, the following procedure for replacing a device is advised (only for JUNG Smart Control 8, JUNG KNX Smart Panel 8):</p> <ol style="list-style-type: none">1 Disconnect the faulty JUNG panel from the Access system, but do not delete it from the system administration.2 Connect the new JUNG panel to the Access system. The device appears in the system administration under "Unconfigured devices".3 Note the MAC address of the new JUNG panel and disconnect the new device and delete in the system administration.4 In the system administration, replace the MAC address of the faulty JUNG panel with the MAC address of the new JUNG panel and save.5 Disconnect the new JUNG panel from the network socket (supply) and connect it again after 10 seconds.6 The new JUNG panel performs a restart.7 The new device adopts the existing configuration and you do not need to carry out a re-configuration.
External call number (PABX phone)	Assigned phone number of the device within the external system without area code or prefix. It is not necessary to enter the prefix, as the appropriately configured connection to the external system must be selected in the "PABX gateway" field.
PABX gateway (PABX phone)	PABX gateway or SIP trunk to be selected for connecting the Access system to a remote station (e.g. telephone system at which the PABX telephone is operated).
Directory (SIP phone and JUNG panel)	Assigned directory. Optionally, an individually created directory can also be assigned.
Call profile	With the call profile you allow or forbid the device certain call or phone numbers. On the system side, no restrictions are preconfigured in the default state of the call profile.
Password (SIP phone)	The password is required for the device to log on to the Access system. The password generated by the system is used to secure access and must be changed manually. Always issue lengthy secure passwords.
Password, repetition	Repeat password entry

7 Configure devices

External devices

Configuration table "General"

Parameters	Explanation
Call waiting (SIP phone and JUNG panel)	<ul style="list-style-type: none">• Option "Signal calls even during an active call" is not set: When calling a device with an existing connection, the caller receives a busy signal. Background calls are not displayed or signalled.• Option "Signal calls even during an active call" is set: When a connection is established, further calls are output acoustically and, if necessary, optically on the called device and can be processed one after the other. Multiple simultaneous calls (max. 10 calls): Incoming calls are displayed one after the other. The calls can be processed in any order.
Door release (DTMF) (SIP phone and PABX phone)	The door release function can be triggered via the configured DTMF coding (e.g. "#61") of the multi-frequency dialling method. System-side preconfigured is "#61". The digits 0-9 and the characters * and # can be used.
Door light (DTMF) (SIP phone and PABX phone)	The door light function can be triggered via the configured DTMF coding (e.g. "#50") of the multi-frequency dialling method. System-side preconfigured is "#50". The digits 0-9 and the characters * and # can be used.

Switching and controlling

- The configuration of these functions refers to this device.
- The functions can be activated or deactivated.
- The functions can only be configured when they are switched on.
- Depending on the function, the complete configuration of the function is not completed until it is assigned to a button/tile.

Note

If no additional right(s) has/have been assigned yet for a function, then as of Access Professional 6.1.0, a yellow rights symbol appears next to the function in question.

Configuration table "Switching and controlling"

Function	Explanation	Configuration
User status	Provision of this function on this device. Displayed name of the device (e.g. System phone) in the contact list. The value is automatically taken over by "Name" from the "General" area and can be changed. The name can be freely assigned (e.g. Mr. Maier).	<ul style="list-style-type: none">• Label: Change of the displayed name in the system.• ON: The name is displayed in the contact list.• OFF: The name is not displayed in the contact list.

Configuration table "Switching and controlling"

Function	Explanation	Configuration
Video memory	Provision of this function on this device. Function and storage location for automatically and manually generated images for door calls to this device (device with video function or additional software client required in CTI mode for audio device). Possible configuration range at the door station: 1–30 seconds	<p>Mode:</p> <ul style="list-style-type: none"> • Record images manually only: Manually recorded image is stored in the video memory. • Record images automatically: Automatically recorded image is stored in the video memory, ... <p>- for event "For answered calls": ... when the door call has been accepted.</p> <p>- for event "For missed calls": ... if the door call was not accepted.</p> <ul style="list-style-type: none"> • ON: The video memory is active for this device. • OFF: The video memory is not used.
Do not disturb (SIP phone and JUNG panel)	Provision of this function on this device. If the function is active, no calls are signalled on the device for which this function was configured and the device is highlighted in red in the contact list.	<ul style="list-style-type: none"> • Label: Change of the displayed name of the function (e.g. Floor entrance (Do not disturb)) in the Access system for configuration on other devices (e.g. for remote triggering). • ON: The function is active for this device • OFF: The function cannot be executed for this device.
Call contact	Provision of this function on this device. Switching point that is activated depending on an incoming call.	<p>Important: If this function of another device is not displayed, please check the permission settings.</p> <ul style="list-style-type: none"> • Switching point: Selection of the switching point • Switch on: Trigger that activates the switching point (Start of call, Remote signals, Conversation begins, Conversation ends, Call waiting, Manual) • Switch off: Trigger that deactivates the switching point (Start of call, Conversation begins, Conversation ends, Call waiting, Manual, Time controlled: 0.4 s ... 2 h) • Note: The same trigger is not selectable for "Switch on" and "Switch off". • Options: <ul style="list-style-type: none"> - Incoming calls: Function responds to incoming calls - Outgoing calls: Function responds to outgoing calls - Only for door calls: Function is only active for calls from a door station - Invert: Change of the function state of the switching point: (ON becomes OFF / OFF becomes ON) • ON: The function is active for this device • OFF: The function cannot be executed for this device.
Call redirection (SIP phone and JUNG panel)	Provision of this function on this device.	<ul style="list-style-type: none"> • Label: Change of the displayed name of the function (e.g. System phone (Call redirection)) in the Access system for configuration on other devices (e.g. for remote triggering). • ON: The function is active for this device • OFF: The function cannot be executed for this device.

7 Configure devices

External devices

Configuration table "Switching and controlling"

Function	Explanation	Configuration
Doormatic (SIP phone and JUNG panel)	<p>Provision of this function (device-related Doormatic) on this device. If the Doormatic function is activated, a door opener is automatically triggered according to the configuration when a door call is made. A button/tile or an input contact on another device can be configured to activate and deactivate the Doormatic function. The Doormatic function can also be controlled via a time profile.</p>	<ul style="list-style-type: none">• Label: Change to the displayed name of the function (e.g. system phone (doormatic)) in the Access system for configuration on other software clients/devices (e.g. for remote triggering).• Open after: Input for the time in seconds for executing the function. Configuration range: 1 - 10 seconds.• Execute doormatic (for storey calls): The doormatic function is also triggered with an incoming storey call on this end device.• Execute doormatic (only during call signalling): The doormatic function is only executed if a pending call is not answered within the specified time.• Opening of (all doors): The doormatic function can be activated for all door stations via which this device can be called.• Opening of (certain doors): The doormatic function can only be activated for door stations that have been selected manually.• Door stations can be added with "+" and removed from the list with "-". <p>Important: If this function of another device is not displayed, please check the permission settings.</p> <ul style="list-style-type: none">• ON: The function is active for this device• OFF: The function cannot be executed for this device.

Configuration table "Switching and controlling"

Function	Explanation	Configuration
Video-URL	<p>Provision of this function for devices with a configurable video retrieval. The configuration of the SIP telephone differs depending on the manufacturer. If this function is active, a video stream of the calling door station can be output on this device. The video stream is generated by the Access system. This option is deactivated by default.</p>	<ul style="list-style-type: none"> • Format: There are 2 video stream transmission formats available: <ul style="list-style-type: none"> - Single image: JPEG single image call-up via the request variant/method "GET method / HTTP GET" (HTTP/TCP connection). - MJPEG (optionally with 1-12 frames/second): Video stream transmitted in Motion JPEG format. • Security: Optional protection of the access to the video stream by authentication: <ul style="list-style-type: none"> - Option "HTTP basic authentication": If this option is set, the video stream can only be retrieved if the retrieving device authenticates itself. - User name: Freely selectable user name for authentication of the device on the Access system. - Password: Freely definable password for the authentication of the device on the Access system. A new password must be entered for use. Always issue lengthy secure passwords (including upper and lower case letters, numbers and symbols)! • URL: A URL contains the information under which the video stream can be retrieved in the network: <ul style="list-style-type: none"> - Example without authentication: http://192.168.178.100:8080/B95AC432-2A2C-42BC-89F0-C06035547446/video.mjpeg - Example with authentication: http://[username]:[password]@192.168.178.100:8080/B95AC432-2A2C-42BC-89F0-C06035547446/video.mjpeg <p>Important: User name and password must always be manually inserted into the URL.</p> <ul style="list-style-type: none"> - Button with copy function for the video URL: By clicking on the button located behind the video URL, the video URL is cached in order to be able to insert it in a configuration interface of a device. - Alternatively, the video URL can be called via browser. A video is then displayed during a running door call. When inactive, a crossed-out camera icon appears. • ON: The function is active for this device • OFF: The function cannot be executed for this device.

7 Configure devices

External devices

CTI function

The CTI function can also be used in combination with the software clients ASC and ASHT.

This function is operated via 2 devices (e.g. PC and audio phone):

1 The software client is used for image reproduction only.

2 Audio communication takes place via an indoor audio device (AHF/AHT.../PABX phone/SIP audio phone).

Important (For details, see software client help):

- Not all functions of the software client are available in CTI mode:
 - The complete call handling is handled via the audio telephone
 - A connection is only disconnected via the audio telephone
- If an outgoing call is initiated via the software client (in CTI mode), this "call intention" is first signalled on the audio telephone. The call is not made until you lift the handset or press the PTT key (handset-less devices).

Procedure

Function	Configuration
Activating	Using Drag&Drop within the communication structure: Drag the icon of the software client onto the icon of a permitted indoor device. Both symbols are optically linked. The icon of the software client is subordinate to the indoor unit. Restart the software client.
Deactivating	Using Drag&Drop within the communication structure: Drag the icon of the software Client onto the icon of a folder where you want the software client to be located. Restart the software client.

Software clients

**Software client ASC...
(Access Software Concierge)**

The ASC is the central switchboard for the entire Access system and can be operated on a Windows-based computer.

**Software client ASHT...
(Access Software In-house
telephone)**

The ASHT is a virtual in-house telephone with video transmission capability and can be operated on a Windows-based computer.

Background calls / several simultaneous calls:

Up to 10 calls can be pending.

- **ASC...:** Multiple simultaneous calls: Incoming calls are displayed one after the other. The calls can be processed in any order.
- **ASHT...:** Multiple simultaneous calls: Door calls are displayed in the order before all other calls. The calls can be processed in any order.

Important!

- System requirements apply to the operation of the software client on one computer.
- These can be found on the login page of the Access system administration under "Downloads / Licences" under "System requirements".
- With each update of the Access system, an update note with update function may appear in the software client.
- The current version is also available for download in the "Downloads / Licences" section under "Siedle Access Software".
- Configuration changes are only saved permanently with "Save".
- Configuration changes that are confirmed with "Apply" must be saved with "Save".
- With every change made, the font colour of the page tab changes to red and "Save" is active.
- Software Clients and third-party devices must be manually logged off and on again to accept the changes.
- If the PC with the installed software client is not located in the actual Access network, your system supervisor/network administrator must set up correct routing between the networks by means of a separate network infrastructure. For this, extended knowledge of the network is required.

7 Configure devices

Software clients (ASC.../ASHT...)

Configuration table "General"

Parameters	Explanation
Name	Name for administration within the Access system (e.g. Reception). The name can be freely assigned and is automatically adopted by the "Show in contact list" function.
Description	Short description (e.g. Software client on mobile workstation). The description is displayed in the software client.
Device type	Non-changeable information field that contains the device type.
Call number	Free extension, internally assigned call number (e.g. 121) suggested by the Access system. A call number can be changed at any time by observing the call number plan. Each call number must be unique in the entire Access system.
Directory	Assigned directory. Optionally, an individually created directory can also be assigned.
Call profile	With the call profile you allow or forbid the device certain call or phone numbers. On the system side, no restrictions are preconfigured in the default state of the call profile.
User name	The username is required for the software client to log on to the Access system. The username generated by the system can be freely changed.
Password	The password is required for the software client to log on to the Access system. The password generated by the system is used to secure access and can be freely changed. A new password must be entered for use. Always issue lengthy secure passwords (including upper and lower case letters, numbers and symbols).
Password, repetition	Repeat password entry
Call waiting	<ul style="list-style-type: none">• Option "Transferring calls even during an active call" is not set: When calling a device with an existing connection, the caller receives a busy signal. Background calls are not displayed or signalled.• Option "Transferring calls even during an active call" is set: If a connection is established, further calls are optically output on the called device and can be processed one after the other.• Multiple simultaneous calls (max. 10 calls): Incoming calls are displayed one after the other. The calls can be processed in any order.

Switching and controlling

- The configuration of these functions refers to software client.
- The functions can be activated or deactivated.
- The functions can only be configured when they are switched on.
- Depending on the function, the complete configuration of the function is not completed until it is assigned to a button/tile.

Note

If no additional right(s) has/have been assigned yet for a function, then as of Access Professional 6.1.0, a yellow rights symbol appears next to the function in question.

Configuration table “Switching and controlling”

Function	Explanation	Configuration
User status	Provision of this function on this software client. Displayed name of the software client (e.g. Reception) in the contact list. The value is automatically taken over by “Name” from the “General” area and can be changed. The name can be freely assigned (e.g. Mr. Maier).	<ul style="list-style-type: none">• Label: Change of the displayed name in the system.• ON: The name is displayed in the contact list.• OFF: The name is not displayed in the contact list.
Video memory	Provision of this function on this software client. Function and storage location for automatically and manually generated images for door calls to this software client (alternative operating option: software client in CTI mode to audio device) Possible configuration range at the door station: 1–30 seconds.	<p>Mode:</p> <ul style="list-style-type: none">• Record images manually only: Manually recorded image is stored in the video memory.• Record images automatically: Automatically recorded image is stored in the video memory, ...<ul style="list-style-type: none">- for event “For answered calls”: ... when the door call has been accepted.- for event “For missed calls”: ... if the door call was not accepted.• ON: The video memory is active for this software client.• OFF: The video memory is not used.
Do not disturb	Provision of this function on this software client. If the function is active, no calls are signalled on the software client or on another device for which this function was configured and the software client/device is highlighted in red in the contact list.	<ul style="list-style-type: none">• Label: Change of the displayed name of the function (e.g. Mr. Maier (Do not disturb)) in the Access system for configuration on other devices (e.g. for remote triggering).• ON: The function is active for this software client• OFF: The function cannot be executed for this software client.

7 Configure devices

Software clients (ASC.../ASHT...)

Configuration table "Switching and controlling"

Function	Explanation	Configuration
Call contact	Provision of this function on this software client. Switching point that is activated depending on an incoming call.	<p>Important: If this function of another device is not displayed, please check the permission settings.</p> <ul style="list-style-type: none"> • Switching point: Selection of the switching point • Switch on: Trigger that activates the switching point (Start of call, Remote signals, Conversation begins, Conversation ends, Call waiting, Manual) • Switch off: Trigger that deactivates the switching point (Start of call, Conversation begins, Conversation ends, Call waiting, Manual, Time controlled: 0.4 s ... 2 h) • Note: The same trigger is not selectable for "Switch on" and "Switch off". • Options: <ul style="list-style-type: none"> - Incoming calls: Function responds to incoming calls - Outgoing calls: Function responds to outgoing calls - Only for door calls: Function is only active for calls from a door station - Invert: Change of the function state of the switching point: (ON becomes OFF / OFF becomes ON) • ON: The function is active for this software client • OFF: The function cannot be executed for this software client.
Call redirection	Provision of this function on this software client.	<ul style="list-style-type: none"> • Label: Change of the displayed name of the function (e.g. Floor entrance (Call redirection)) in the Access system for configuration on other devices (e.g. for remote triggering). • ON: The function is active for this software client • OFF: The function cannot be executed for this software client.
Doormatic	Provision of this function (device-related Doormatic) on this software client. If the Doormatic function is activated, a door opener is automatically triggered according to the configuration when a door call is made. The function in the software client or a button/tile or an input contact on another device can be configured to activate and deactivate the Doormatic function. The Doormatic function can also be controlled via a time profile.	<ul style="list-style-type: none"> • Label: Change of the displayed name of the function (e.g. Mr. Maier (Doormatic)) in the Access system for configuration on other devices (e.g. for remote triggering) • Automatically open after: Free entry of the time for executing the function in seconds. Configuration range: 1-10 seconds • Automatically open from all Doors: The Doormatic function can be activated for all door stations from which this device can be called. • Automatically open from these Doors: The Doormatic function can only be activated for door stations that have been selected manually. Door stations can be added with "+" and removed from the list with "-". <p>Important: If this function of another device is not displayed, please check the permission settings.</p> <ul style="list-style-type: none"> • ON: The function is active for this software client • OFF: The function cannot be executed for this software client.

CTI function

The CTI function can also be used in combination with the software clients ASC and ASHT.

This function is operated via 2 devices (e.g. PC and audio phone):

1 The software client is used for image reproduction only.

2 Audio communication takes place via an indoor audio device (AHF/AHT.../PABX phone/SIP audio phone).

Important (For details, see software client help):

- Not all functions of the software client are available in CTI mode:
 - The complete call handling is handled via the audio telephone
 - A connection is only disconnected via the audio telephone
- If an outgoing call is initiated via the software client (in CTI mode), this "call intention" is first signalled on the audio telephone. The call is not made until you lift the handset or press the PTT key (handset-less devices).

Procedure

Function	Configuration
Activating	Using Drag&Drop within the communication structure: Drag the icon of the software client onto the icon of a permitted indoor device. Both symbols are optically linked. The icon of the software client is subordinate to the indoor unit. Restart the software client.
Deactivating	Using Drag&Drop within the communication structure: Drag the icon of the software Client onto the icon of a folder where you want the software client to be located. Restart the software client.

7 Configure devices

Software clients (ASC.../ASHT...)

Advanced Concierge video functions

The “Advanced concierge video functions” can be used with the Access software concierge, both individually and together, and comprise the following functions:

Function	Explanation	Models
Door video forwarding Forwarding a door station's camera video image for an ongoing and on-hold door conversation to a subsequently internally called user for the purpose of a query. The internal user talks to the caller but sees the door station video image with the waiting visitor.	<p>A visitor rings at a video door station in front of a closed entrance area. A concierge answers and the visitor tells them who they want to visit. As the visitor was not registered with the concierge, they check with the resident for security reasons. They put the current door conversation on hold and use the Access software concierge to call the resident (internal query) to obtain their permission to let the visitor in. The resident answers and the concierge tells them about the visitor who is waiting. If required, the concierge can use the “Forward door video” function to forward the video image from the video door station camera to the resident (internal query with video).</p> <p>The resident speaks to the concierge and sees the video image from the door station showing the visitor who is waiting. The visitor is not involved in this process and awaits the concierge's response.</p>	<ul style="list-style-type: none">• Video door station camera• Access Software Concierge

Function	Explanation	Models
<p>Concierge camera Transfer of a video image from a camera that is explicitly provided for use with the Access software concierge (e.g. camera in the foyer or on a reception desk) to an internally called user. This function can be automated with the “Start video automatically” option in the general settings under “Advanced concierge video functions”.</p>	<p>A visitor enters a building with a foyer or reception desk. A concierge greets the visitor. The visitor tells them who they want to visit. As the visitor was not registered with the concierge, they check with the resident for security reasons.</p> <p>They use the Access software concierge to call the resident (internal call) to obtain their permission to let the visitor in. The resident answers and the concierge tells them about the visitor who is waiting. If required, the concierge can use the “Concierge camera” function to transfer the video image from the foyer or reception desk camera to the resident (internal call with video). The resident speaks to the concierge and sees the video image showing the visitor who is waiting. The visitor is not involved in this process and awaits the concierge’s response.</p>	<ul style="list-style-type: none"> • External IP video camera in the usage environment of the Access software concierge (e.g. reception desk). • Access Software Concierge

7 Configure devices

Software clients (ASC.../ASHT...)

The “Advanced concierge video functions” can be used with the Access software concierge. To do so, these must be set up in the Access system management and in the Access software concierge:

Access system administration

Function	Configuration
Activating	Via Drag&Drop within the communication structure: Drag the IP camera symbol to the software client symbol. Both symbols are linked. The IP camera symbol is subordinate to the software client. Perform a restart of the software client and activate the display for the function in the software client settings.
Deactivating	Via Drag&Drop within the communication structure: Drag the IP camera symbol onto the symbol of a folder where the IP camera should go. Perform a restart of the software client and deactivate the display for the function in the software client settings.

Access Software Concierge

Function	Configuration
Activating	In the settings under “General”, activate the desired options for “Advanced concierge video functions” in order to be able to use the functions in the Access software concierge.
Deactivating	In the settings under “General”, deactivate the desired options for “Advanced concierge video functions” in order to hide the functions in the Access software concierge.

Software clients (Siedle app)

Siedle app

- The Siedle App is the mobile connection to the door communication of the Access system.
- The Siedle App is optimized for use on the iPhone, iPad and Android smartphone, and can be used on Android tablets - but not optimized for this.
- For commissioning and operation, an Internet connection is required for the Access system and the mobile device with installed Siedle App.
- Communication is encrypted via the Siedle server on the Internet.
- Commissioning of the Siedle App works for iOS and Android within a few seconds – scan in the QR code from the Access system via the Siedle App and you are done.
- When changing the configuration of the Access system (e.g. changing the permission configuration), the update of an operating Siedle App can take up to several minutes in some cases. This is partly due to the system and also depends on the continuous network connection.
- For operation of the Siedle App on a mobile device, the respective system requirements in the App Store / Google Play Store apply.
- For each mobile device with installed Siedle App, a device must be created in the Access system.
- The Siedle App is only accessible for devices in the Access system.
- External calls to the Siedle App are only possible via a configured connection (created PABX phone via SIP trunk or PABX gateway).

New functions with the Siedle app

As of Access Professional 7.1, the new “Switching & signalling” and “Storey call” functions can be used with the Siedle app from Version 1.6.0 and above.

Notes on system recovery

For security reasons, the Siedle app can only be operated after an Access system has been restored if the installed Siedle app matches the registration status on the local Access system and the Siedle server in the cloud and no changes have occurred (e.g. replacement of the smartphone, re-registration due to a new installation, etc.). Otherwise, the Siedle app must be re-registered with a new QR code.

Background calls / several simultaneous calls:

After the first incoming call, the connection is engaged for further calls. Only one call can be displayed and accepted at any time.

Important!

- Configuration changes are only saved permanently with “Save”.
- Configuration changes that are confirmed with “Apply” must be saved with “Save”.
- With every change made, the font colour of the page tab changes to red and “Save” is active.

7 Configure devices

Software clients (Siedle app)

Configuration table "General"

Parameters	Explanation
Name	Name for administration within the Access system (e.g. Siedle App). The name can be freely assigned and is automatically adopted by the "Show in contact list" function.
Description	Short description (e.g. mobile intercom of the reception). The description is displayed in the software client.
Device type	Non-changeable information field that contains the device type.
Call number	Free extension, internally assigned call number (e.g. 121) suggested by the Access system. A call number can be changed at any time by observing the call number plan. Each call number must be unique in the entire Access system.
Registration	QR code for the one-time registration of a mobile device via the Siedle App.
Valid Until	Time until the QR code can be used for the one-time registration of a mobile device with installed Siedle App. After the validity time has expired, a new QR code must be generated via the Access system. Notes on the QR Code: <ul style="list-style-type: none">• Each QR Code is valid for a maximum of 1 month. After this period the QR Code becomes invalid and must be renewed.• Each QR Code can be generated as a PDF file and forwarded to the customer in electronic/ printed form.• A still valid QR Code can be deleted and replaced by a newly generated QR Code.

Button configuration

- Up to 44 buttons (tiles) can be configured per app.
- Each button (tile) can be assigned a function.
- The name and icons of the tiles can be assigned individually.
- Each tile features an optical feedback signal (e.g. Active signal due to a colour-changing tile when the function is switched on).
- There are different icons (e.g. light, group call,...) to choose from.
- Each function features a pre-configured icon and label.

Status indicator (tile feedback)























A status indicator can be configured for each tile. This can be carried out using two versions:

- Indication of the operating and trigger state of the tile: The status is indicated upon pressing the button and during the period in which the configured function is in the triggered state.
- Indication of system feedback: The status indicator of the tile shows technical system-side feedback which confirms that the triggered function is in the desired state (e.g. sensor feedback that a garage door is open).

Tip

- A time profile can also be used to execute several switching functions (such as switching doormatic and call rerouting on/off) at the same time via a tile.
- If this function is not displayed, please check the permission settings.

Use of symbols

	Door light, switch light, switch door light		Heating		Switch on, switched on, switch is on
	Door release, release door, trigger the door release		Ventilation		Switch off, switched off, switch is off
	Open garage door/open		Cooling		Movement sensor, movement sensor module
	Close garage door/shutter/closed		Info/message		Water sensor, water detector
	Open shutter/open		Warning/warning message		DND (Do not disturb)
	Switching, switch		Window contact, window contact detector		Call rerouting, reroute calls
	Alarm system		Door contact, door contact detector		Storey call, call from the storey door or apartment entrance door
	Air conditioning		Mail notification system, letterbox notification system		

Configuration table "Key configuration"

Function	Explanation	Configuration
No function	–	–
Storey call	Call signalling triggered at a device and output at a device or device group. A storey call is signalled for approx. 5 seconds. To assign a group to the storey call, a group must first be configured.	<p>Important: If this function of another device is not displayed, please check the permission settings.</p> <ul style="list-style-type: none"> • Tile symbol: Selection of the symbol for this tile • Tile label: Selection of the designation for this tile • Label: Name displayed on the end device display (e.g. storey call (main entrance)). The name can be freely assigned. • Call destination: Select the device or group on which this function is to be executed. • Door opener: Selection of the door opener contact that can be switched by the device. • Door light: Selection of the door light contact that can be switched by the device
Tile without function	Tile without triggerable switching function for use as a configurable status indicator (visual signalling) of a function status on the Siedle app, which was changed via another Access system device (such as a switching function that was triggered via an indoor station). The LED status indicator must also be configured within this function in order to be able to use it.	<ul style="list-style-type: none"> • Tile symbol: Selection of the symbol for this tile • Tile label: Selection of the designation for this tile <p>LED status indicator</p> <ul style="list-style-type: none"> • Individual: Tile shows the status for a configurable event: <ul style="list-style-type: none"> - Type: Filter for the function whose status is to be displayed. Filter options: Call redirection, Doormatic, Switch, Do not disturb

7 Configure devices

Software clients (Siedle app)

Configuration table “Key configuration”

Function	Explanation	Configuration
Do not disturb	If the function is active, no calls are signalled on the device for which this function was configured and the device is highlighted in red in the contact list. Callers receive an engaged tone.	Important: If this function of another device is not displayed, please check the permission settings. <ul style="list-style-type: none">• Tile symbol: Selection of the symbol for this tile• Tile label: Selection of the designation for this tile• Do not disturb: Selection of the device or the group at which this function is to be activated• Value (type of execution):<ul style="list-style-type: none">- Toggle (change of function state: (ON becomes OFF / OFF becomes ON)- On (function is activated)- Off (function is deactivated)
Call redirection	Incoming calls are redirected to another call destination on a device on which call redirection is active.	Important: Function must be switched on in the “Switching and controlling” area. If this function of another device is not displayed, please check the permission settings. <ul style="list-style-type: none">• Tile symbol: Selection of the symbol for this tile• Tile label: Selection of the designation for this tile• Redirect: Selection of the device on which this function is to be executed.• Destination: Device or group to which the call is redirected.• Type (configuration of call redirection):<ul style="list-style-type: none">- Immediately: All calls are redirected immediately- After time with the option “Immediately if busy”: All calls are redirected with time delay; calls on busy are redirected immediately- When busy: Only calls on busy are redirected
Switching	A switching function is triggered on a device.	Important: If this function of another device is not displayed, please check the permission settings. <ul style="list-style-type: none">• Tile symbol: Selection of the symbol for this tile• Tile label: Selection of the designation for this tile• Switching point: Selection of a device switching contact for this function• Value (type of execution):<ul style="list-style-type: none">- Toggle (change of function state: (ON becomes OFF / OFF becomes ON)- On (configured switching point is switched on)- Off (configured switching point is switched off)

Configuration table "Key configuration"

Function	Explanation	Configuration
Door light (last door)	The door light contact of the door currently calling is switched, otherwise the door light contact of the door last connected to the device is switched. Optical key signalling is not possible for this function.	<ul style="list-style-type: none">• Tile symbol: Selection of the symbol for this tile• Tile label: Selection of the designation for this tile• Door light: Behaviour of the door light contact (works after a door call either permanently or for a specified time)
Doormatic	A doormatic function can be selected for each tile. When the doormatic function is active, then in the event of a door call, a door release is automatically triggered according to the configuration.	<p>Important: The function must first be switched on and configured in the "Switching and controlling" area of the device (device-related Doormatic) or the door station (door-related Doormatic). If this function of another device is not displayed, please check the permission settings.</p> <ul style="list-style-type: none">• Tile symbol: Selection of the symbol for this tile• Tile label: Selection of the designation for this tile• Doormatic: Selection of the device at which this function is activatable.• Value (type of execution):<ul style="list-style-type: none">- Toggle (change of function state: (ON becomes OFF / OFF becomes ON)- On (function is activated)- Off (function is deactivated)
Door opener (last door)	The door opener contact of the currently calling door is switched, otherwise the door opener contact of the door last connected to the device is switched. Optical key signalling is not possible for this function.	<ul style="list-style-type: none">• Tile symbol: Selection of the symbol for this tile• Tile label: Selection of the designation for this tile• Door Opener: Behaviour of the door opener contact (works after a door call either permanently or for a specified time)

7 Configure devices

Software clients (Siedle app)

Status indicator (tile feedback)

An LED status display can be configured for functions (e.g. switching functions, call redirection) that do not trigger any calls (except door release and door light function).

A status indicator can be configured for each tile. This can be carried out using two versions:

- Indication of the operating and trigger state of the tile: The status is indicated upon pressing the button and during the period in which the configured function is in the triggered state.
- Indication of system feedback: The status indicator of the tile shows technical system-side feedback which confirms that the triggered function is in the desired state (e.g. sensor feedback that a garage door is open).

Configuration table "Key configuration"

Function	Explanation	Configuration
No function	–	–
LED status indicator	Visual feedback when a configured event is triggered or occurs.	<ul style="list-style-type: none">• Take from tile: Status indicator according to the operating state of the tile• Individual: Tile shows the status for a configurable event:<ul style="list-style-type: none">- Type: Filter for the function whose status is to be displayed. Filter options: Call redirection, Doormatic, Switch, Do not disturb- Device: Selection of the function to be monitored with reference to a specific device. The selection depends on the selection in the "Type" field.- Rerouting destination: Selection of the call rerouting destinations to be monitored.

Switching and controlling

- The configuration of these functions refers to software client.
- The functions can be activated or deactivated.
- The functions can only be configured when they are switched on.

Note

If no additional right(s) has/have been assigned yet for a function, then as of Access Professional 6.1.0, a yellow rights symbol appears next to the function in question.

Configuration table “Switching and controlling”

Function	Explanation	Configuration
User status	Provision of this function on this app. Displayed name of the app (e.g. Siedle App) in the contact list. The value is automatically taken over by “Name” from the “General” area and can be changed. The name can be freely assigned.	<ul style="list-style-type: none">• Label: Change of the displayed name in the system.• ON: The name is displayed in the contact list.• OFF: The name is not displayed in the contact list.
Video memory	Provision of this function on this app. Function and storage location for automatically and manually generated images for door calls to this app. Possible configuration range at the door station: 1-30 seconds.	Mode: <ul style="list-style-type: none">• Record images automatically: Automatically recorded image is stored in the video memory, ...<ul style="list-style-type: none">- for event “For answered calls”: ... when the door call has been accepted.- for event “For missed calls”: ... if the door call was not accepted.• ON: The video memory is active for this software client.• OFF: The video memory is not used.
Do not disturb	Provision of this function on this software client. If the function is active, no calls are signalled on the software client or on another device for which this function was configured and the software client/device is highlighted in red in the contact list.	<ul style="list-style-type: none">• Label: Change of the displayed name of the function (e.g. Mr. Maier (Do not disturb)) in the Access system for configuration on other devices (e.g. for remote triggering).• ON: The function is active for this software client• OFF: The function cannot be executed for this software client.
Call redirection	Provision of this function on this software client.	<ul style="list-style-type: none">• Label: Change of the displayed name of the function (e.g. Floor entrance (Call redirection)) in the Access system for configuration on other devices (e.g. for remote triggering).• ON: The function is active for this software client• OFF: The function cannot be executed for this software client.

7 Configure devices

Software clients (Siedle app)

Configuration table "Switching and controlling"

Function	Explanation	Configuration
Doormatic	Provision of this function (device-related Doormatic) on this software client. If the Doormatic function is activated, a door opener is automatically triggered according to the configuration when a door call is made. The function in the software client or a button/tile or an input contact on another device can be configured to activate and deactivate the Doormatic function. The Doormatic function can also be controlled via a time profile.	<ul style="list-style-type: none">• Label: Change of the displayed name of the function (e.g. Mr. Maier (Doormatic)) in the Access system for configuration on other devices (e.g. for remote triggering)• Automatically open after: Free entry of the time for executing the function in seconds. Configuration range: 1-10 seconds• Automatically open from all Doors: The Doormatic function can be activated for all door stations from which this device can be called.• Automatically open from these Doors: The Doormatic function can only be activated for door stations that have been selected manually. Door stations can be added with "+" and removed from the list with "-". Important: If this function of another device is not displayed, please check the permission settings.• ON: The function is active for this software client• OFF: The function cannot be executed for this software client.

Door stations

Access door loudspeaker controller (ATLC)

- The ATLC is a Siedle controller for connecting the components of a door station to the Access system.
- During start-up, the ATLC registers the connected components and any existing door camera with the system.
- The ATLC must be restarted after the initial installation or if changes have been made.
- After calling up the configuration page, the changes to the ATLC are displayed and can then be configured.

Tip: If you replace this Access door loudspeaker controller, for instance due to a service, then save the new MAC address in this screen before carrying out the replacement. This means that the previous ATLC is replaced by the new ATLC with the existing configuration and there is no need to carry out a new configuration.

Digital video decoupling

As of Access Professional 7.1, the video streams from all cameras which are operated in the Access system via an ATLC... (Access system cameras and system-free analogue cameras via AIVS...) can each be used individually for professional video surveillance (e.g. for continuous video recording) or for other display systems (e.g. building automation panels, for displaying the video feed of a door call). The function is subject to licence and can be optionally configured as a function module.

Inputs/Outputs

- The device is equipped with 1 switching input and 3 switching outputs.
- Optionally it can be extended with the "Access door loudspeaker controller extension ATLCE 670-..." by 2 switching inputs and 4 switching outputs.
- Up to 3 ATLCE 670-... can be connected to an ATLC 670-... via ribbon cable.
- A maximum of 7 switching inputs and 15 switching outputs (14 of which are potential-free) are possible in full configuration.

Important!

- For configuration, the device must be in the communication structure "Project".
- A complete configuration in the "Unconfigured devices" folder is not possible because devices in this folder do not have any permissions.
- Configuration changes are only saved permanently with "Save".
- Configuration changes that are confirmed with "Apply" must be saved with "Save".
- With every change made, the font colour of the page tab changes to red and "Save" is active.
- With saved changes that require a device restart, a yellow dot in the page tab and a yellow warning triangle in the header of the page indicate that the device must be restarted.
- A device restart is possible on the same page or via the dashboard.
- If this device is deleted within the communication structure, it is moved to the "Unconfigured devices" folder.
- If this device is deleted from the "Unconfigured Devices" folder, it will be removed from the communication structure.
- However, if this device is still connected to the Access system, it will reappear in the "Unconfigured Devices" folder after the Access system is restarted.

7 Configure devices

Door stations

Configuration table "General"

Parameters	Explanation
Name	Name for administration within the Access system (e.g. Floor entrance). The name can be freely assigned and is automatically adopted by the "Show in contact list" function.
Description	Short description (e.g. Building 5 - level 3). The description is displayed in the software client.
Device type	Non-changeable information field that contains the device type.
Call number	Free extension, internally assigned call number (e.g. 121) suggested by the Access system. Each call number must be unique in the entire Access system.
MAC address	Unique hardware address of the device. The MAC address is automatically entered for each device detected by the system. Each MAC address is unique in the entire Access system. For manually created devices, this field must be filled manually with the MAC address of the device (Format: XX:XX:XX; e.g. D4:E3:2C:00:03:2F). Tip: If, for example, you need to replace this device due to a service case, save the new MAC address in this mask before replacing it. This causes the new device to adopt the existing configuration and you do not have to completely reconfigure it.
Call profile	With the call profile you allow or forbid the device certain call or phone numbers. On the system side, no restrictions are preconfigured in the default state of the call profile.
Door camera	Unchangeable information field which indicates whether a video camera has been detected at this door station.
Speech volume	Speech output volume, adjustable from 1 to 5. The setting value 1 complies with a minimum audible volume and can be increased step by step.
Microphone	Microphone sensitivity for voice input, adjustable from 1 to 5. The setting value 1 complies with a minimum microphone sensitivity and can be increased step by step.
Call acknowledgement	Acoustic acknowledgement (audio feedback) at the door station after pushing a call button. There are three options to choose from: <ul style="list-style-type: none">• None: The function is deactivated• Simple: A standard acknowledgement tone is output for each call.• Individual: For selected call destinations, the standard acknowledgement tone is replaced by an individualised acknowledgement tone. Different call acknowledgement tones can be assigned to different call destinations. For information on importing your own audio files, please contact the Access Service Centre at the Furtwangen plant.
ZAM acknowledgement	Only visible when the Status display module (ZAM 670-...) is installed. Acoustic status acknowledgement (audio feedback) at the door station for signalling the different statuses: "Call", "Not available", "Door release" and "Speech". <ul style="list-style-type: none">• Option activated: The respective status is signalled acoustically.• Option disabled: The respective status is not signalled acoustically. Tone sequences: <ul style="list-style-type: none">• Call (20s): 1s signalling and 4s pause• Not available (3s): 0.1s signalling and 0.4s pause• Door release (3s): 3s signalling• Speech (2s): 0.1s signalling and 0.1s pause

Button configuration

- The number of configurable buttons depends on the connected modules or Bus call button matrices.
- Each button on the door station can be assigned a function.

Inputs

Each input can be configured for a function that is to be triggered when the input is actively switched or closed.

Tip

With a time profile, several switching functions (e.g. switching Doormatic and call forwarding on/off) can also be executed at the same time via a button/tile or an input contact.

**Configuration table "Key configuration" /
Configuration table "Inputs and outputs" (Input ...)**

Function	Explanation	Configuration
No function	-	-
Storey call	Call signalling triggered at a device and output at a device or device group. A storey call is signalled for approx. 5 seconds. To assign a group to the storey call, a group must first be configured.	Important: If this function of another device is not displayed, please check the permission settings. <ul style="list-style-type: none"> • Label: Name displayed on the end device display (e.g. storey call (main entrance)). The name can be freely assigned. • Call destination: Select the device or group on which this function is to be executed. • Door opener: Selection of the door opener contact that can be switched by the device. • Door light: Selection of the door light contact that can be switched by the device
Send KNX telegram	A KNX telegram is sent from a device (configured KNX gateway required). Important: The effect of the KNX telegrams in the KNX system depends on the configuration of the KNX system.	<ul style="list-style-type: none"> • Gateway: Selection of the KNX gateway • Group address: Address of a KNX device that is to receive the KNX telegram • Feedback object: Address via which the status of a KNX device is to be reported back • Value (type of execution): <ul style="list-style-type: none"> - Toggle (change of function state: (ON becomes OFF / OFF becomes ON) - On (function is activated) - Off (function is deactivated)
Do not disturb	If the function is active, no calls are signalled on the device for which this function was configured and the device is highlighted in red in the contact list. Callers receive an engaged tone.	Important: If this function of another device is not displayed, please check the permission settings. <ul style="list-style-type: none"> • Do not disturb: Selection of the device or the group at which this function is to be activated • Value (type of execution): <ul style="list-style-type: none"> - Toggle (change of function state: (ON becomes OFF / OFF becomes ON) - On (function is activated) - Off (function is deactivated)
Call, external	Call of any external call number (configured telephony gateway and call number plan required)	Call number: Entry of any phone number including prefix

7 Configure devices

Door stations

**Configuration table "Key configuration" /
Configuration table "Inputs and outputs" (Input ...)**

Function	Explanation	Configuration
Call redirection	Incoming calls are redirected to another call destination on a device on which call redirection is active.	<p>Important: Function must be switched on in the "Switching and controlling" area. If this function of another device is not displayed, please check the permission settings.</p> <ul style="list-style-type: none"> • Redirect: Selection of the device on which this function is to be executed. • Destination: Device or group to which the call is redirected. • Type (configuration of call redirection): <ul style="list-style-type: none"> - Immediately: All calls are redirected immediately - After time with the option "Immediately if busy": All calls are redirected with time delay; calls on busy are redirected immediately - When busy: Only calls on busy are redirected
Switching	A switching function is triggered on a device.	<p>Important: If this function of another device is not displayed, please check the permission settings.</p> <ul style="list-style-type: none"> • Switching point: Selection of a device switching contact for this function • Value (type of execution): <ul style="list-style-type: none"> - Toggle (change of function state: (ON becomes OFF / OFF becomes ON) - On (configured switching point is switched on) - Off (configured switching point is switched off) • Recommendation: In addition, an status indicator should be configured for this function.
Door light	The door light contact on this or another device is switched. Important: Function must be switched on in the "Switching and controlling" area of the respective device.	-
Doormatic	For each button/input a Doormatic function can be selected. If the Doormatic function is activated, a door opener is automatically triggered according to the configuration when a door call is made.	<p>Important: The function must first be switched on and configured in the "Switching and controlling" area of the device (device-related Doormatic) or the door station (door-related Doormatic). If this function of another device is not displayed, please check the permission settings.</p> <ul style="list-style-type: none"> • Doormatic: Selection of the device at which this function is activatable. • Value (type of execution): <ul style="list-style-type: none"> - Toggle (change of function state: (ON becomes OFF / OFF becomes ON) - On (function is activated) - Off (function is deactivated) • Recommendation: In addition, an status indicator should be configured for this function.

**Configuration table "Key configuration" /
Configuration table "Inputs and outputs" (Input ...)**

Function	Explanation	Configuration
Door call	Call of an internal call destination	Call destination: Selection of the device or group to be called. Important: If a call destination is not displayed, please check the permission settings.
Notifying state (only inputs)	Signalisation which is triggered when the potential-free contact at the input terminal of the device is actively switched or closed (e.g. post detector). If a function is required, you must configure a switching input to "Notifying state" and then save it. You can then assign this switching input to a button of an indoor device, for example.	Label: Displayed name in the system (e.g. Storey door - Input E1). The name can be freely assigned.

7 Configure devices

Door stations

Outputs

- The labels (designations) of the freely configurable switching outputs are used for identification within the Access system.
- Select meaningful labels.

Voltage mode at output A1

- At output A1 (terminals 23,24) of the ATLC, DC operation or AC operation can be configured for door release.
- If the function is active, a DC or AC voltage is applied to output A1 when the door release is triggered.

Configuration table "Inputs and Outputs" (Output...)

Operating mode	Explanation	Configuration
No function	-	-
Function (Door light)	Display indicator for this function. The configuration is carried out in the "Switching & controlling" area. This function can only be assigned to a non-configured output.	-
Function (Door release)	Display indicator for this function. The configuration is carried out in the "Switching & controlling" area. This function can only be assigned to a non-configured output.	-
Switching contact	Static switching operation: ON / OFF (invertible)	<ul style="list-style-type: none">• Label: Displayed name in the system (e.g. Floor entrance - Output A1). The name can be freely assigned.• Invert: If this option is active, the idle state and working state of the switching output are changed (ON becomes OFF / OFF becomes ON)
Switching contact (timed)	Timed switching operation (invertible, retriggerable)	<ul style="list-style-type: none">• Label: Displayed name in the system (e.g. Floor entrance - Output A2). The name can be freely assigned.• Switching time: Duration of how long the switching contact remains switched (0.4 s / 1-59 s / 1-10 min / 15-20-...-55 min / 1-2 h)• Invert: If this option is active, the idle state and working state of the switching output are exchanged (ON becomes OFF / OFF becomes ON)• Retriigger: The switching duration is extended by the configured time each time the button is pressed again

Switching and controlling

- The configuration of these functions refers to this device.
- The functions can be activated or deactivated.
- The functions can only be configured when they are switched on.
- Depending on the function, the complete configuration of the function is not completed until it is assigned to a button/tile.

Note

If no additional right(s) has/have been assigned yet for a function, then as of Access Professional 6.1.0, a yellow rights symbol appears next to the function in question.

Configuration table “Switching and controlling”

Function	Explanation	Configuration
User status	Provision of this function on this device. Displayed name of the device (e.g. Floor entrance - Floor 1) in the contact list. The value is automatically taken over by “Name” from the “General” area and can be changed. The name can be freely assigned (e.g. Mr. Maier).	<ul style="list-style-type: none">• Label: Change of the displayed name in the system.• ON: The name is displayed in the contact list.• OFF: The name is not displayed in the contact list.
Video memory	Provision of this function on this device. This function requires a door camera.	<ul style="list-style-type: none">• Record image after [x] seconds: Time from the triggered door call (pressing the call button) at this door station until the camera image is saved. Possible configuration range at the door station: 4–30 seconds• ON: The video memory is active for this device.• OFF: The video memory cannot be used.
Do not disturb	Provision of this function on this device. If the function is active, no calls are signalled on the device for which this function was configured and the device is highlighted in red in the contact list.	<ul style="list-style-type: none">• Label: Change of the displayed name of the function (e.g. Floor entrance (Do not disturb)) in the Access system for configuration on other devices (e.g. for remote triggering).• ON: The function is active for this device• OFF: The function cannot be executed for this device.
ONVIF camera share	Provision of this function on this device. If the function is active, then a video stream can be enabled for each door camera for access via digital video decoupling.	<ul style="list-style-type: none">• Profile name: Freely-configurable name for the door camera to differentiate the individual video streams when setting up and using digital video decoupling.• Resolution: Displayed image size (e.g. 352 x 288) and compression method (e.g. H.264) of the video channel. Example: “352 x 288 (H.264)”.• RTSP: Door camera’s video stream which, if use is enabled, is provided via the Access system’s digital video decoupling via ONVIF.

7 Configure devices

Door stations

Configuration table "Switching and controlling"

Function	Explanation	Configuration
Call contact	Provision of this function on this device. Switching point that is activated depending on an incoming call.	<p>Important: If this function of another device is not displayed, please check the permission settings.</p> <ul style="list-style-type: none">• Switching point: Selection of the switching point• Switch on: Trigger that activates the switching point (Start of call, Remote signals, Conversation begins, Conversation ends, Call waiting, Manual)• Switch off: Trigger that deactivates the switching point (Start of call, Conversation begins, Conversation ends, Call waiting, Manual, Time controlled: 0.4 s ... 2 h)• Note: The same trigger is not selectable for "Switch on" and "Switch off".• Options:<ul style="list-style-type: none">- Incoming calls: Function responds to incoming calls- Outgoing calls: Function responds to outgoing calls- Only for door calls: Function is only active for calls from a door station- Invert: Change of the function state of the switching point: (ON becomes OFF / OFF becomes ON)• ON: The function is active for this device• OFF: The function cannot be executed for this device.
Call redirection	Provision of this function on this device.	<ul style="list-style-type: none">• Label: Change of the displayed name of the function (e.g. Floor entrance (Call redirection)) in the Access system for configuration on other devices (e.g. for remote triggering).• ON: The function is active for this device• OFF: The function cannot be executed for this device.

Configuration table "Switching and controlling"

Function	Explanation	Configuration
Door light	<p>Provision of this function on this device. Standard system status: Local switching contact "A3" configured on this device; switching time: 1 minute; option "Retrigger switching output" is active..</p>	<ul style="list-style-type: none"> • Label: Change of the displayed name in the system (e.g. Storey door (Door Light)) • Switching contact: <ul style="list-style-type: none"> - Local switching contact: The switching contact is located on this device or on the Access power supply (ANG ...) - Other switching contact: The switching contact is located on another device • Output: Selectable switching contact. This function can only be assigned to a non-configured output. • Time: Time how long the switching contact remains switched (Manual (Toggle/pushbutton operation) / 0.4 s / 1-59 s / 1-10 min / 15-20-...-55 min / 1-2 h) • Options: <ul style="list-style-type: none"> - Switching output inverted: If this option is active, the idle state and working state of the switching output are exchanged (ON becomes OFF / OFF becomes ON) - Retrigger switching output: The switching duration is extended by the configured time each time the button is pressed again. • ON: The function is active for this device • OFF: The function cannot be executed for this device.
Doormatic	<p>Provision of this function (door-related Doormatic) on this device. If the Doormatic function is activated, a door opener is automatically triggered according to the configuration when a door call is made. A button/tile or an input contact on this or another device can be configured to activate and deactivate the Doormatic function. The Doormatic function can also be controlled via a time profile.</p>	<ul style="list-style-type: none"> • Label: Change to the displayed name in the system (e.g. storey entrance doormatic) in the Access system for configuration on other devices (e.g. for remote triggering). • Open after: Input for the time in seconds for executing the function. Configuration range: 1 - 10 seconds. • Switching: Selection of the door opener (door opener or door opener 2) to be triggered by the doormatic function. • ON: The function can be executed for this device. • OFF: The function cannot be executed for this device.

7 Configure devices

Door stations

Configuration table "Switching and controlling"

Function	Explanation	Configuration
Door Opener / Door Opener 2	Provision of this function on this device. Standard system status: Local switching contact "A1" configured on this device; switching time: 3 seconds; function "Retrigger switching output" is active. Door opener 2 is not preconfigured. A button/tile or an input contact on this or another device can be configured to trigger the "Door Opener 2" function.	<ul style="list-style-type: none"> • Label: Change of the displayed name in the system (e.g. Storey door (Door opener) or Storey door (Door opener 2)) • Switching contact: <ul style="list-style-type: none"> - Local switching contact: The switching contact is located on this device or on the Access power supply (ANG ...) - Other switching contact: The switching contact is located on another device • Output: Selectable switching contact. This function can only be assigned to a non-configured output. • Time: Time how long the switching contact remains switched (Manual (Toggle/pushbutton operation) / 0.4 s / 1-59 s / 1-10 min / 15-20-...-55 min / 1-2 h) • Options: <ul style="list-style-type: none"> - Switching output inverted: If this option is active, the idle state and working state of the switching output are exchanged (ON becomes OFF / OFF becomes ON) - Retrigger switching output: The switching duration is extended by the configured time each time the button is pressed again. • Door call: Door opener terminates call: <ul style="list-style-type: none"> - If this option is active, the door call/door conversation is ended when the door opener is actuated. - If this option is not active, the door call/door conversation is not ended when the door opener is actuated. • Door opener applies to (only for Door opener 2): Selection of all devices authorized for this purpose. Note: No groups can be entered. All devices must be selected separately. • ON: The function is active for this device • OFF: The function cannot be executed for this device.
Video surveillance	Provision of this function on this device. If the function is active, this device can be configured for camera observation on a device.	<ul style="list-style-type: none"> • Label: Change of the displayed name in the system (e.g. Floor entrance (Video surveillance)) in the Access system for configuration on other devices (e.g. for remote triggering). • ON: The function is active for this device • OFF: The function cannot be executed for this device.

8 Adding a member to the group

Group members

- In the “Members” area, all devices assigned to this group are displayed and you can add or remove additional devices to the group.
- As long as no devices have been selected for the group and the selection has been saved, this is indicated by a yellow dot in the page tab and a yellow warning triangle in the header of the page.

Configuration table “Group”

Function	Explanation	Configuration
Add	Adding a member to the group	A mouse click on “Add” opens a selection list with selectable devices for this group. Select the desired device from the open list by clicking on it with the mouse. Each device must be selected individually.
Delete (dust bin symbol)	Removing a selected member from the group	Select the device in the “Members” list with a mouse click and then remove it with a mouse click on the dust bin symbol. Removed devices are immediately selectable again without caching with “Add”.

9 Final assignments

Carry out a function check

Procedure

Carry out a complete function test of the Access system with all devices and all set up functions (Door call, door dialling, door release, internal call, external call, contacts, phone-books etc.)

Handing over the Access system to the customer

Procedure

- 1** Carry out a system backup of the Access system.
- 2** Hand over all files (system backup, licences etc...), the system documents and all changed access data to the customer/operator/system administrator.
- 3** After transferring, delete all commissioning files from your commissioning laptop.
- 4** Instruct the customer/system administrator in the Access system and document the system instruction.
- 5** Hand over the Access system to the customer and document the system handover.

6 Notify the customer/operator/system administrator that he should assign new secure access passwords after system handover, which should not be known to you.

User access and passwords

The server operating system is delivered with default passwords. Assign new and secure passwords and keep these in a safe place. Forgotten passwords of the Access system software and the server operating system cannot be restored and the server operating system would have to be reinstalled and commissioned. For more information, see page 109.

All passwords are the responsibility of the installer/operator/customer.

10 Optional administration functions

Log

This area contains all logged changes to the Access system made via the administration interface. You will receive the current status each time you call up the system or click on the "Reload" icon.

10 Optional administration functions

User status

This area contains the status of all communication objects created in the Access system (groups, door stations, indoor devices, external devices and software clients).

Status messages

Status messages	Status colour	Explanation
Ready	green	Communication object is ready and accessible in the Access system
Busy	red	Communication object is conducting a call; the "Destination number" column contains the number of the remote terminal
DND (Do Not Disturb)	red	The "Do not disturb" (call barring) function is active. The communication object cannot be reached
Error	red	There is a connection error or an error on the communication object itself
Device configured	orange	The Access configuration was successfully transferred to the communication object
Offline	grey	Communication object is not logged on to the Access system or the connection is interrupted
Calls	red	Communication object has started a call; the "Destination number" column contains the destination number
Waiting	orange	The SIP registration process has not yet been completed
Is called	red	Communication object is called; in the column "destination number" the number of the caller is displayed

Administrator / Password

- In the Administrator menu, you can change the description or the password required for logging on to the Access system in the preconfigured user account.
- The Administrator menu can be opened via the project structure or in the header area via the user account button.

Important!

- Several administrator accounts can be created with different access data in the Access system management.
- All administrator accounts have equal rights and have full access to the entire system management (same roles, in same client).

Configuration table "General"

Parameters	Explanation
Name	Name of the user account within the Access system administration (e.g. Administrator). The name can be freely assigned.
Description	Short description (e.g. System Main-Admin)
User name	Unchangeable information field that contains the user name of the user account for the system login.
Password	<ul style="list-style-type: none">• The password is required for logging on to the Access system administration.• The password generated by the system can be freely changed. The new password and the password repetition must be entered for a password change.• "Save" is only possible if both password entries are equal.• Always issue lengthy secure passwords (including upper and lower case letters, numbers and symbols).

Standard login data (after initial setup)

User	Password *
admin	

* Please enter a secure password during the initial setup.

Backup/Restore

In the "Backup/Restore" menu, you save the Access system's system configuration or restore it with a backup file.

Remarks

- This function enables the system configuration to be backed up and restored from Access Professional 6.1 or later.
- The following components of the system configuration are not backed up and cannot be restored:
 - Initial setup configuration (network, time zone, password for logging on to the Access system management)
 - Configuration changes of the server operating system

Backup

In this menu you backup the system configuration and create a backup file.

Procedure

- 1** In the navigation area, click on the "System maintenance" menu.
- 2** The "System maintenance" menu opens up.
- 3** Click in the opened "System maintenance" menu on "Backup/Restore".
- 4** The "Backup/Restore" page opens up in the content area.
- 5** In the "Backup" area, click on "Create".
- 6** The system backup is carried out. The process can take some minutes.

Remarks

- The file export is executed as a download and confirmed directly in the web browser.
- The backup file is located in the area pre-set by you as the default storage location in the web browser (e.g. Downloads).
- The name of the backup file contains the date.

10 Optional administration functions

Backup/Restore

Restore

In this menu you restore the configuration of an Access system with a backup file.

Important!

- During a system restore, the Access system is non-operational for several minutes.
- All system statuses set by users are reset after a restart (e.g. activated Doormatic is deactivated, call redirection set-ups are deactivated, switching outputs are returned to their configured idle status etc.).
- Please plan a suitable time window outside the main operating time of the Access system. Ensure that all affected users are informed of the planned interruption of operation.

Procedure

- 1** In the navigation area, click on the "System maintenance" menu.
- 2** The "System maintenance" menu opens up.
- 3** Click in the opened "System maintenance" menu on "Backup/Restore".
- 4** The "Backup/Restore" page opens up in the content area.
- 5** In the "Restore" area, click in the "Drag your backup file here or click for selection" field.
- 6** The file manager (Explorer) opens.
- 7** In the file manager, navigate to the location of the backup file to select it.
- 8** The file name of the selected file is displayed in the "Uploaded file" field.
- 9** Click on "Restore".
- 10** The backup is imported. The process can take some minutes.
- 11** Successful completion of the system restoration is confirmed with a message.
- 12** Check all the basic parameters in full, carry out any corrections and save them.

Notes on system recovery

- For security reasons, the Siedle app can only be operated after an Access system has been restored if the installed Siedle app matches the registration status on the local Access system and the Siedle server in the cloud and no changes have occurred (e.g. replacement of the smartphone, re-registration due to a new installation, etc.). Otherwise, the Siedle app must be re-registered with a new QR code.
- Due to changed database structures, it is not possible to transfer data from system backups of the previous Access system versions 1–4 to Siedle Access Professional from version 5 or newer!

11 As-delivered status (Server)

Call up initial setup	see page 12
IP address of the Access Server	192.168.1.1
Subnet mask	255.255.255.0

Standard login data – server operating system

User	Password *	SSH login
access	SiedleAccessMain2015	Active

Standard login data (after initial setup)

User	Password *
admin	

* Please enter a secure password during the initial setup.

12 Connecting to external networks – Access Gateway

Access terminals (hardware and software) are also usable in the customer network. For this operating mode, the customer network must be connected to the Access network via the Access Gateway. The Access Gateway securely separates the two networks during operation. An Access Gateway is required for each customer network to be connected.

Important!

- If Access hardware end devices are to be operated in the customer network in addition to Access software clients, these also require the additional DHCP options transmitted by the Access system in the customer network.
- If the customer's own DHCP server is not able to distribute additional DHCP options, the DHCP server service of the Access Gateway must be used in this customer network and the DHCP server service of the customer router/gateway switched off.

Configuring the Access Gateway

- The Access Gateway is not configured in the Access system administration but directly on the administration interface of the Access Gateway.
- Operation of the AGW 671-... requires the Access server V. 6.0.1 as a minimum requirement. If applicable, a software upgrade/update must be carried out.
- Connection to the Access network takes place via the LAN socket "Access". The IP address is issued by DHCP. No other settings are required here.
- Connection to the customer network takes place via the LAN socket "Customer". The IP address is pre-set. In the as-delivered status, a DHCP server is active at the LAN socket "Customer".
- The IP address of the Access server is required for the complete commissioning of the Access Gateway.
- The laptop and Access Gateway must be in the same network. When accessing via the LAN socket "Customer", adjust the network address of the laptop to the IP address range (192.168.240.x).
- SIP services / telephone systems cannot be directly connected over the Access Gateway.
- Alternatively, you can connect the SIP services / telephone systems from the customer network to the Access server by the use of additional hardware (e.g. Session Border Controller – SBC), or if technically possible, you can carry out direct connection in the Access network.

Important!

- Configuration changes are only saved permanently with "Save".
- With every change made, the font colour of the page tab changes to red and "Save" is active.
- After saving, the Access Gateway must be restarted.
- A device restart is possible on the same page or via the dashboard.

Procedure

- 1 Connect the laptop to the LAN socket "Customer" of the Access Gateway.
- 2 Open a browser and enter the IP address "192.168.240.1".
- 3 The login window will open up.
- 4 Enter password "admin".
- 5 Configure the Access Gateway.

12 Connecting to external networks – Access Gateway

Dashboard

After each login to the Access Gateway, the administration interface opens with the dashboard.

General

The “General” area displays information and status about the Access Gateway.

Display field	Explanation
AGW system version	Installed software version and build number of the Access Gateway.
AGW service	Connection status between Access Gateway and Access server
IP address Access server	IP address of the Access server to which this Access Gateway is connected.
Access system version	Installed software version and build number of Access Professional on the Access server.

Device list

In the “Device list” area, all communication objects operated at the Access Gateway (door stations, indoor devices, software clients / apps, third-party devices) and their status are displayed.

Display field	Explanation
Status (circle icon)	Status of the communication object (see status colours).
Call number	Call number of the communication object in the Access system.
IP address	IP address of the communication object.
Device type	Device type of the communication object.

Status colour	Explanation
Green	Ready: Communication object is ready and reachable.
Grey	Offline: Communication object is not registered on the Access system or the connection is interrupted.

Functions

The “Functions” area displays all available functions of the Access Gateway.

Function	Explanation
Support informations	Provides important information for the support case for download (system configuration and log files).
Change password	Password change dialogue for access to the administration interface of the Access Gateway.
Log off	Performs a logoff of the user from the administration interface of the Access Gateway.
Restart – All end devices	Performs a restart of all Siedle Access hardware end devices. The Access server, the Access software clients, the Siedle App or external devices remain in operation unchanged.
Restart – Services	Performs a restart of the gateway services (software).
Restart - Hardware	Performs a complete restart of the Access Gateway (hardware + software).

Basic parameters

In the “Basic parameters” menu, you configure the necessary operating parameters for operation with the Access server.

Configuration table “Basic parameters”

Parameters	Explanation	Configuration
IP address Access server	IPv4 address of the Access server with which this Access Gateway is to be operated.	IPv4: e.g. 192.168.178.1
Compatibility mode	Option, with which system version of the Access server the Access Gateway is to be operated: <ul style="list-style-type: none">• “Compatibility mode” option is set: An Access system version from version 6.0.1 is installed on the Access server.• “Compatibility mode” option is not set: An Access system version with version 5.x.x is installed on the Access server.	–

12 Connecting to external networks – Access Gateway

Network

- In the “Network” menu you configure all the network interfaces and operating parameters required for the network connection of the Access Gateway.
- The IP address assignment for Siedle door controllers and indoor units (ATLC/AHF/AHFV/AHT/AHTV/AVP...) is always carried out via DHCP.
- Door stations, indoor devices, software clients from Siedle and the Access Gateway can currently only be used in IPv4 operation.
- The administration interface of the Access Gateway can be accessed via any network interface.

DNS (Domain Name System)

- In the “DNS (Domain Name System)” area, the central configuration for the DNS server(s) for all network interfaces of the Access Gateway is carried out.
- The DNS supply can be configured either automatically (via DHCP) or manually.
- A DNS server address can only be configured manually if the option “Obtain DNS server address automatically” is not set.
- Manually configured DNS server address(es) are deleted if the option “Obtain DNS server address automatically” is set.

Configuration table “DNS (Domain Name System)”

Parameters	Explanation	Configuration
DNS server	<p>Option how to configure the DNS:</p> <ul style="list-style-type: none">• Option “Obtain DNS server address automatically” is set: The DNS configuration is done automatically via DHCP.• Option “Obtain DNS server address automatically” is not set: The DNS configuration is done manually. <p>DNS servers assigned via DHCP are marked with “(dhcp)” behind the displayed IP address.</p>	IP address of the DNS server (IPv4: e.g. 192.168.178.1)

Network adapter

- In the “Network adapter” area, the IPv4 configuration of the respective network adapter is carried out.
- Each detected network adapter is displayed separately.
- For network adapters with an active network connection, the status display changes from yellow to green.
- Ensure that you have selected the correct network interface during configuration.

Configuration table “Network adapter”

Parameters	Explanation	Configuration
Name	Freely selectable naming of the network interface. The system assigned name is displayed beside the input field (e.g. “ens192”).	e.g. Access network
IP configuration	Option how the IP configuration for this network interface is done: <ul style="list-style-type: none">• “Fixed IP” option is set: The IP configuration of this network adapter is done manually.• “IP from DHCP” option is set: The network adapter obtains the complete IP configuration from the network through a DHCP server.• “Not configured” option is set: This network adapter is not configured.	e.g. “IP from DHCP”
IP address	IPv4 address of this network adapter	IPv4: e.g. 192.168.178.100
Subnet mask	Subnet mask of the network to which this network adapter is connected.	IPv4: e.g. 255.255.255.0
Default gateway	IP address of the default gateway of the network to which this network adapter is connected. If you want the Access system to be accessible via the Internet or other networks (e.g. Siedle app) and not only in island mode, you must enter the correct IP address for the default gateway or router .	IPv4: e.g. 192.168.178.254

12 Connecting to external networks – Access Gateway

DHCP server

- With this option, the DHCP configuration (IPv4) of the associated network adapter is carried out.
- A separate DHCP server can be configured for each network adapter.
- This option is only configurable if the option “Static IP” is selected for IP configuration and the option “For this network adapter” is set.
- Ensure that you have selected the correct network adapter.

Configuration table “Network adapter”

Parameters	Explanation	Configuration
DHCP server	Option whether the Access Gateway may assign IP addresses in the network as DHCP server: <ul style="list-style-type: none">• “Start for this network interface” option is set: The Access Gateway assigns the IP addresses within the network.• “Start for this network interface” option is not set: Another DHCP server in the network assigns the IP addresses or all network clients are configured manually.	e.g. option is set
IP pool, start	First IP address of an IP address range (IPv4) that may be assigned within the network via DHCP.	IPv4: e.g. 192.168.178.150
IP pool, end	Last IP address of an IP address range (IPv4) that may be assigned by DHCP within the network.	IPv4: e.g. 192.168.178.200
DHCP	<ul style="list-style-type: none">• Extended configuration area for configuring the DHCP server.• An automatic adjustment is always made for the proper operation of the Access end devices operated on the Access Gateway.• Please check the settings made completely.	–

DHCP – Extended configuration area (DHCP server)

- The extended configuration area can be called up via the “Options” button.
- In this area, a detailed configuration of the DHCP server is possible.

General

- In this area, the previous configuration of the network interface is displayed for information.
- The IP pool can be adjusted if necessary without leaving the extended configuration area.

Configuration table “General”

Parameters	Explanation	Configuration
IP address	Not changeable: IPv4 address of this network adapter	IPv4: e.g. 192.168.178.100
Subnet mask	Not changeable: Subnet mask of the network to which this network adapter is connected.	IPv4: e.g. 255.255.255.0
IP pool, start	First IP address of an IP address range (IPv4) that may be assigned within the network via DHCP.	IPv4: e.g. 192.168.178.150
IP pool, end	Last IP address of an IP address range (IPv4) that may be assigned by DHCP within the network.	IPv4: e.g. 192.168.178.200

Options

- In this area, the DHCP options can be configured.
- DHCP options can be changed, activated or deactivated.
- Default values for DHCP options can be restored with a mouse click in the event of a misconfiguration.

Configuration table “Options”

Function	Explanation	Procedure
Change option	Allows you to change the value of a DHCP option.	1 Select entry in the listing. 2 Change “Value”. 3 Execute “Apply” (tick symbol).
Restore default value	Allows you to restore the default value of a manually changed DHCP option.	1 Select entry in the listing. 2 Execute “Default value” (magic wand symbol). 3 Execute “Apply” (tick symbol).
Activate/Deactivate option	Allows you to activate/deactivate a DHCP option.	1 Select entry in the listing. 2 Set/remove option from status “Activate option”. 3 Execute “Apply” (tick symbol).

12 Connecting to external networks – Access Gateway

Leases

- In this area, all assigned IP addresses are displayed individually.
- Each IP address (temporarily) assigned to a device can be permanently reserved and edited for this device.
- In future, a reserved IP address will only be assigned to this device and is no longer available for other devices.
- Reservation is only possible within the IP address range (subnet) used and should be done outside the lease range.
- If a reserved IP address is no longer required, it is available again for all devices by releasing it.

Configuration table "Leases"

Function	Explanation	Procedure
Release	Releases a reserved IP address again.	1 Select entry in the listing. 2 Execute "Release".
Reserve	Reserves an IP address assigned to a device permanently for this device.	1 Select entry in the listing. 2 Execute "Reserve".

Reservations

- In this area, IP address reservations for devices can be configured manually.
- For an IP address reservation, the MAC address of the device and the IP address to be reserved must be known.
- Each manually assigned reservation can be deleted again at any time if required.
- Deleting a reservation is always possible in the “Reservations” menu and possible in the “Leases” menu if the reservation is within a lease range.

Configuration table “Reservations”

Function	Explanation	Procedure
New	Enables configuration of an IP address to be reserved.	1 Execute “New”. 2 Enter “MAC address” and “IP address”. 3 Execute “Apply” (tick symbol).
Delete	Deletes a manually configured reservation.	1 Select entry in the listing. 2 Execute “Delete”.

12 Connecting to external networks – Access Gateway

PABX gateway

- A PABX gateway enables the connection of the Access system with a SIP-enabled remote station (e.g. telephone system, VoIP connection) with a SIP voice channel (connection) via an IP-based network.
- Configuration parameters (e.g. account, password, ...) are partly given by the remote station (e.g. VoIP PABX).
- The systems are connected in the same way as a SIP user account with given login data.

Accounts

All configured PABX gateways are displayed individually in this area.

Configuration table "Accounts"

Function	Explanation	Procedure
New	Setting up an account for a PABX gateway.	<ol style="list-style-type: none">1 Execute "New".2 Configure the account of the PABX gateway.3 Execute "Apply".
Edit	Adjustment of a configured account.	<ol style="list-style-type: none">1 Select entry in the listing.2 Execute "Edit".3 Perform configuration change.4 Execute "Apply".
Delete (dust bin symbol)	Deletion of a configured account.	<ol style="list-style-type: none">1 Select entry in the listing.2 Execute delete.

Configuration table "Accounts"

Parameters	Explanation	Configuration
Name	<ul style="list-style-type: none">• Name for the administration within the Access system (e.g. External telephony).• The name can be freely assigned and is displayed within the Access system administration (e.g. Assignment of a PABX gateway in the device configuration of a PABX phone).	–
Account	Default SIP user name (SIP ID, SIP account name or phone number) of the SIP user account.	e.g. [Call number incl. complete area code]
Registrar	IPv4 address or DNS name of the remote station (e.g. IPv4: 192.168.178.100 or DNS names: voipgate.de).	IPv4: e.g. 192.168.178.100
Port	<ul style="list-style-type: none">• Configurable port for negotiating the SIP communication parameters of the PABX connection.• The selected port must also be configured in the remote station.• Possible input range: 1–65535.• Standard port: 5060 (SIP)	e.g. 5060
Password	Password for the SIP user account.	[Password]
Repeat	Confirmation of the entered password.	[Password]

Index

Access device protocol	10	Connecting to external networks	113	Optional administration functions	107
Access Gateway	113	Contents	2	Ordering Access licences	28
Access in-house telephone software	79	Creating a project	34, 36	PABX gateway	52
Access server variant	7	Creating and configuring folders/subfolders	36	PABX phone	72
Access Service Center	2	CTI function	78, 83	Password security	3
Access system overview	6	Dashboard (start page)	18, 112	Permissions	34
Access system version – Important changes	5	Device types and recommended configuration order	47	Recommended commissioning sequence	9
Access to the system	14	Device-specific settings	11	Recommended configuration order	47
Access software concierge	79	Digital video decoupling	31, 32	Safety remarks	3
Accessing the Access system	112	Directory	46	Saving the protocol	18
Adding a member to the group	105	Door station (ATLC)	95	Server	7
Administration graphic user interfaces	15	Door video forwarding	84	Servicing	2
Administrator / Password	109, 112	External devices	72	Setting up the Access system	14
Advanced Concierge video functions	84	Final assignments	106	Set-up of building automation in AVP with KNX (Facility Pilot Server)	55
AHF/AHFV 870-...	60	Function modules	30	Siedle Access device protocol	10
AHT/AHTV 870-...	60	Group	38	Siedle app	87
ASC 170-...	79	Handing over the Access system to the customer	106	SIP telephone	72
As-delivered status (Server)	112	Important changes: Access system version	5	SIP Trunk	49
ASHT 170-...	79	Indoor devices	60	Software client	79
ATLC 670-...	95	Installation and operating conditions	4	Support informations	18
AVP 670-...	60	IP camera	57	Switching & signalling with the Siedle app	87
Backup/Restore	110	JUNG Panel (TKM client)	72	System overview	6
Basic parameters	19	KNX Gateway / KNX group addresses (switching points)	55	Time profile	41
Building automation URL (KNX)	69	LED status display (Button feedback)	49	TKM client	72
Call number plans	33	Licences	28	User interface language	11, 14
Carry out a function check	106	Log	107	User name	7
Changing the password	7, 109, 112	Log in	14, 112	User status	108
Commissioning – Access system	8	MAC address label	10	Using the MAC address label	10
Commissioning possibilities	11	Menu structure Access Professional	17	Voltage mode at output A1	100
Commissioning requirements	8	Navigation	15		
Concierge camera	84	Navigation area	16		
Configure devices	47	Network settings	21		
Configuring the Access video panel (AVP with KNX)	60	New in this version	5		
Connecting and switching on the server hardware	14				

SSS SIEDLE

S. Siedle & Söhne
Telefon- und Telegrafengeräte OHG

Postfach 1155
78113 Furtwangen
Bregstraße 1
78120 Furtwangen

Telefon +49 7723 63-0
Telefax +49 7723 63-300
www.siedle.de
info@siedle.de

© 2023/07.23
Printed in Germany
Best. Nr. 210012089-01 EN