

plug+play

System Manual  
In-Home bus: Audio  
Issue 2021

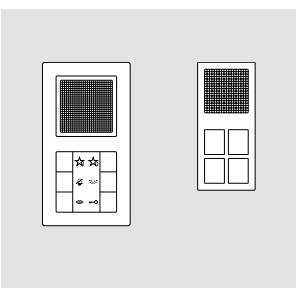
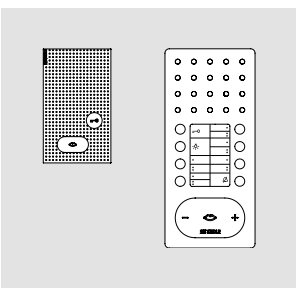
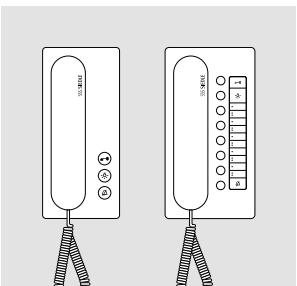

SIEDLE Systemtechnik  
In-Home

# Contents

<b>1 In-Home bus: Audio</b>	
System description	3
<b>2 Siedle Systemtechnik</b>	
Jung indoor stations	3
<b>3 Safety remarks</b>	
Danger	3
<b>4 Configuration, conductor lengths</b>	
User assignment	4
Single line system	5
Single-line system with intercom functions	7
Multiple line system	8
<b>5 In-Home: Audio users</b>	
Door loudspeakers, call buttons	10
Power supply, line rectifiers	12
Switching, control	13
Software, PC interface, DoorCom	14
Bus indoor devices	15
Jung indoor stations	17
Accessories	18
<b>6 Installation</b>	
General information	20
Bus call button module, bus line rectifier	21
Modular Jung indoor station	22
<b>6.1 Installation audio</b>	
Siedle Vario	24
Siedle Compact	26
Siedle custom-fit door loudspeaker	28
Siedle Classic	30
Siedle Steel	32
Siedle Vario with Intercom functions	34
Siedle Vario 2 door stations	36
Multiple line system	38
Call via display call module	40
DoorCom Analog DCA 650-...	42
<b>6.2 Siedle Systemtechnik installation</b>	
Jung audio indoor station	44
Siedle and Jung indoor stations combined	46

<b>7 Programming</b>	
Overview of functions	48
Remarks	52
<b>7.1 Programming – manual</b>	
Activating the bus line rectifier loudspeaker	53
Activating the bus door loudspeaker	54
Activating the indoor devices	55
Activating Jung indoor devices	56
Door call to Siedle Basic	57
Door call to bus telephone	58
Door call to bus handsfree telephone	59
Door call via the storey call button	60
Parallel door call	61
Internal call	62
Dialling the door station	64
Call differentiation of 2 door stations	65
Additional contact on the BSM 650-...	66
Button of a bus telephone on the BSM 650-...	67
Deleting the assignment on the BSM 650-...	68
Parallel door call to BSE 650-...	70
Door call to BSE 650-...	71
Button of a bus telephone on the BSE 650-...	72
Bus secondary signal unit BNS 750-...	73
Call via DRM 612-...	74
Call via COM 611-...	75
Door call to Jung indoor station	76
Parallel door call to Jung indoor station	77
Internal call between Jung indoor stations	78
<b>7.2 Programming – Plug+Play</b>	
Basics	80
Example of a 4-family home	82
Procedure – Example	83
<b>7.3 Programming – with PC</b>	
BPS 650-... and PRI 602-... USB	84

<b>8 Supplementary functions</b>	
Switching and control functions	85
Door release actuation	86
Parallel door call	88
Storey call parallel switching	92
Supplementary contact, radio chime, pilfer safeguard	93
Staircase light/Outside light	94
<b>9 Servicing</b>	
Restart, exchange, operating mode	95
LED displays BNG 650-...	97
Measured values	98
<b>10 Glossary, Index</b>	99

## 1 In-Home bus: Audio

### System description

#### Configuration "Single line"

The In-Home bus: The Audio system comprises a bus installation with a two-core line permitting the connection of up to 31 users, e.g. bus telephones, handsfree bus telephones, door stations or devices for switching and control functions. Technically speaking, one device can occupy more than one user. The line has its own bus line rectifier for central functions such as speech, door release or light switching. The two cores assume the dual functions of power supply and also transmission of audio, switching and control signals. Junction points and branches are admissible at any optional position in the line. In order to connect more than 31 users, several Siedle In-Home: Audio lines can be interconnected.

#### Configuration "Multiple line"

In-Home: Audio "Single line" is restricted to 31 users; In order to connect more than 31 users, up to 15 lines can be coupled together. Each line requires its own bus line rectifier. Junction points and branches are admissible at any optional position in the line.

## 2 Siedle Systemtechnik

### Jung indoor stations

"Siedle Systemtechnik" and the relevant logo are used to describe devices, components or systems which are not manufactured and designed by Siedle but are fitted with Siedle technology. The Systemtechnik logo guarantees technical compatibility with the Siedle system world. Products identified with "Siedle Systemtechnik" may therefore be used without restrictions as components of a Siedle communication system.

#### Jung indoor stations in switch design

Within the framework of a cooperation agreement with the company Jung, Siedle equips Jung indoor stations with "Siedle Systemtechnik". Indoor stations from Jung which bear the Systemtechnik logo on their components, their packaging or the product information, are fully compatible with Siedle technology. They are integrated in this manual as Siedle system components.

**SIEDLE** Systemtechnik  
In-Home

## 3 Safety remarks

### Danger



Mounting, installation and servicing work on electrical devices may only be performed by a suitably qualified electrician. Failure to observe this regulation could result in the risk of serious damage to health or fatal injury due to electric shocks.

- When working at the device, observe the remarks relating to mains cut-off.
  - Operation at an altitude of up to 2000 m above sea level.
  - Observe EN 62368-1!
- In a building installation, an all-pole mains switch with a contact opening of at least 3 mm must be provided. The device must not be exposed to water drops or sprayed water! Sufficient ventilation must be ensured. Pay particular attention to ensure that ventilation slots are not covered.
- Ensure maximum fusing of 16 A for the mains connection in the building installation.
  - When planning large-scale (complex) systems, the distributor space required for the switch panel mounting devices must be taken into consideration in the distributor planning process.
  - No external voltages >30 V AC/DC may be applied to bus users.

#### Devices with 230 V connection

In accordance with DIN VDE 0100 part 410, section 411.1.3 attention must be paid to ensuring a safe separation between system lines and the mains voltage; i.e. system and mains cores must not be permitted to touch! The system line cable (extra-low safety voltage) must be stripped back by the minimum possible.

## 4 Configuration, conductor lengths

User assignment

SIEDLE Systemtechnik

### Devices occupying 1 user

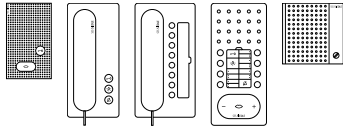

AIB 150-...  
BTS 850-...  
BTC 850-...  
BFC 850-...  
BNS 750-...

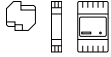

BSE/BEM 650-...  
BSE/BEM 651-...  
BSM 650-...

### Devices occupying 2 users

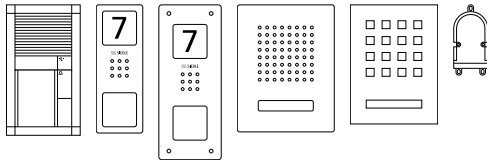

BTLM 650-...  
CA 850-...  
CAU 850-...  
CL A xx B-02  
STL ...  
BTLE 050-...

### Devices with variable user assignment (depending on programming)



DCA 650-...

### Devices occupying no users

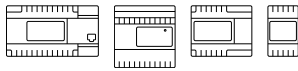

BNG 650-...  
NG 706-30/33-...  
NG 602-...  
TR 603-...



BIM 650-...  
PRI 602-... USB  
BRMA 050-...

### Devices occupying 1 user

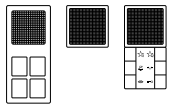

SI 4 A ..  
SI AM ...  
SI AI ...

### Devices occupying no users



SI TM .. 5073  
SI TM .. 5093

## Single line system

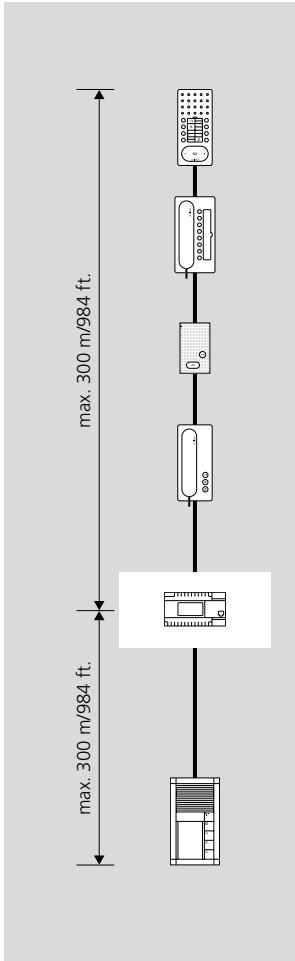

### Configuration of In-Home: Audio

The basic installation of In-Home-Bus: Audio takes place as a single-line system. Within this line, the users are installed on the bus cores. A maximum of 31 users may be connected to one line. Users are classified as devices occupying an address within the bus. If more than 31 users are required, additional lines must be configured. Apart from a few exceptions, all the devices have an assigned address. Up to 15 lines each with 31 users can be configured (in theory a maximum of 465 users).

### Power supply

The nerve centre of any line is the bus line rectifier, which controls the entire function of the system. The bus cores are connected to the bus line rectifier.

### Conductor material

Telecommunication or light current conductors can be used for installation:

J-Y(St)Y	Twisted pair conductors, shielded
CAT	Network cable
A2Y(St)2Y	Buried telecommunication cable
YR	Light current conductor 0.8 mm core diameter

The In-Home bus must be installed on one pair of cores when using J-Y(St)Y, and when using a YR conductor, on two YR cores positioned side by side. Using J-Y(St)Y conductors reduces the likelihood of interference.

### Conductor length

Conductor material J-Y(St)Y or YR conductor with 0.8 mm diameter:

- max. 300 m from the bus line rectifier to the most distant door station
- max. 300 m from the bus line rectifier to the most distant bus telephone.

Conductor material J-Y(St)Y or YR conductor with 0.6 mm diameter:

- max. 150 m from the bus line rectifier to the most distant door station
- max. 150 m from the bus line rectifier to the most distant bus telephone.

### Network cable

Diameter		Conductor length
0.405 mm	AWG 26	80 m
0.511 mm	AWG 24	120 m
0.644 mm	AWG 22	200 m

A maximum of 1500 m of installation cable may be laid within the line.

## 4 Configuration, conductor lengths

### Single line system

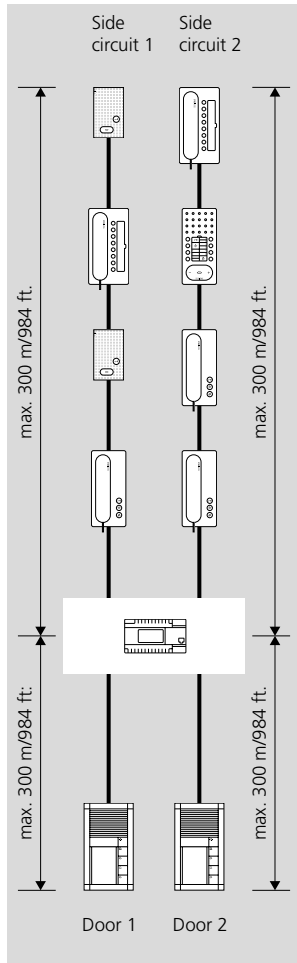

#### Range

Cable material J-Y(St)Y or YR  
0.8 mm

Distribution of the installation in the sub-distribution board:

- Range to door station 1 and door station 2 Each max. 300 m,
- Range to the most distant bus telephone in side circuit 1 max. 300 m,
- Range to the most distant bus telephone in side circuit 2 max. 300 m.

A maximum of 1500 m of installation cable may be laid within the line.

## Single-line system with intercom functions

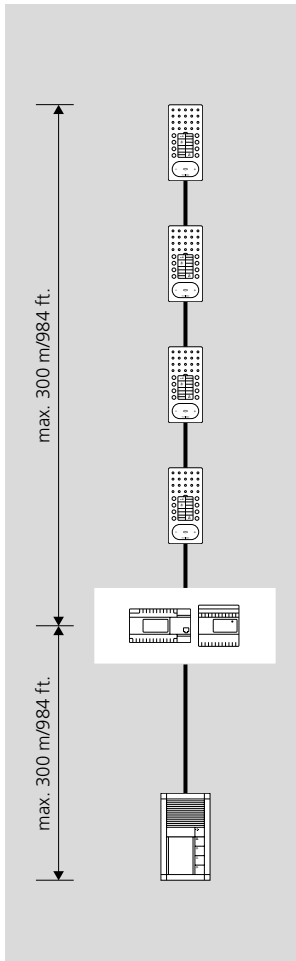

### Configuration with intercom function

Using the handsfree bus telephone BFC 850-..., internal building communication can be supplemented to include additional convenience functions.

- Internal call with callback function
- Automatic call pick-up of internal calls
- Internal group call (max. 8 devices)
- Collective paging announcement (\*only with supplementary supply and accessories)

For the paging announcement intercom function, an accessory is required in each handsfree bus telephone BFC 850-... This permits a direct voltage power supply directly to the handsfree bus telephone.

Using handsfree bus telephones, communication is possible without lifting the receiver. From a handsfree bus telephone, it is possible to call devices both with and without a receiver. Intercom functions are only possible within a line. Door calls have priority over internal calls.

In order to utilize the intercom functions, the system must be programmed at the PC.

### Power supply

The nerve centre of any line is the bus line rectifier, which controls the entire function of the system. The bus cores are connected to the bus line rectifier.

\*) A supplementary power supply using a line rectifier or video line rectifier is only necessary in the case of collective paging announcements or parallel calls with more than two users.

### Conductor material

Telecommunication or light current conductors can be used for installation:

J-Y(St)Y	Twisted pair conductors, shielded
CAT	Network cable
A2Y(St)2Y	Buried telecommunication cable
YR	Light current conductor 0.8 mm core diameter

The In-Home bus must be installed on one pair of cores when using J-Y(St)Y, and when using a YR conductor, on two YR cores positioned side by side. Using J-Y(St)Y conductors reduces the likelihood of interference.

### Conductor length

Conductor material J-Y(St)Y or YR conductor with 0.8 mm diameter:

- max. 300 m from the bus line rectifier to the most distant door station
- max. 300 m from the bus line rectifier to the most distant bus telephone.

Conductor material J-Y(St)Y or YR conductor with 0.6 mm diameter:

- max. 150 m from the bus line rectifier to the most distant door station
- max. 150 m from the bus line rectifier to the most distant bus telephone.

### Network cable

Diameter		Conductor length
0.405 mm	AWG 26	80 m
0.511 mm	AWG 24	120 m
0.644 mm	AWG 22	200 m

A maximum of 1500 m of installation cable may be laid within the line.

# 4 Configuration, conductor lengths

## Multiple line system

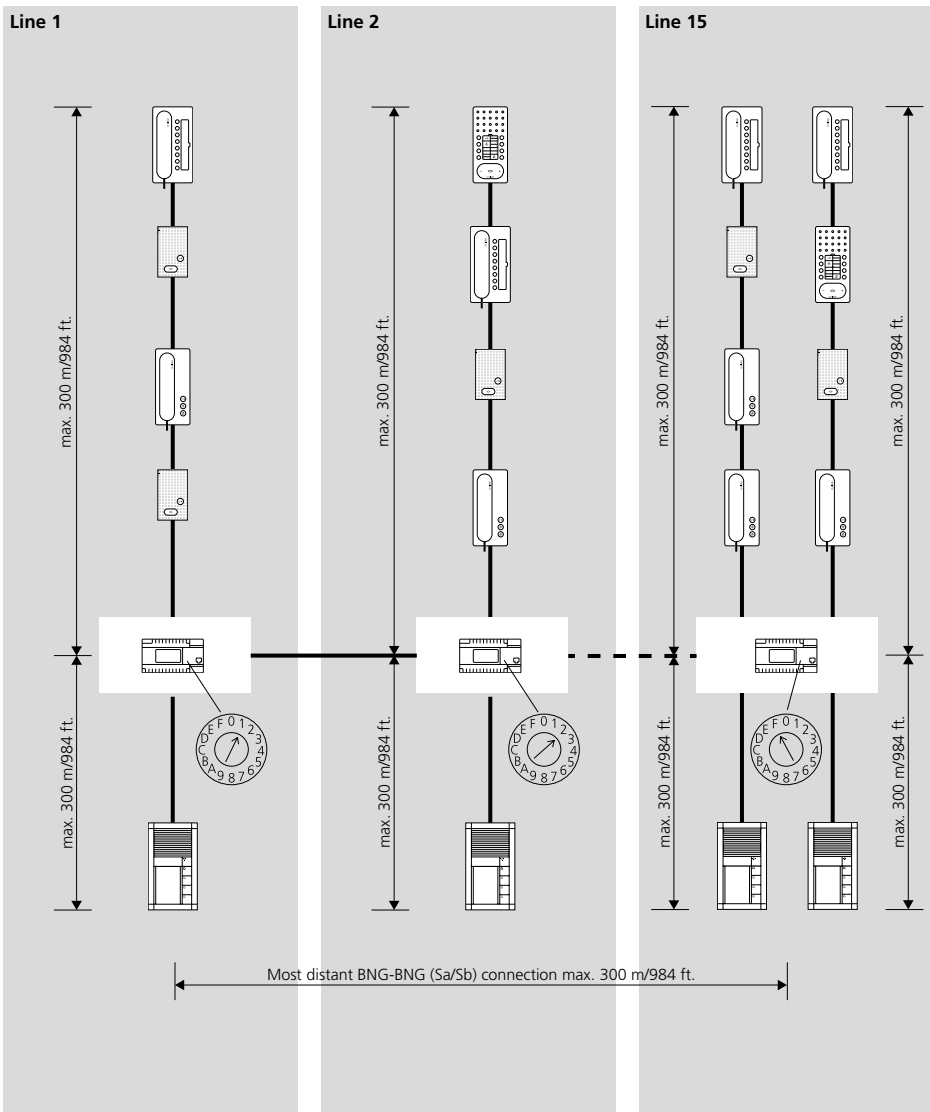



### **Configuration of the multiple line system**

A multiple line system comprises individual lines which are linked together by two cores. The lines are connected at the bus line rectifier using terminals Sa and Sb. In multiple line systems, door calls and control functions are possible from one line to another.

### **Differentiation between line 1 and line 2 ...**

The lines are consecutively numbered with the address switch "Adr." at the bus line rectifier. Up to 15 lines can be connected via the cores Sa and Sb. The bus supply unit accessory ZBVG 650-... must be plugged into one of the bus line rectifiers within the overall system. When installing, ensure that every line is laid in its own cable.

### **Conductor length between the lines**

The admissible conductor lengths within a line are identical to those in a single line system. The conductor length between the bus line rectifiers must also be taken into consideration. This may not be more than 300 m between the most distant bus line rectifiers.

### **Functions applicable across individual lines**

Door calls, selective door dialling and switching and control functions can also be used across individual lines. Internal speech communication and call forwarding between users is only possible within a line.

## 5 In-Home: Audio users

### Door loudspeakers, call buttons

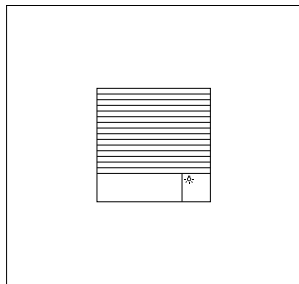

#### BTLM 650-04

Bus door loudspeaker module for In-Home bus. Loudspeaker and microphone integrated, illuminated light button, integrated door release contact (DR) Acoustic acknowledgement on pressing a button, can be activated if required with the BPS 650-... contact load max. 15 V AC, 30 V DC, 2 A, switching time DR fixed at 3 seconds. Acoustic feedback when actuating the call buttons.

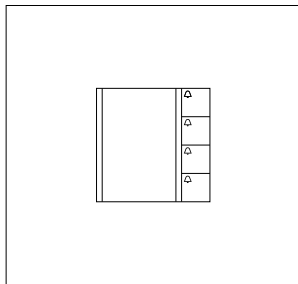

#### BTM 650-01 to -04

Bus call button modules for In-Home bus 1–4 call buttons, integrated LED lighting. Connection by means of ribbon cable to the bus door loudspeaker. Supply to the LED lighting via terminal b and c with 12 V AC, current consumption 20 mA per bus call button module BTM 650-...

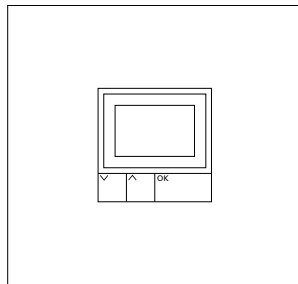

#### DRM 612-02

Display call module as an input device with 4-line display for placing door calls. Indication of names in the display in alphabetical order. The DRM 612-... can also be used in combination with the COM 611-... in order to display the input via the DRM 612-...

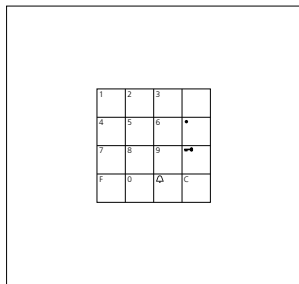

#### COM 611-02

Code lock module as input unit for access control and for making door calls.

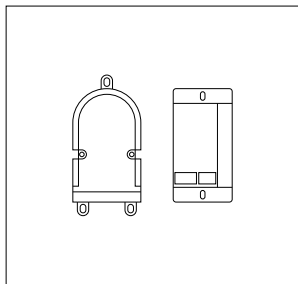

#### BTLE 051-04

Bus custom-fit door loudspeaker with bus call button matrix for installation in the customer's intercom compartments, door constructions, letterboxes, etc. Up to 12 of the customer's call buttons can be directly connected to the BRMA 050-... bus call button matrix.

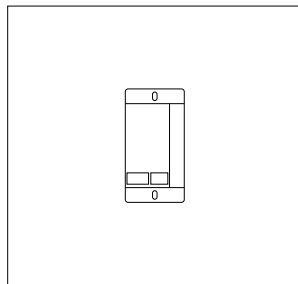

#### BRMA 050-01

Bus call button matrix for connecting 12 on-site call buttons to the BTLE 050-.../ATLE 670-... custom-fit door loudspeaker. Max. 160 call buttons can be connected. However, a bus call button matrix BRMA 050-... is required for each started group of 12 call buttons.

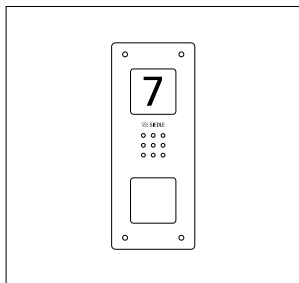

### CAU 850-... E

Siedle Compact audio door station flush mounting, for installation in the In-Home bus. With the functions calling, speech and door release.

Contact type: contact 24 V, 2 A

Protection system: IP 54

Ambient temperature:

-20 °C to +55 °C

Dimensions front panel (mm)

W x H x D: 110 x 273 x 1

Dimensions housing (mm)

W x H x D: 85 x 253 x 48

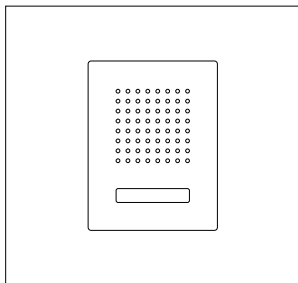

### Siedle Classic

Door station with stainless steel front. Door loudspeaker and illuminated call buttons. Integrated door release contact (TÖ), contact load max. 15 V AC, 30 V DC, 2A, switching time TÖ fixed at 3 seconds. Current consumption for LED lighting of bell buttons, per button 5 mA, 12 V AC.

Acoustic feedback when the call button is pressed.

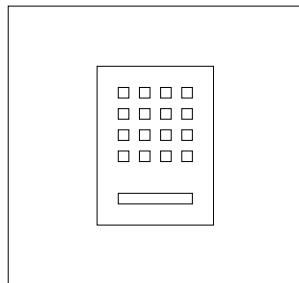

### Siedle Steel

Door station with stainless steel front, door loudspeaker and call buttons. Integrated door release contact (TÖ), contact load max. 15 V AC, 30 V DC, 2 A, switching time TÖ fixed at 3 seconds. Current consumption for LED lighting of bell buttons, per button 3 mA, 12 V AC. Acoustic feedback when the call button is pressed.

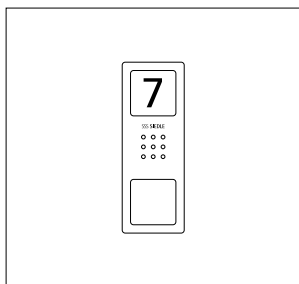

### CA 850-... E

Siedle Compact audio door station, for installation in the In-Home bus or as a replacement device in the Siedle Basic audio set. With the functions calling, speech and door release.

Contact type: contact 24 V, 2 A

Protection system: IP 54

Ambient temperature:

-20 °C to +55 °C

Dimensions (mm) W x H x D:

82 x 226 x 29

## 5 In-Home: Audio users

### Power supply, line rectifiers

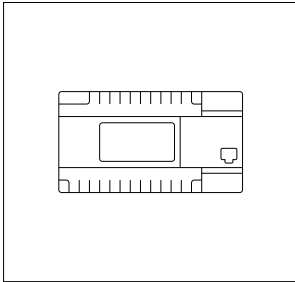

#### **BNG 650-0**

Bus line rectifier in a 9-grid housing.  
Primary: 230 V AC, 50/60 Hz  
Secondary: 12 V AC, 1 A  
Door release contact 15 V AC,  
30 V DC, 2 A, switching time fixed  
at 3 seconds.  
Light contact 15 V AC, 30 V DC,  
2 A, switching time 0.4 seconds,  
capable of being changed with bus  
programming software BPS 650-...

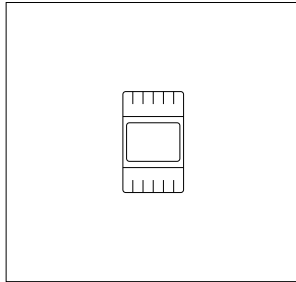

#### **TR 603-0**

Transformer in a 3-grid housing.  
Primary: 230 V AC, 50/60 Hz  
Secondary: 12 V AC, 1.3 A  
Supply to the LED lighting of the bus  
call button module, door release or  
heating for the bus camera.

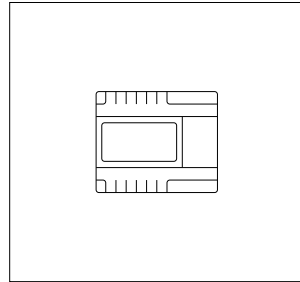

#### **NG 602-01**

Line rectifier in switch panel housing  
for 1+n technology, and for power  
supply to supplementary compo-  
nents. Inclusive function LEDs.  
Operating voltage: 230 V AC,  
+/-10 %, 50/60 Hz  
Operating current: 200 mA  
Output voltage: 23.3 V DC, 12 V AC  
Output current: 0.3 A DC, 1.6 A AC  
Fusing: primary Si1 T 200 mA L,  
secondary side with thermal fuse  
Protection system: IP 20  
Ambient temperature:  
0 °C to +40 °C  
Horizontal pitch (HP): 6  
Dimensions (mm) W x H x D:  
107 x 89 x 60

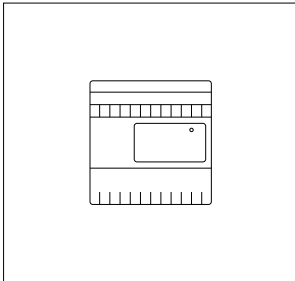

#### **NG 706-30/33-0**

Line rectifier in switch panel housing  
for central supply of Siedle system  
components.

Operating voltage: 230 V AC,  
+/-10 %, 50/60 Hz  
Operating current: 250 mA  
Output voltage: 30 V DC  
Output current: 1.1 A

## Switching, control

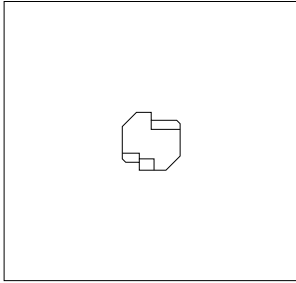

### **BSE 650-01**

Bus switching unit with bistable relay, suitable for mounting in a 70 junction box. Actuation possible via BEM, using the programmable buttons of the system users or in parallel to a door call button.

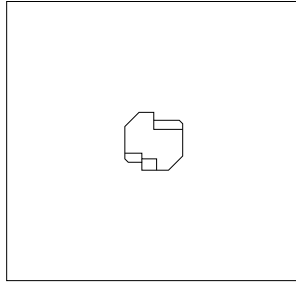

### **BEM 650-02**

Bus input module for mounting in a 70 junction box with an input for tripping switching functions/transmitting messages at the In-Home bus. Actuation possible via potential-free contact or 4–30 V DC, 10 mA.

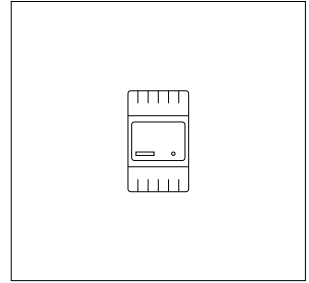

### **BSM 650-02**

Bus switching module in 3-grid housing. 4 integrated relays, each with a potential-free working contact. Actuation via the call buttons of the bus telephones or light button at the door station. Relay functions as a timer between 0.4 seconds and 12 seconds. Max. contact load 15 V AC, 30 V DC, 2 A. 12 V AC supply required, 250 mA.

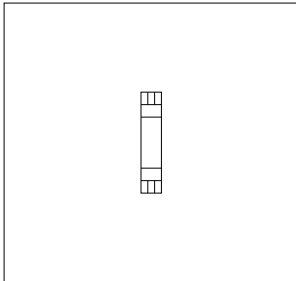

### **BSE 651-0**

Bus switching unit for the top hat rail, with bi-stable relay. For implementing various switching scenarios. Actuation possible via BEM bus input module, the function buttons of the bus telephones (incl. door release button) or the light or call button of a door station.

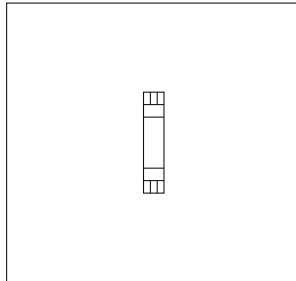

### **BEM 651-0**

Bus input module for the top hat rail. With one input for triggering switching functions or leaving messages on the In-Home bus. Actuation possible via potential-free contact or 4–30 V DC, 10 mA.

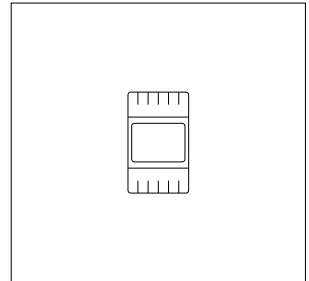

### **BIM 650-02**

Bus interface module in switch panel housing, used for connection between Siedle Vario bus and Siedle In-Home bus. It is always required when a bus door loudspeaker has to be equipped with a COM or DRM in addition to or instead of direct call buttons.

## 5 In-Home: Audio users

Software, PC interface, DoorCom

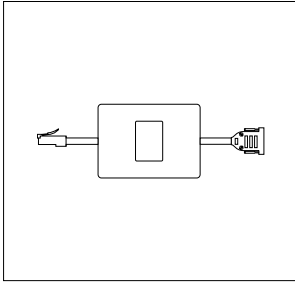

### PRI 602-0

Programming interface for connection of a Windows PC via serial interface to the Vario bus. The Vario bus is programmed using programming software PRS 602-..., provided with the delivery. If the BIM 650-... is additionally used, the In-Home bus can also be programmed.

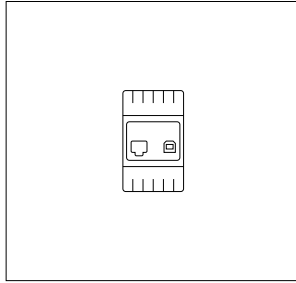

### PRI 602-01 USB

Programming interface for connection of a Windows PC via USB port to the ZBVG 650-... interface. The ZBVG 650-... is plugged into bus line rectifier BNG/BVNG 650-... Commissioning, programming and servicing facility for the In-Home bus using BPS 650-... software.

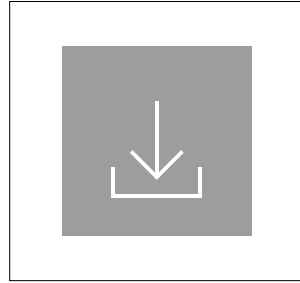

### BPS 650-... from V2.50

Bus programming software for programming In-Home bus systems. For this, the programming interface PRI 602-... is also required in conjunction with a BIM 650-... or the PRI 602-... USB.

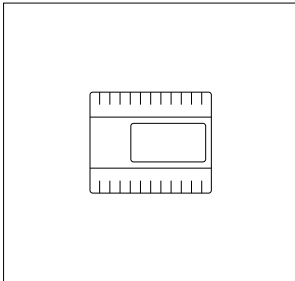

### DCA 650-02

DoorCom-Analog for connection of one or more door stations to an analog PBX extension of a telephone system. Up to 31 call numbers can be stored. The call can be made using bell buttons or the display call module from the door station. Power supply with 12 V AC to terminals b and c, connection to the In-Home: Audio via terminals Ta/Tb.

## Bus indoor devices

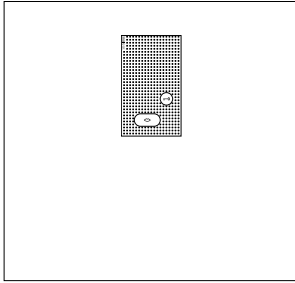

### **AIB 150-01**

Audio indoor station Siedle Basic: Handsfree station for surface mounting.

Entry-level device with all essential functions in the accustomed standard of Siedle quality. Minimized ergonomically optimized design with simple operation, clear symbolism and excellent acoustics.

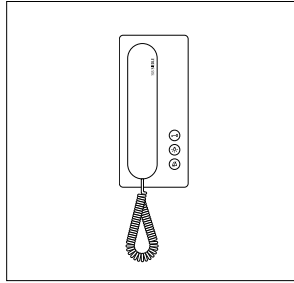

### **BTS 850-02**

Standard bus telephone. Connection at bus cores Ta and Tb.

Functions:

- Calling, speech, door release and storey call
- Door release and light button
- Internal speech communication
- 11 ringtones
- Call and voice volume adjustable in 5 steps
- Muting button for ringtone
- Double assignment of the light button and silencing button possible.
- Integration of ZAR 850-... accessory possible

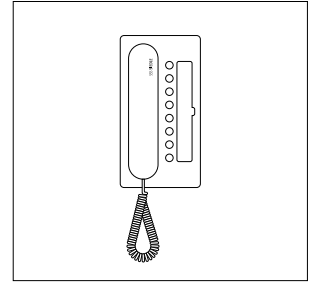

### **BTC 850-02**

Deluxe bus telephone. Connection at bus cores Ta and Tb.

Functions:

- Calling, speech, door release and storey call
- Door release and light button
- Internal speech communication
- 11 ringtones
- Call and speech volume can be changed in 5 steps
- Silencing button for the ringtone
- 7 keys for switching and control functions with double assignment facility
- 7 LEDs under the buttons for display of switching statuses
- Integration of ZAR/ZPS 850-... accessory possible

## 5 In-Home: Audio users

### Bus indoor devices

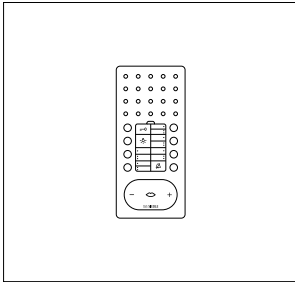

#### **BFC 850-0**

Deluxe handsfree bus telephone intercom. Connection at bus cores Ta and Tb.

Functions:

- Calling, handsfree/simplex communication, door release and storey calls
- Speech/control button
- Door release and light button
- Internal speech communication
- 11 ringtones
- Call and speech volume can be modified in 5 stages
- Muting button for the ringtone
- 7 keys for switching and control functions with double assignment facility
- Additional intercomfunctions possible (from V 4.0)
- Integration of ZARF/ZPSF 850-... accessory possible



Jung indoor stations

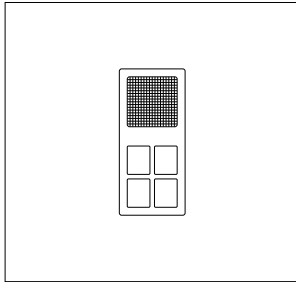

**SI 4 A ..**

Audio indoor station standard  
Audio indoor station design standard  
Calling, speech, door release, light,  
storey call, switching/control func-  
tions and internal communication.

- Polarity reversal-proof 2-wire installation
- Connection for Siedle In-Home bus
- Connection for storey call button
- Call generator with 11 call tone sequences, including chime
- Muting and status display

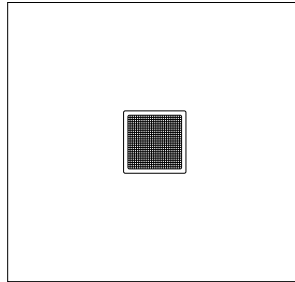

**SI AM ...**

The audio module is the basic module of the modular structured flush mounted indoor station. This is where the Siedle In-Home bus is connected. If no call button module or video module is connected, the audio module functions as a secondary signal unit (bell).

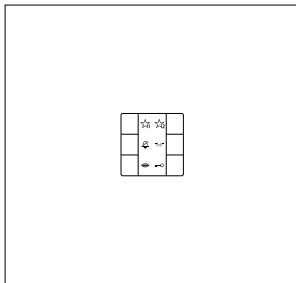

**SI TM .. 5073**

The standard call button module has 5 LEDs for display (e.g. door open) without additional wiring, one ready status using LED and one optical call display by means of a flashing LED at the speech button.

The standard call button module is supplied including inscription film for audio / video and audio connecting cable (red, 220 mm).

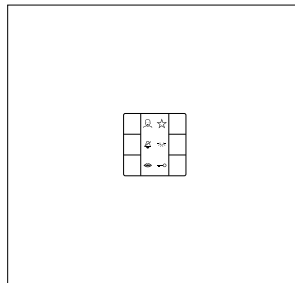

**SI TM .. 5093**

The universal call button module has 5 LEDs for display (e.g. door open) without additional wiring, one ready status using LED and one optical call display by means of a flashing LED at the speech button.

The universal call button module with inscription field capable of illumination is supplied including inscription film for audio / video and audio connecting cable (red, 220 mm).

The universal call button module has one terminal for a supplement-

tary power supply. This is required for operation of a video module, illumination of the inscription field in the universal call button module, and when connecting a second call button module. An additional call button module (standard or universal, max. 2 call button modules per indoor station) can be connected.

## 5 In-Home: Audio users

### Accessories

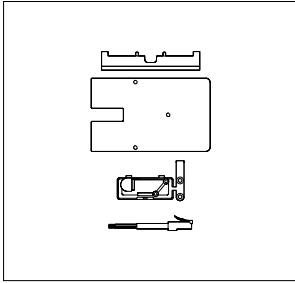

#### ZTS 800-01

Table-top accessory for telephones BTS/BFC 850-... and HTS 811-... for conversion from a wall to a table-top unit. Slip-proof console with 2 rubber feet but without UAE 8(8) junction box.

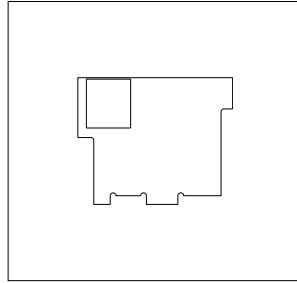

#### ZBVG 650-0

Bus supply unit accessory as a plug-in card for integration in bus line rectifier BNG 650-... or bus video line rectifier BVNG 650-... with 8-pin Western socket for connection of the programming interface PRI 602-... USB.

Is required in systems with more than one line or for programming the in-home bus via a Windows PC and PRI 602-... USB. Only one unit may be installed within the Siedle In-Home bus.

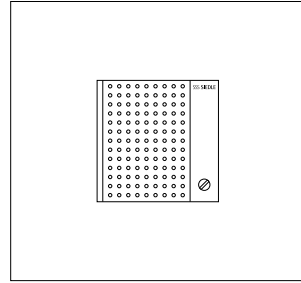

#### BNS 750-02

Bus secondary signal unit, for signalling door and storey door calls in another room or corridor. Connection to In-Home bus: Audio Call volume steplessly adjustable up to max. 86 dB(A). Call differentiation for door calls and storey calls.

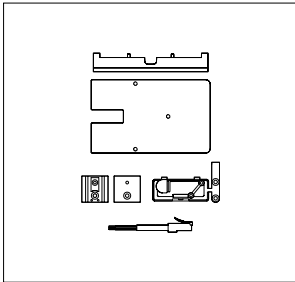

#### ZTC 800-0

Deluxe table-top accessory for the bus telephone BTC 850-... for conversion from a wall to a table top unit. Connection of the table top unit to an 8-pin telecom socket type UAE 8/8(8).

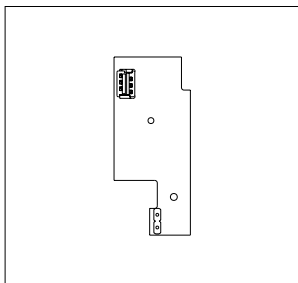

### ZPS 850-0

Parallel switching accessory for integration into deluxe bus telephone BTC 850-... Circuit board for connection of an additional power supply. Required in case of manual programming from the third BTC 850-..., with PC programming from the fifth BTC 850-... Supply 20–30 V DC from NG 602-... or NG 706-30/33-..., current consumption max. 100 mA

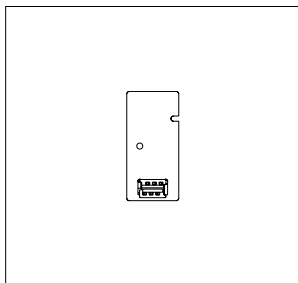

### ZPSF 850-0

Parallel switching accessory for integration into deluxe handsfree bus telephone BFC 850-... Circuit board for connection of an additional power supply. When programming manually, required from the third BFC 850-..., when programming by PC from the fifth BFC 850-... Supply 20–30 V DC from NG 602-... or NG 706-30/33-..., current consumption max. 100 mA. Required for the function parallel door call, collective paging announcement/internal group call to more than 2 bus telephones. When programming with BPS 650-... 4 bus telephones.

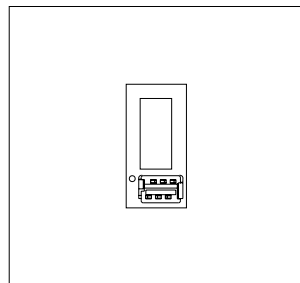

### ZAR 850-0

Interfacing relay accessory for integration into bus telephone BTS/ BTC 850-... Universal switching relay for secondary signal unit, video interfacing or switching relay. Potential-free switching contact max. 15 V AC, 30 V DC, 1 A, switching time 0.4 seconds – 19 minutes Supply via the In-Home bus.

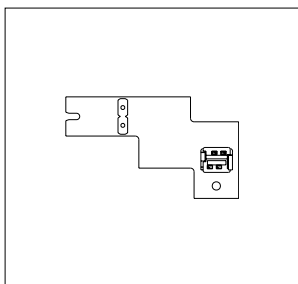

### ZARF 850-0

Handsfree interfacing relay accessory for integration in the handsfree bus telephone BFC 850-... Universal switching relay e.g. for secondary signal unit, video actuation or switching relay. Contact type: Contact 15 V AC, 30 V DC, 2 A. Switching time: 0.4 sec to 19 min programmable using the bus programming software BPS 650-... V2.x

## 6 Installation

### General information

#### Note

As in the as-delivered/de-energized status, the contact position of the bistable relay (contact S1/S1) cannot be defined, the bus supply to the device must be connected beforehand to ensure that the bistable relay functions correctly.

Consumers	Voltage	Current
Door release	12 V AC	appr. 600 mA
Vario bus call button module (BTM 650-01 to -04)	12 V AC	max. 20 mA
Steel button illumination	12 V AC 10–30 V DC	max. 3 mA
Classic button illumination CL ...-01	12 V AC 10–30 V DC	max. 25 mA max. 30 mA
Classic button illumination CL ...-02	12 V AC 10–30 V DC	max. 5 mA

Models	Terminal assignment	Voltage	Current
BNG 650-...	Ta, Tb	27.5 V DC	500 mA
	b, c	12 V AC	1000 mA
NG 602-...	+, -	23.3 V DC	300 mA
	b, c	12 V AC	1600 mA
TR 603-...	b, c	12 V AC	1300 mA
TR 602-...	b, c	12 V AC	2500 mA
NG 706-30/33-...	+, -	30 V AC	1100 mA

#### Terminals

##### AIB 150-...

##### BTS/BTC/BFC 850-...

Ta, Tb In-Home bus: Audio

ERT Storey call button

Optionally

#### Terminals

##### ZAR/ZARF 850-...

S1/S1 Potential-free contact  
15 V AC, 30 V DC, 1 A

## Bus call button module, bus line rectifier

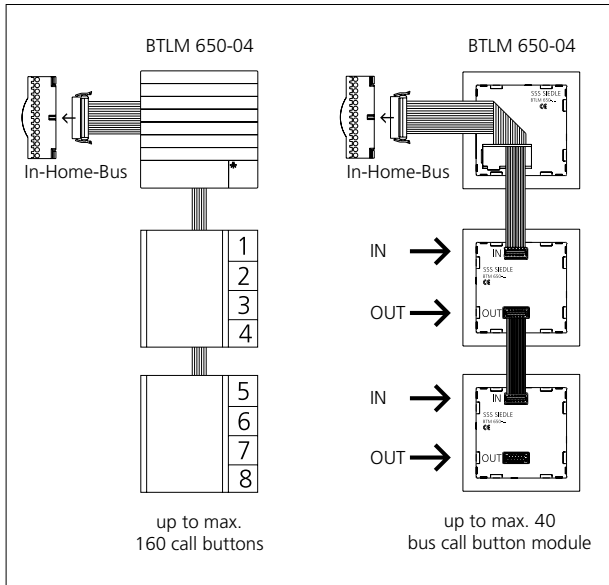

### Bus call button module

Connection of the bus call button modules to the bus door loud-speaker via ribbon cable. The name plate lighting is supplied from the terminal block of the BTLM 650-04. If there are more than 20 illuminated bus call button modules with LED lighting (BTM 650-01, -02, -03, -04), these must be supplied via an additional transformer with 12 V AC if a door release is operated within the system.

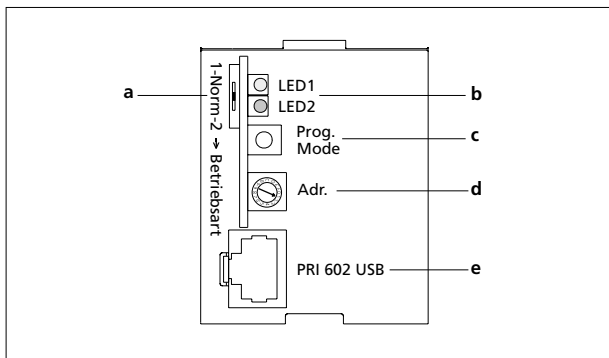

### Bus line rectifier

At bus line rectifier BNG 650-..., the **operating mode selector switch** must be set to Norm in a new system (as-delivered status). If first series bus telephones are used within the line, (e.g. B. BTS/ BTC 750-0), the operating mode switch must be set to 1. For more information, see page 96

Using the **"Adr."** rotary switch, the address is set at the bus line rectifier. In single line systems, this is address 1 in the as-delivered status. This setting does not need to be altered. In multiple line systems, the bus line rectifiers are addressed in consecutive sequence.

- |          |   |   |
|----------|---|---|
| <b>a</b> | 1   | = Reverse compatible (with BSG 650-...) |
|          | Standard  | = Operation as a new system             |
|          | 2   | = Function identical to standard        |
| <b>b</b> | LED 1   | = Operational LED                       |
|          | LED 2   | = Error LED                             |
| <b>c</b> | Button for programming mode ON/OFF.   |   |
| <b>d</b> | Address setting from 1-15 (1-F) required in multiple-line systems.                      |   |
| <b>e</b> | Socket for connection of PRI 602-... USB, only available if ZBVG 650-... is plugged in. |   |

## 6 Installation

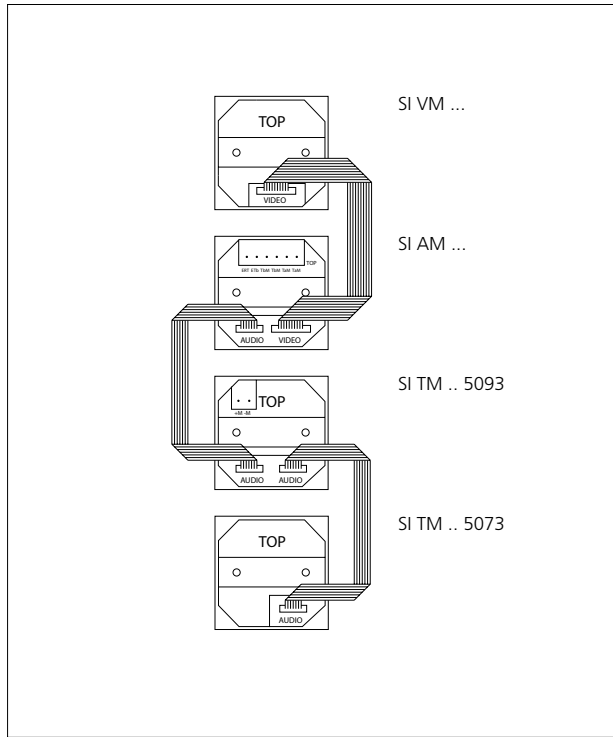

### Modular Jung indoor station









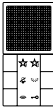

Every module is mounted in a flush-mounting junction box in compliance with DIN 49073. We recommend using a deep junction box for mounting. Mounting takes place using the provided support rings. Mounting can take place in combination or individually – horizontally or vertically.

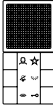
The modules are interconnected using the supplied connecting cables.

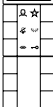
Connection to the In-Home bus takes place at the audio module. The universal call button module has one terminal for a supplementary power supply. This is required for operation of a video module, illumination of the inscription field in the universal call button module, and when connecting a second call button module. An additional call button module (standard or universal, max. 2 call button modules per indoor station) can be connected.

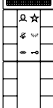
SI AI ... Audio indoor station	Item no.	Item designation
	SI AM ...	Audio module
	SI TM .. 5073	Standard call button module

Audio combinations	Item no.	Item designation
	SI AM ...	Audio module
	SI TM .. 5073	Standard call button module
	SI AM ...	Audio module
	SI TM .. 5093	Universal call button module
	SI AM ...	Audio module
	SI TM .. 5093	Universal call button module
	SI TM .. 5073	Standard call button module
	SI AM ...	Audio module
	SI TM .. 5093	Universal call button module
	SI TM .. 5093	Universal call button module

# 6.1 Installation audio

Siedle Vario

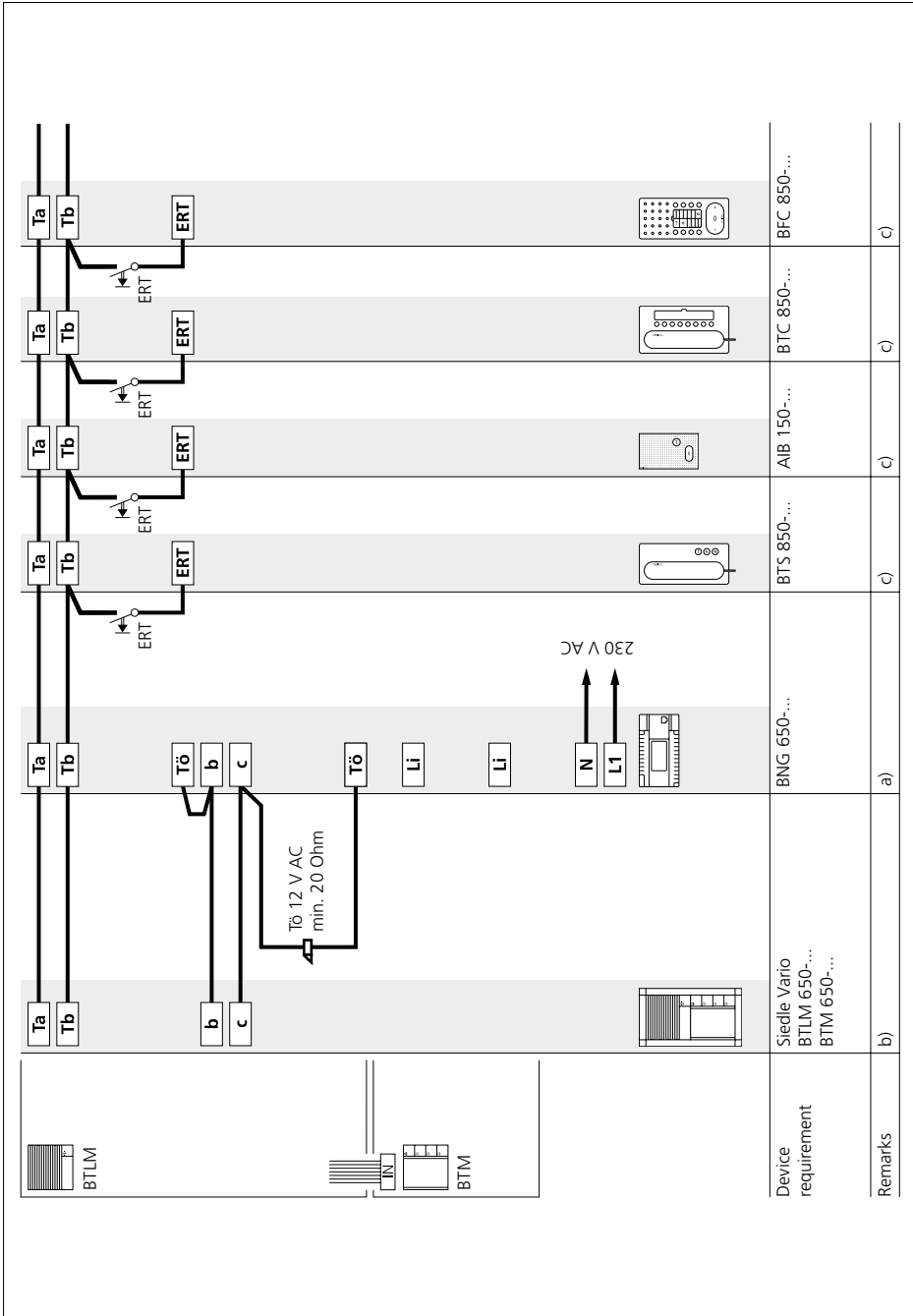



## Siedle Vario

### Functional

Calling and speech between the door station and the connected bus indoor devices.

Other bus telephones are not able to listen in to an existing call. Door release button for the door release function, light button for the light switching function. Connection of a storey call button (ERT) for calling from an apartment door. Ringtones can be selected for calls from the front door, apartment door or internal calls. Connection of additional bus telephones or bus door loudspeakers possible at the In-Home bus without accessories.

### Supplementary functions

• **Internal speech communication** between bus indoor devices is only possible internally within the same line.

• **Switching and control functions** are possible with the bus switching modules BSM/BSE/BEM 650-..., feedback to the deluxe bus indoor devices can be programmed.

• **Bus secondary signal unit** BNS 750-... possible.

For more information, see page 92

• **Parallel door and storey call**

Up to 4 AIB 150-.../BTS/BTC/BFC 850-... devices can be called simultaneously. With the parallel switching accessory in devices BTC/BFC 850-..., the number can be extended to a maximum of 8. Only possible within a line.

For more information, see page 88

• **Selective dialling of the door station** possible via additional free buttons.

### Remarks

**a)** The BNG 650-... is able to supply 1 door release and max. 20 bus call button modules with LED lighting BTM 650-01, -02, -03 and -04.

With more than 20 illuminated bus call button modules, an additional TR 603-... is required.

• Max. load of the bus door release contact in the bus line rectifier BNG 650-... 15 V AC, 30 V DC, 2 A

• Max. load of light contact in the bus line rectifier 15 V AC, 30 V DC, 2 A.

**b)** Door release 12 V AC, use at least 20 Ohm (e.g. TÖ 615-...).

For more information, see page 86

• Current consumption bus call button module 20 mA at terminal b/c.

**c)** Conductor length bus indoor device – storey call button ERT max. 50 m.

## 6.1 Installation audio

Siedle Compact

							<p>CA 850-...</p>	<p>Tö 12 V AC min. 20 Ohm</p>	<p>Tö Li Li N L1</p>	<p>BNG 650-...</p>	<p>BTS 850-...</p>																																					<p>Device requirement</p>	<p>B) a)</p>	<p>BFC 850-...</p>	<p>BTC 850-...</p>	<p>AIB 150-...</p>	<p>BTS 850-...</p>
<p>Remarks</p>	<p>b)</p>	<p>c)</p>	<p>c)</p>	<p>c)</p>	<p>c)</p>																																																

## Siedle Compact

### Functional

Calling and speech between the door station and the connected bus indoor devices.

Other bus telephones are not able to listen in to an existing call. Door release button for the door release function, light button for the light switching function. Connection of a storey call button (ERT) for calling from an apartment door. Ringtones can be selected for calls from the front door, apartment door or internal calls. Connection of additional bus telephones or bus door loudspeakers possible at the In-Home bus without accessories.

### Supplementary functions

• **Internal speech communication** between bus indoor devices is only possible internally within the same line.

• **Switching and control functions** are possible with the bus switching modules BSM/BSE/BEM 650-..., feedback to the deluxe bus indoor devices can be programmed.

• **Bus secondary signal unit** BNS 750-... possible.

For more information, see page 92

• **Parallel door and storey call** Up to 4 AIB 150-.../BTS/BTC/BFC 850-... devices can be called simultaneously. With the parallel switching accessory in devices BTC/BFC 850-..., the number can be extended to a maximum of 8. Only possible within a line.

For more information, see page 88

• **Selective dialling of the door station** possible via additional free buttons.

### Remarks

**a)** The BNG 650-... can supply 1 door release.

- Max. load of the bus door release contact in the bus line rectifier BNG 650-... 15 V AC, 30 V DC, 2 A
- Max. load of light contact in the bus line rectifier 15 V AC, 30 V DC, 2 A.

**b)** Door release 12 V AC, use at least 20 Ohm (e.g. TÖ 615-...).

For more information, see page 86

**c)** Conductor length bus indoor device – storey call button ERT max. 50 m.

## 6.1 Installation audio

### Siedle custom-fit door loudspeaker

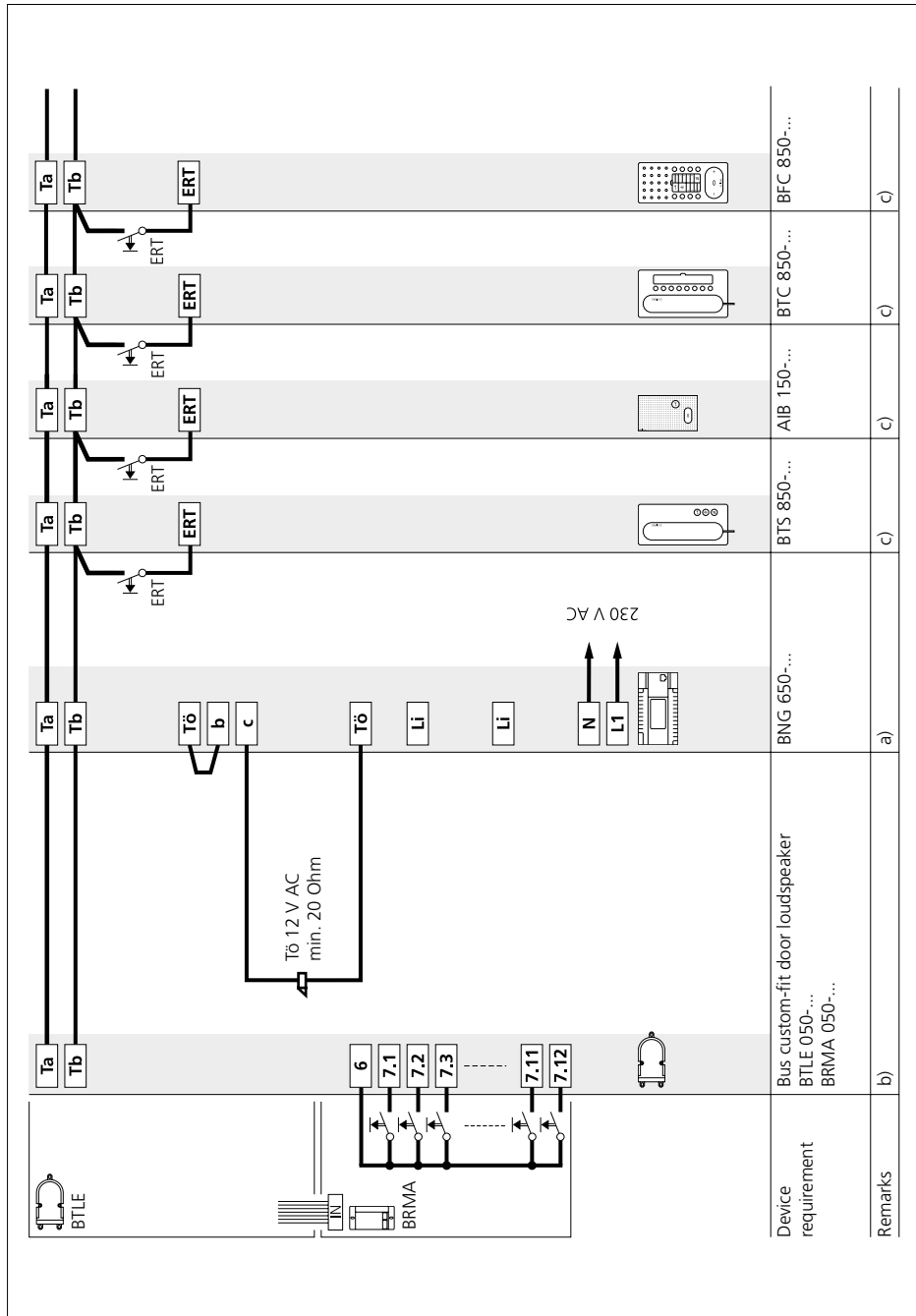

## **Siedle custom-fit door loud-speaker**

### **Functional**

Calling and speech between the door station and the connected bus indoor devices.

Other bus telephones are not able to listen in to an existing call. Door release button for the door release function, light button for the light switching function. Connection of a storey call button (ERT) for calling from an apartment door. Ringtones can be selected for calls from the front door, apartment door or internal calls. Connection of additional bus telephones or bus door loudspeakers possible at the In-Home bus without accessories.

### **Supplementary functions**

• **Internal speech communication** between bus indoor devices is only possible internally within the same line.

• **Switching and control functions** are possible with the bus switching modules BSM/BSE/BEM 650-..., feedback to the deluxe bus indoor devices can be programmed.

• **Bus secondary signal unit** BNS 750-... possible.

For more information, see page 92

• **Parallel door and storey call**

Up to 4 AIB 150-.../BTS/BTC/BFC 850-... devices can be called simultaneously. With the parallel switching accessory in devices BTC/BFC 850-..., the number can be extended to a maximum of 8. Only possible within a line.

For more information, see page 88

• **Selective dialling of the door station** possible via additional free buttons.

### **Remarks**

**a)** The BNG 650-... can also supply the customer's own existing call buttons. A voltage of 12 V AC max. 400 mA is available for the lighting if a door release with an impedance of at least 20 Ohm is used. With a higher current consumption, an additional transformer must be used.

• Max. load of the bus door release contact in the bus line rectifier BNG 650-... 15 V AC, 30 V DC, 2 A

• Max. load of light contact in the bus line rectifier 15 V AC, 30 V DC, 2 A.

**b)** Door release 12 V AC, use at least 20 Ohm (e.g. TÖ 615-...).

For more information, see page 86

**c)** Conductor length bus indoor device – storey call button ERT max. 50 m.

## 6.1 Installation audio

Siedle Classic

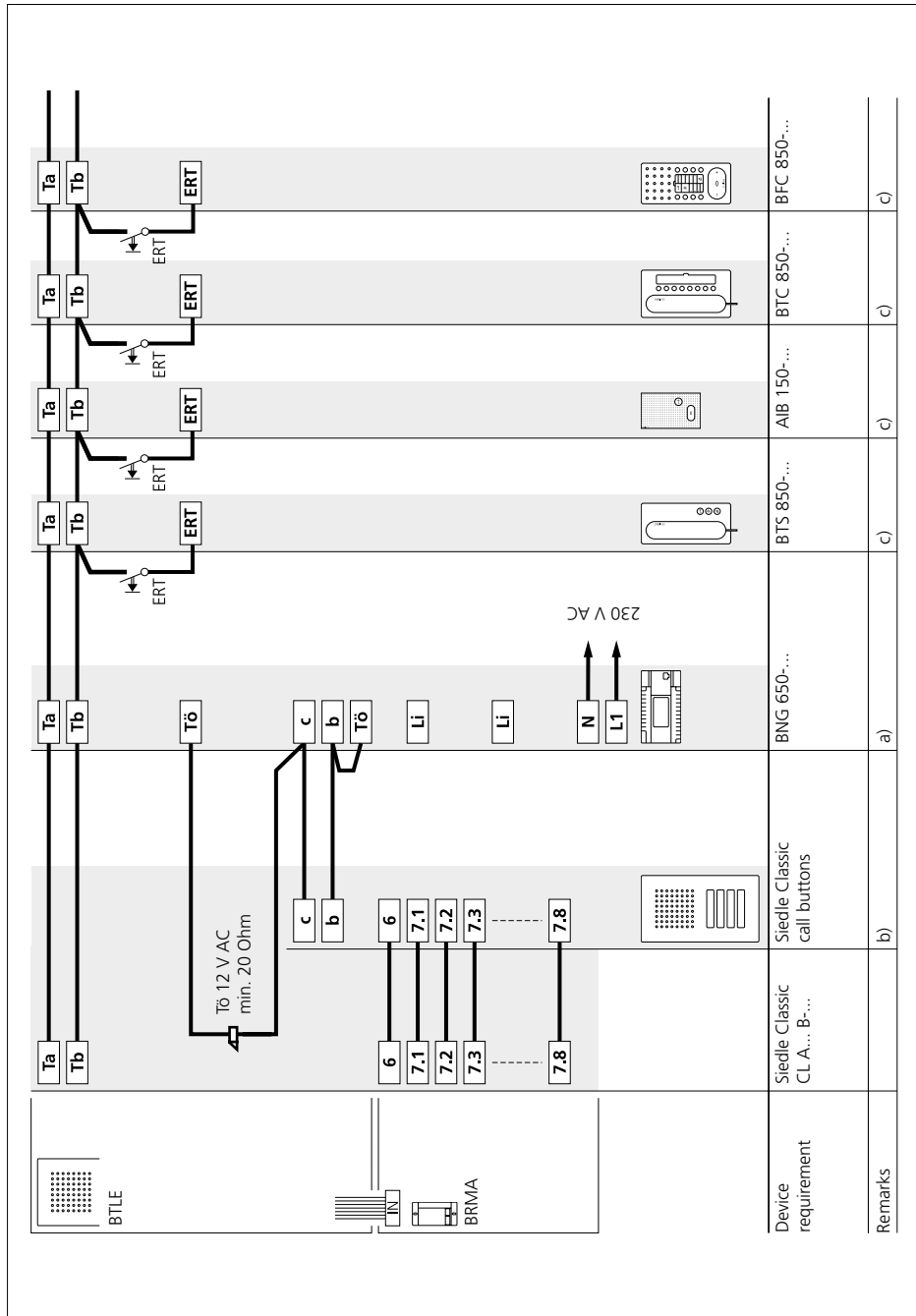

## Siedle Classic

### Functional

Calling and speech between the door station and the connected bus indoor devices.

Other bus telephones are not able to listen in to an existing call. Door release button for the door release function, light button for the light switching function. Connection of a storey call button (ERT) for calling from an apartment door. Ringtones can be selected for calls from the front door, apartment door or internal calls. Connection of additional bus telephones or bus door loudspeakers possible at the In-Home bus without accessories.

### Supplementary functions

• **Internal speech communication** between bus indoor devices is only possible internally within the same line.

• **Switching and control functions** are possible with the bus switching modules BSM/BSE/BEM 650-..., feedback to the deluxe bus indoor devices can be programmed.

• **Bus secondary signal unit** BNS 750-... possible.

For more information, see page 92

• **Parallel door and storey call**

Up to 4 AIB 150-.../BTS/BTC/BFC 850-... devices can be called simultaneously. With the parallel switching accessory in devices BTC/BFC 850-..., the number can be extended to a maximum of 8. Only possible within a line.

For more information, see page 88

• **Selective dialling of the door station** possible via additional free buttons.

### Remarks

- a) The BNG 650-... can supply 1 door release and a maximum of 80 buttons. With more than 80 call buttons, an additional transformer TR 603-... must be used.
- Max. load of the bus door release contact in the bus line rectifier BNG 650-... 15 V AC, 30 V DC, 2 A
  - Max. load of light contact in the bus line rectifier 15 V AC, 30 V DC, 2 A.
- b) Door release 12 V AC, use at least 20 Ohm (e.g. TÖ 615-...).
- For more information, see page 86
- c) Conductor length bus indoor device – storey call button ERT max. 50 m.

## 6.1 Installation audio

Siedle Steel

		Siedle Steel	Device requirement
	BNG 650-...	a)	Remarks
	BNG 650-...	a)	
	BNG 650-...	a)	
	BNG 650-...	a)	
	BNG 650-...	a)	
	BNG 650-...	a)	
	BNG 650-...	a)	
	BNG 650-...	a)	
	BNG 650-...	a)	
	BNG 650-...	a)	



## Siedle Steel

### Functional

Calling and speech between the door station and the connected bus indoor devices.

Other bus telephones are not able to listen in to an existing call. Door release button for the door release function, light button for the light switching function. Connection of a storey call button (ERT) for calling from an apartment door. Ringtones can be selected for calls from the front door, apartment door or internal calls. Connection of additional bus telephones or bus door loudspeakers possible at the In-Home bus without accessories.

### Supplementary functions

• **Internal speech communication** between bus indoor devices is only possible internally within the same line.

• **Switching and control functions** are possible with the bus switching modules BSM/BSE/BEM 650-..., feedback to the deluxe bus indoor devices can be programmed.

• **Bus secondary signal unit** BNS 750-... possible.

For more information, see page 92

• **Parallel door and storey call**

Up to 4 AIB 150-.../BTS/BTC/BFC 850-... devices can be called simultaneously. With the parallel switching accessory in devices BTC/BFC 850-..., the number can be extended to a maximum of 8. Only possible within a line.

For more information, see page 88

• **Selective dialling of the door station** possible via additional free buttons.

### Remarks

**a)** The BNG 650-... can supply 1 door release and a maximum of 130 buttons. With more than 130 call buttons, an additional transformer TR 603-... must be used.

• Max. load of the bus door release contact in the bus line rectifier BNG 650-... 15 V AC, 30 V DC, 2 A

• Max. load of light contact in the bus line rectifier 15 V AC, 30 V DC, 2 A.







**b)** Door release 12 V AC, use at least 20 Ohm (e.g. TÖ 615-...).

For more information, see page 86

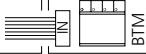
**c)** Conductor length bus indoor device – storey call button ERT max. 50 m.

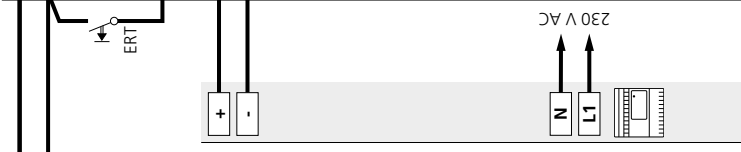
## 6.1 Installation audio

Siedle Vario with Intercom functions

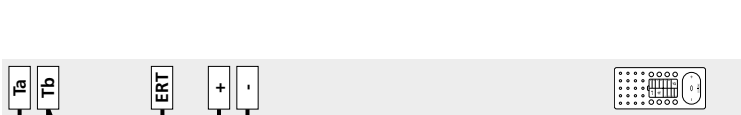
 BTLM	 BTM	 <p>Ta Tb b c T0 Li Li</p> <p>T0 12 V AC min. 20 Ohm</p> <p>230 V AC N L1</p>	 <p>Ta Tb + -</p> <p>230 V AC N L1</p>	 <p>Ta Tb + -</p> <p>ERT</p>	 <p>Ta Tb + -</p> <p>ERT</p>	 <p>Ta Tb + -</p> <p>ERT</p>	 <p>Ta Tb + -</p> <p>ERT</p>	 <p>Ta Tb + -</p> <p>ERT</p>	<p>Device requirement</p> <p>Siedle Vario BTLM 650-... BTM 650-...</p>	<p>NG 706-30/33-...</p>	<p>BFC 850-... + ZPSF 850-...</p>	<p>BFC 850-... + ZPSF 850-...</p>	<p>BFC 850-... + ZPSF 850-...</p>	<p>Remarks</p>	<p>a)</p>	<p>c), x)</p>	<p>c), x)</p>	<p>c), x)</p>
--	--	--	--	--	--	--	--	--	--	-------------------------	---------------------------------------	---------------------------------------	---------------------------------------	----------------	-----------	---------------	---------------	---------------

## Siedle Vario with Intercom functions

### Functional

Calling and speech between the door station and the connected bus indoor devices.

Other bus telephones are not able to listen in to an existing call. Door release button for the door release function, light button for the light switching function. Connection of a storey call button (ERT) for calling from an apartment door. Ringtones can be selected for calls from the front door, apartment door or internal calls. Connection of additional bus telephones or bus door loudspeakers possible at the In-Home bus without accessories.

### Basic functions with all bus indoor devices

- **Internal speech communication** between bus indoor devices is only possible internally within the same line.
- **Switching and control functions** are possible with the bus switching modules BSM/BSE/BEM 650-..., feedback to the deluxe bus indoor devices can be programmed.
- **Bus secondary signal unit** BNS 750-... possible. For more information, see page 92
- **Parallel door and storey call** Up to 4 AIB 150-.../BTS/BTC/BFC 850-... devices can be called simultaneously. With the parallel switching accessory in devices BTC/BFC 850-..., the number can be extended to a maximum of 8. Only possible within a line. For more information, see page 88
- **Selective dialling of the door station** possible via additional free buttons.

### Additional intercom functions

With handsfree bus indoor devices BFC 850-..., additional convenience functions are possible for internal communication.

- Internal call with callback function
- Automatic call pick-up of internal calls
- Internal group call
- Collective paging announcement (\*only with supplementary supply)





### Remarks

- a)** The BNG 650-... is able to supply 1 door release and max. 20 bus call button modules with LED lighting BTM 650-01, -02, -03 and -04. With more than 20 illuminated bus call button modules, an additional TR 603-... is required.
  - Max. load of the bus door release contact in the bus line rectifier BNG 650-... 15 V AC, 30 V DC, 2 A
  - Max. load of light contact in the bus line rectifier 15 V AC, 30 V DC, 2 A.
- b)** Door release 12 V AC, use at least 20 Ohm (e.g. TÖ 615-...). For more information, see page 86
  - Current consumption bus call button module 20 mA at terminal b/c.
- c)** Conductor length bus indoor device – storey call button ERT max. 50 m.
- x)** Supplementary supply to hands-free bus telephones with direct voltage. Required for the function collective paging announcement or parallel door call. Direct voltage is connected at the parallel switching accessory ZPSF 850-... to terminals + and -. A NG 706-30/33-... can supply up to 8 BFC 850-... units with ZPSF 850-...

System programming must be performed using the bus programming software BPS 650-...

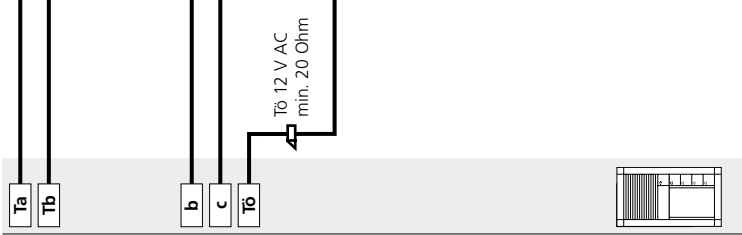
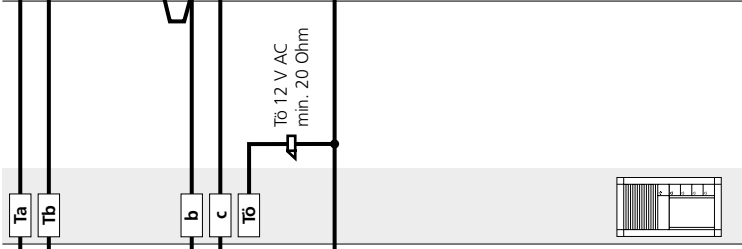
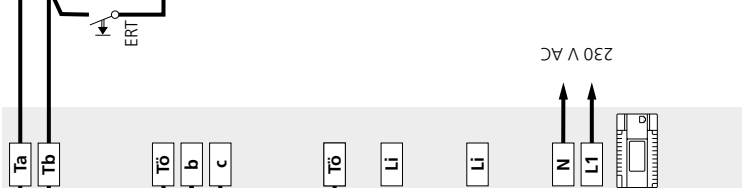
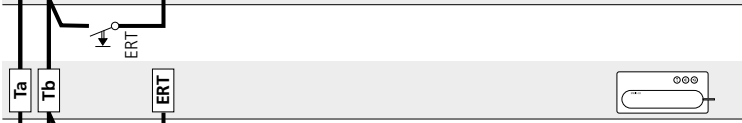
## 6.1 Installation audio

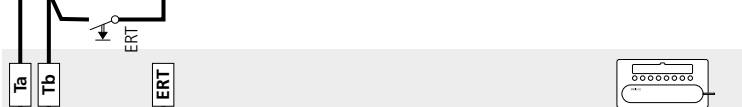
### Siedle Vario 2 door stations

								Device requirement BTLM 650-... BTM 650-...	Siedle Vario BTLM 650-... BTM 650-...	BNG 650-...	BTS 850-...	AIB 150-...	BTC 850-...	BFC 850-...	c)	Remarks	b)	a)	c)	c)	c)	c)	c)
--	--	---	--	--	--	--	--	---	---	-------------	-------------	-------------	-------------	-------------	----	---------	----	----	----	----	----	----	----

## Siedle Vario 2 door stations

### Functional

Calling and speech between the door station and the connected bus indoor devices. Automatic assignment of the door release button to the door station from which the doorbell was last rung.

Other bus telephones are not able to listen in to an existing call. Light button for the light switching function. Connection of a storey call button (ERT) for calling from an apartment door. Ringtones can be selected for calls from the front door, apartment door or internal calls. Connection of additional bus telephones or bus door loudspeakers possible at the In-Home bus without accessories.

### Supplementary functions

- **Internal speech communication** between bus indoor devices is only possible internally within the same line.

- **Switching and control functions** are possible with the bus switching modules BSM/BSE/BEM 650-..., feedback to the deluxe bus indoor devices can be programmed.

- **Bus secondary signal unit** BNS 750-... possible.

For more information, see page 92

- **Parallel door and storey call**

Up to 4 AIB 150-.../BTS/BTC/BFC 850-... devices can be called simultaneously. With the parallel switching accessory in devices BTC/BFC 850-..., the number can be extended to a maximum of 8. Only possible within a line.

For more information, see page 88

- **Selective dialling of the door station** possible via additional free buttons.

### Remarks

**a)** The BNG 650-... is able to supply 1 door release and max. 20 bus call button modules with LED lighting BTM 650-01, -02, -03 and -04.

With more than 20 illuminated bus call button modules, an additional TR 603-... is required.

- Max. load of the bus door release contact in the bus line rectifier BNG 650-... 15 V AC, 30 V DC, 2 A

- Max. load of light contact in the bus line rectifier 15 V AC, 30 V DC, 2 A.

**b)** Door release 12 V AC, use at least 20 Ohm (e.g. TÖ 615-...).

For more information, see page 86

- Current consumption bus call button module 20 mA at terminal b/c.

**c)** Conductor length bus indoor device – storey call button ERT max. 50 m.

## 6.1 Installation

### Multiple line system

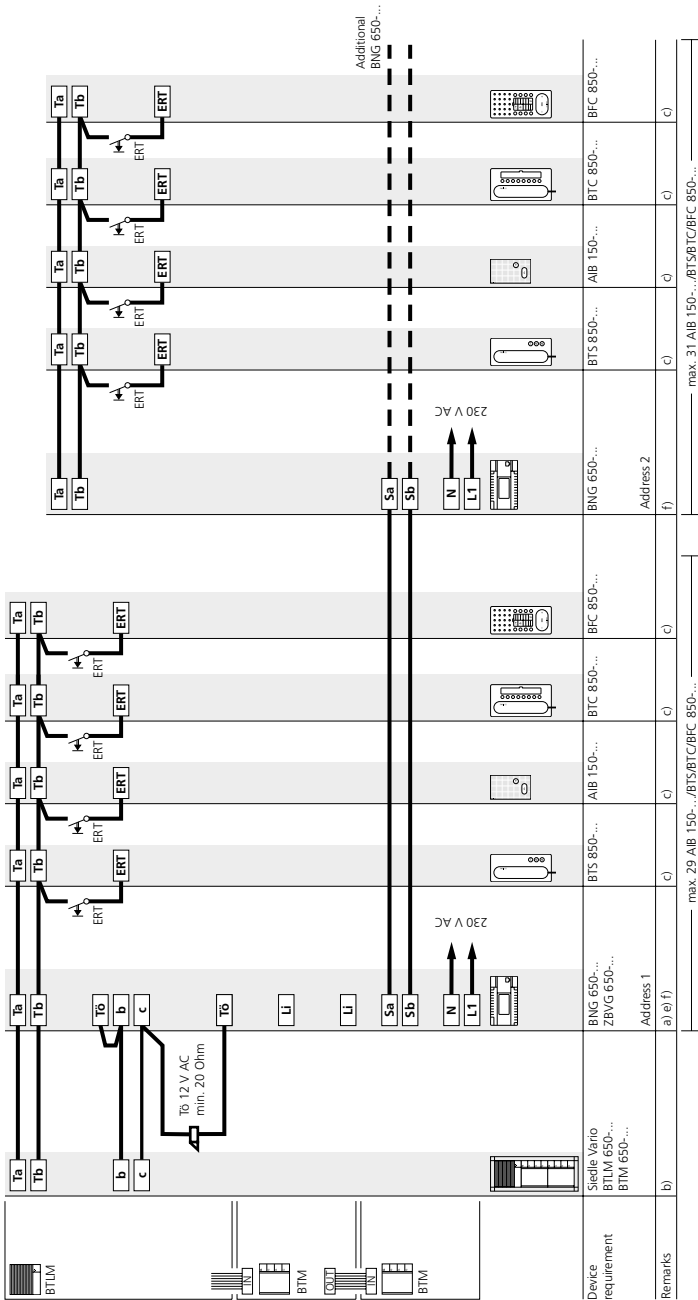

## Multiple line system

### Functional

Calling and speech between the door station and the connected bus indoor devices. Automatic assignment of the door release button to the door station from which the doorbell was last rung.

Other bus telephones are not able to listen in to an existing call. Light button for the light switching function. Connection of a storey call button (ERT) for calling from an apartment door. Ringtones can be selected for calls from the front door, apartment door or internal calls. Connection of additional bus telephones or bus door loudspeakers possible at the In-Home bus without accessories.

In systems with more than 31 users, it is essential for a multiple line system to be configured. A multiple line system can also be used in order to form storey door stations or create functionally separate units such as a doctor's practice. Each line has its own speech channel. Up to 160 users can be called from one door station. Instead of doorbell buttons, the call can also be placed via code lock module COM 611-... or display call module DRM 612-... In this case, up to 465 users can be called from one door station.

### Supplementary functions

• **Internal speech communication** between bus indoor devices is only possible internally within the same line.

• **Switching and control functions** are possible with the bus switching modules BSM/BSE/BEM 650-..., feedback to the deluxe bus indoor devices can be programmed.

• **Bus secondary signal unit** BNS 750-... possible.

For more information, see page 92

• **Parallel door and storey call**

Up to 4 AIB 150-.../BTS/BTC/BFC 850-... devices can be called simultaneously. With the parallel switching accessory in devices BTC/BFC 850-..., the number can be extended to a maximum of 8.

Only possible within a line.

For more information, see page 88

• **Selective dialling of the door station** possible via additional free buttons.

### Remarks

**a)** The BNG 650-... is able to supply 1 door release and max. 20 bus call button modules with LED lighting BTM 650-01, -02, -03 and -04.

With more than 20 illuminated bus call button modules, an additional TR 603-... is required.

• Max. load of the bus door release contact in the bus line rectifier BNG 650-... 15 V AC, 30 V DC, 2 A

• Max. load of light contact in the bus line rectifier 15 V AC, 30 V DC, 2 A.

**b)** Door release 12 V AC, use at least 20 Ohm (e.g. TÖ 615-...).

For more information, see page 86

• Current consumption bus call button module 20 mA at terminal b/c.

**c)** Conductor length bus indoor device – storey call button ERT max. 50 m.

**e)** One bus line rectifier accessory ZBVG 650-... only is required in the entire system.

**f)** If several BNG/BVNG 650-... units are installed in one system, their addresses must differ.

## 6.1 Installation audio

Call via display call module

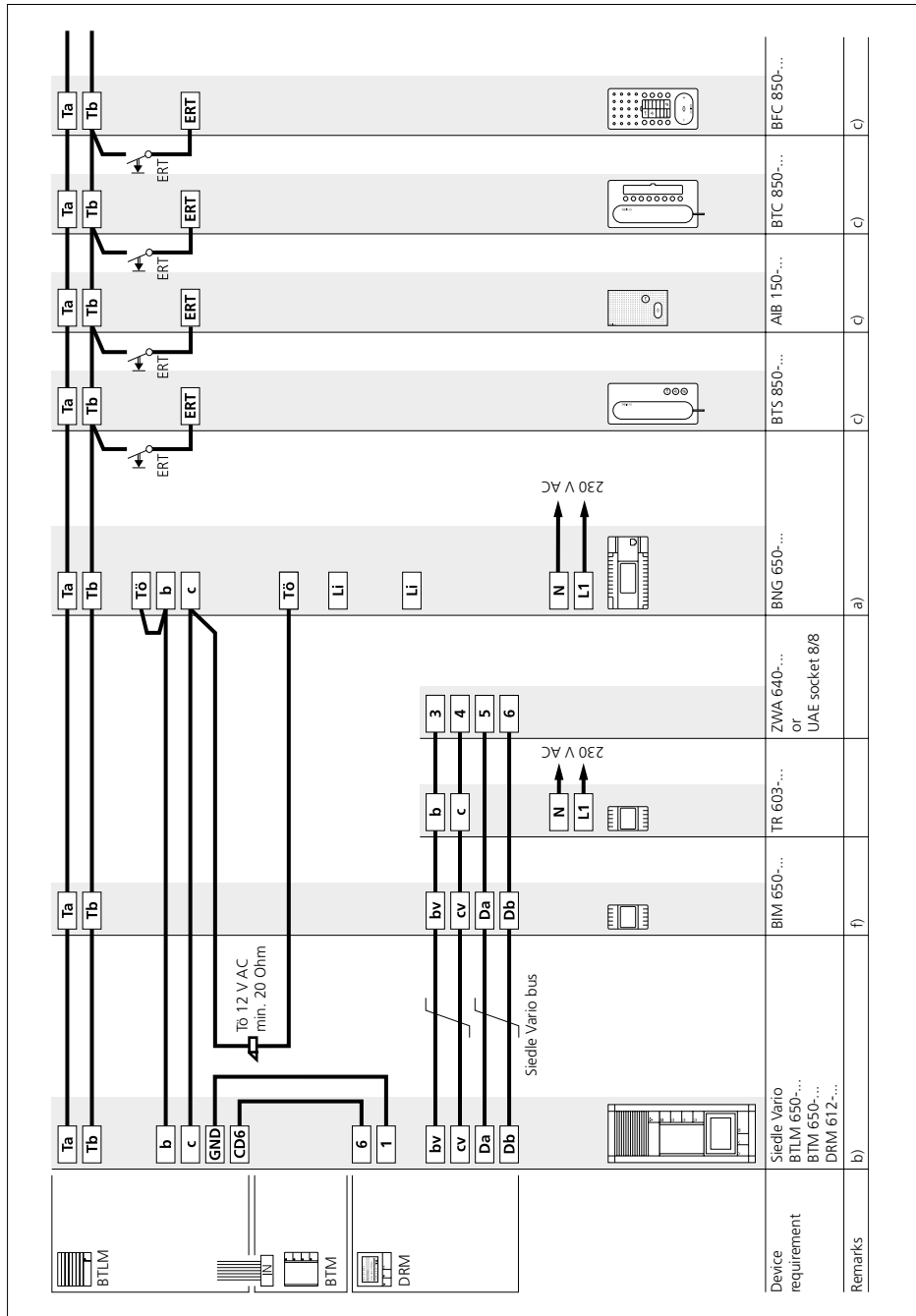



## Call via display call module

### Functional

Calling and speech between the door station and the connected bus indoor devices. Dialling of bus telephones via the display call module. Selection of names takes place in alphabetical order.

Other bus telephones are not able to listen in to an existing call. Door release button for the door release function, light button for the light switching function. Connection of a storey call button (ERT) for calling from an apartment door. Ringtones can be selected for calls from the front door, apartment door or internal calls. Connection of additional bus telephones or bus door loudspeakers possible at the In-Home bus without accessories.

### Supplementary functions

• **Internal speech communication** between bus indoor devices is only possible internally within the same line.

• **Switching and control functions** are possible with the bus switching modules BSM/BSE/BEM 650-..., feedback to the deluxe bus indoor devices can be programmed.

• **Bus secondary signal unit** BNS 750-... possible.

For more information, see page 92

• **Parallel door and storey call**

Up to 4 AIB 150-.../BTS/BTC/BFC 850-... devices can be called simultaneously. With the parallel switching accessory in devices BTC/BFC 850-..., the number can be extended to a maximum of 8.

Only possible within a line. For more information, see page 88

• **Selective dialling of the door station** possible via additional free buttons.

### Remarks

**a)** The BNG 650-... is able to supply 1 door release and max. 20 bus call button modules with LED lighting BTM 650-01, -02, -03 and -04.

With more than 20 illuminated bus call button modules, an additional TR 603-... is required.

• Max. load of the bus door release contact in the bus line rectifier BNG 650-... 15 V AC, 30 V DC, 2 A

• Max. load of light contact in the bus line rectifier 15 V AC, 30 V DC, 2 A.

**b)** Door release 12 V AC, use at least 20 Ohm (e.g. TÖ 615-...).

For more information, see page 86

• Current consumption bus call button module 20 mA at terminal b/c.

**c)** Conductor length bus indoor device – storey call button ERT max. 50 m.

**f)** Names are programmed using a Windows PC via programming interface PRI 602-... The software PRS 602-... first needs to be installed.

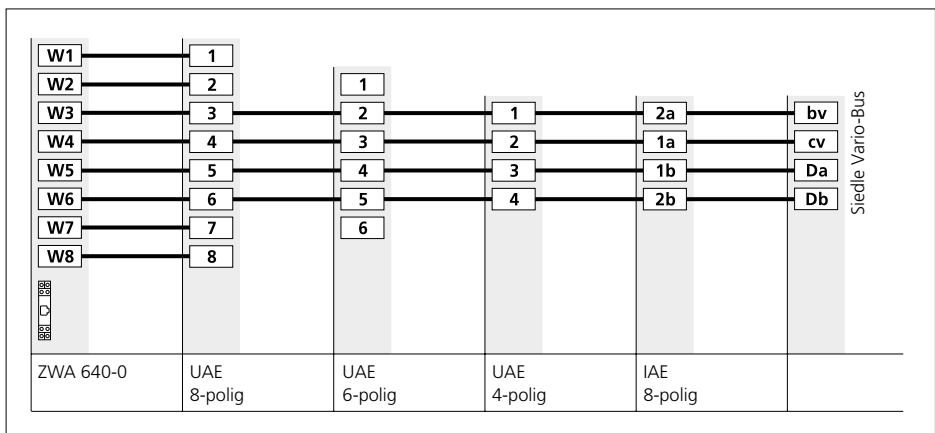

## 6.1 Installation audio

DoorCom Analog DCA 650-...

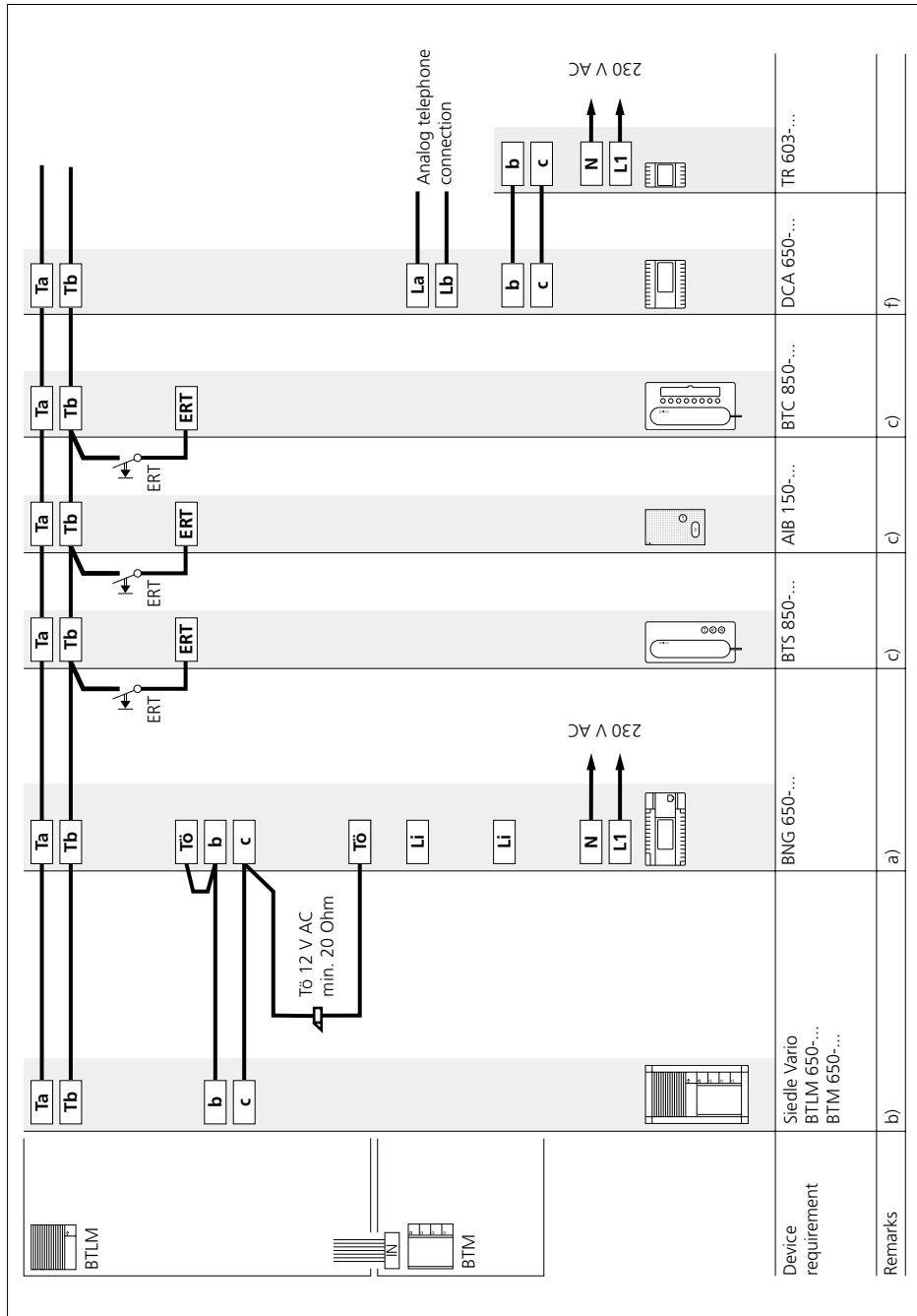

## DoorCom Analog DCA 650-...

### Functional

Calling and speech between the door station and the connected a/b telephones of a telephone system. The DoorCom-Analog DCA 650-... is able to forward the call from up to 31 bell buttons to a telephone system. The DCA 650-... calls the PBX extensions of the telephone system using dual-tone multiple frequency dialling DTMF. Other bus telephones are not able to listen in to an existing call. Door release and light switching functions are possible via DTMF to connected a/b telephones of the telephone system.

### Supplementary functions

It is also possible to connect bus telephones to the door station. Switching and control functions can be triggered via the DCSF 600-... For this, the connected telephones of the telephone system call the PBX extension of the DCA 650-... and execute the function by means of DTMF dialling.

### Remarks

**a)** The BNG 650-... is able to supply 1 door release and max. 20 bus call button modules with LED lighting BTM 650-01, -02, -03 and -04.

With more than 20 illuminated bus call button modules, an additional TR 603-... is required.

- Max. load of the bus door release contact in the bus line rectifier BNG 650-... 15 V AC, 30 V DC, 2 A
- Max. load of light contact in the bus line rectifier 15 V AC, 30 V DC, 2 A.

**b)** Door release 12 V AC, use at least 20 Ohm (e.g. TÖ 615-...).

For more information, see page 86

- Current consumption bus call button module 20 mA at terminal b/c.

**c)** Conductor length bus indoor device – storey call button ERT max. 50 m.

**f)** If the predecessor model DCA 650-0 is used, the operating mode switch of the BNG 650-... must be in position 1. The maximum distance of the DCA 650-... from the TR 603-... is 20 m. If several DCA 650-... units are used within a system, each DCA 650-... must be supplied by its own transformer.

## 6.2 Siedle Systemtechnik installation

Jung audio indoor station

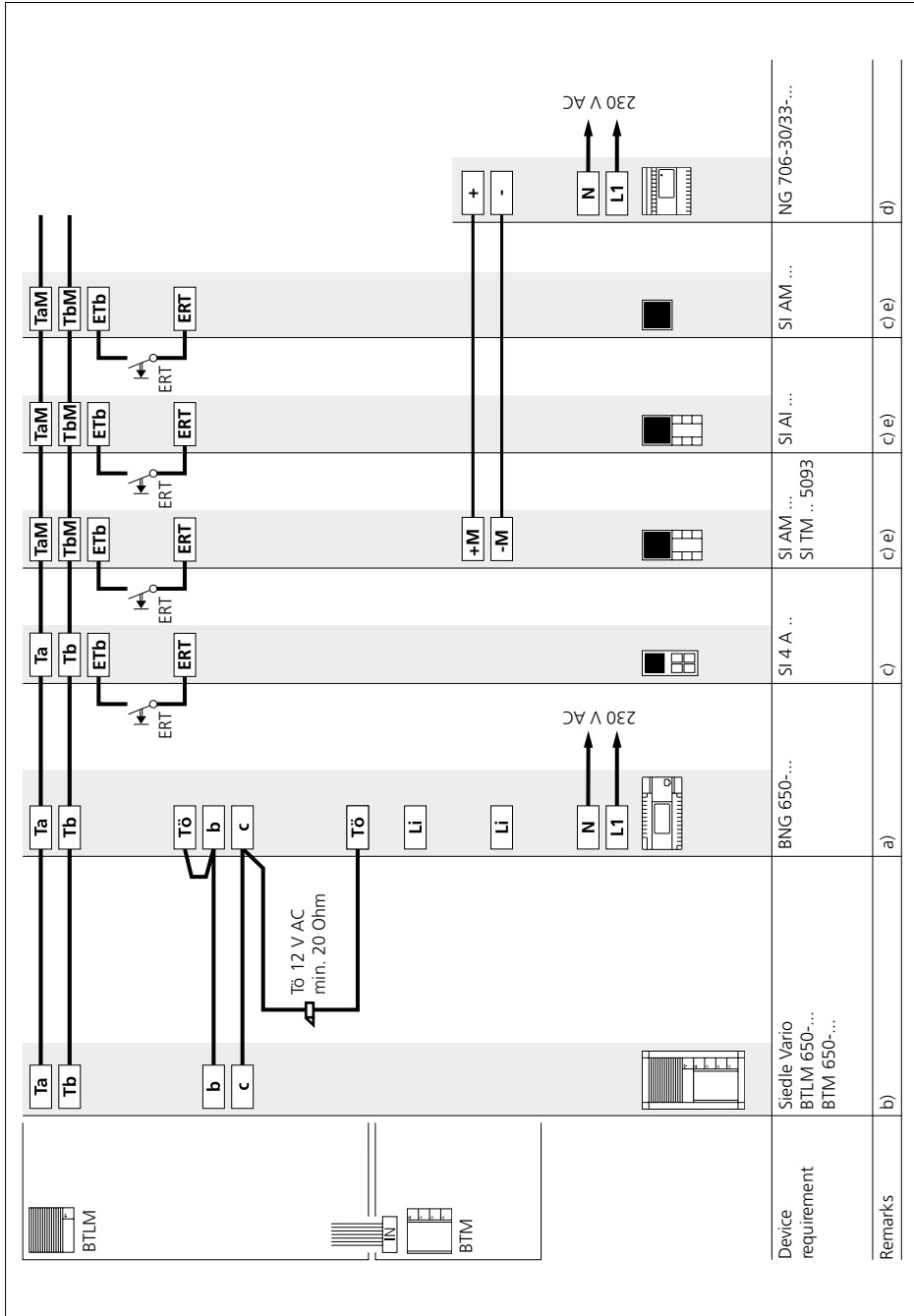

**Jung audio indoor station**

Calling and speech between door stations and the connected Jung indoor devices. Automatic assignment of the door release button to the door station from which the doorbell was last rung. Other bus telephones are not able to listen in to an existing call. Door release button for the door release function, light button for the light switching function. Connection of a storey call button (ERT) for calling from an apartment door. Ringtones can be selected for calls from the front door, apartment door or internal calls. Connection of additional bus telephones or bus door loudspeakers possible at the In-Home bus without accessories.

**Supplementary functions**

- **Internal speech communication** between bus indoor devices is only possible internally within the same line.
- **Switching and control functions** are possible with the bus switching modules BSM/BSE/BEM 650-..., feedback to the deluxe bus indoor devices and Jung indoor devices can be programmed.
- **Bus secondary signal unit** BNS 750-... possible. For more information, see page 92
- **Parallel door and storey call** Up to 4 audio indoor stations can be called simultaneously via one bell button without an additional supply. Only possible within a line. For more information, see page 88
- **Selective dialling of the door station** possible via additional free buttons.

**Remarks**

- a)** The BNG 650-... is able to supply 1 door release and max. 20 bus call button modules with LED lighting BTM 650-01, -02, -03 and -04. With more than 20 illuminated bus call button modules, an additional TR 603-... is required.
  - Max. load of the bus door release contact in the bus line rectifier BNG 650-... 15 V AC, 30 V DC, 2 A
  - Max. load of light contact in the bus line rectifier 15 V AC, 30 V DC, 2 A.
- b)** Door release 12 V AC, use at least 20 Ohm (e.g. TÖ 615-...). For more information, see page 86
- Current consumption bus call button module 20 mA at terminal b/c.
- c)** Conductor length bus indoor device – storey call button ERT max. 50 m.
- d)** The Jung Universal call button module can be supplied with a direct voltage of (22–30 V DC, 170 mA). The NG 706-30/33-... can be used for this purpose.
- e)** The Jung audio module is connected directly to the In-Home bus audio.

## 6.2 Siedle Systemtechnik installation

Siedle and Jung indoor stations combined

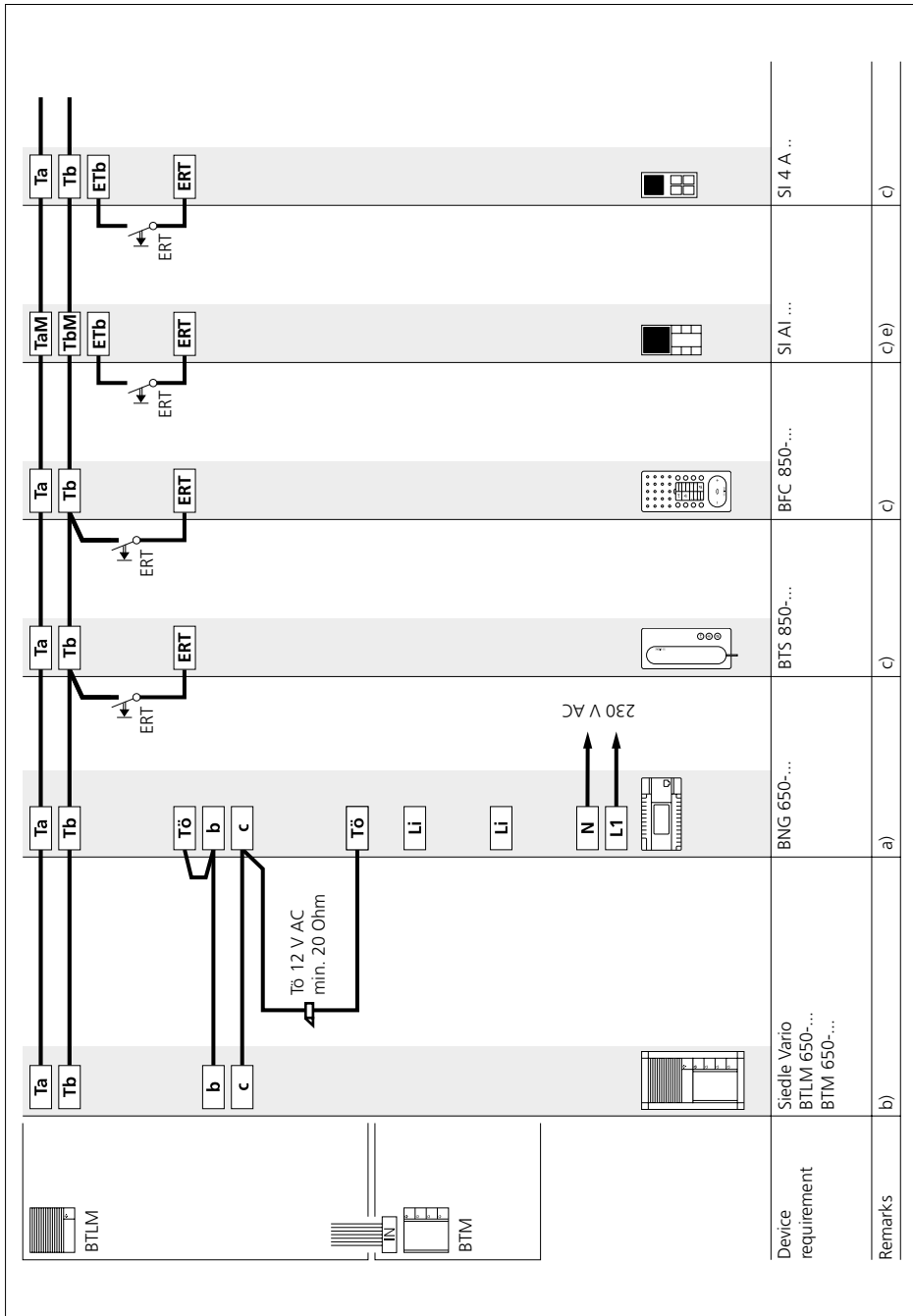

## Siedle and Jung indoor stations combined

Calling and speech between door stations and the connected Jung indoor devices. Automatic assignment of the door release button to the door station from which the doorbell was last rung.

Other bus telephones are not able to listen in to an existing call. Door release button for the door release function, light button for the light switching function. Connection of a storey call button (ERT) for calling from an apartment door. Ringtones can be selected for calls from the front door, apartment door or internal calls. Connection of additional bus telephones or bus door loudspeakers possible at the In-Home bus without accessories.

## Supplementary functions

- **Internal speech communication** between bus indoor devices is only possible internally within the same line.

- **Switching and control functions** are possible with the bus switching modules BSM/BSE/BEM 650-..., feedback to the deluxe bus indoor devices and Jung indoor devices can be programmed.

- **Bus secondary signal unit** BNS 750-... possible.

For more information, see page 92

- **Parallel door and storey call** Up to 4 audio indoor stations can be called simultaneously via one bell button without an additional supply. Only possible within a line.

For more information, see page 88

- **Selective dialling of the door station** possible via additional free buttons.

## Remarks

**a)** The BNG 650-... is able to supply 1 door release and max. 20 bus call button modules with LED lighting BTM 650-01, -02, -03 and -04.

With more than 20 illuminated bus call button modules, an additional TR 603-... is required.

- Max. load of the bus door release contact in the bus line rectifier BNG 650-... 15 V AC, 30 V DC, 2 A

- Max. load of light contact in the bus line rectifier 15 V AC, 30 V DC, 2 A.

**b)** Door release 12 V AC, use at least 20 Ohm (e.g. TÖ 615-...).

For more information, see page 86

Current consumption bus call button module 20 mA at terminal b/c.

**c)** Conductor length bus indoor device – storey call button ERT max. 50 m.

**e)** The Jung audio module is connected directly to the In-Home bus audio.

## 7 Programming

### Overview of functions

Functions with Siedle In-Home and programming possibilities. Terms used in the table are explained in detail on the next page.

- not available
- /-/ Plug+Play programming
- /•/- Manual programming
- /-/• PC programming

\* (from V 4.0)

#### Basic functions

	AIB 150-01	BTS 850-...	BTC 850-...	BFC 850-...
Door call	•/•/•	•/•/•	•/•/•	•/•/•
-Storey call				
-Door release button				
-Light button				
-Call silencing and display (Functional following installation)				
Dialling last door (Functional following installation)	-/-/•	-/-/•	-/-/•	-/-/•
Call tone configuration	-/•/•	-/•/•	-/•/•	-/•/•
Setting at the bus indoor device				
<b>Supplementary functions</b>				
BSE Groups	-/-/•	-/-/•	-/-/•	-/-/•
Group formation	-/•/•	-/-/•	-/-/•	-/-/•
Internal call	-	-/•/•	-/•/•	-/•/•
Camera step	-	-	-	-
Secondary signal unit	-/-/•	-/•/•	-/•/•	-/•/•
Parallel device	-/-/•	-/•/•	-/•/•	-/•/•
Status display (via LED)	-	-	-/-/•	-/-/•
Control function	-/-/•	-/-/•	-/•/•	-/•/•
Door dialling	-	-/•/•	-/•/•	-/•/•
Doormatic	-	-	-/-/•	-/-/•
Door call acceptance	-	-/-/•	-/-/•	-/-/•
Door call forwarding	-	-	-/-/•	-/-/•
Time for light contact	-/-/•	-/-/•	-/-/•	-/-/•
Second button level	-/-/•	-/-/•	-/-/•	-/-/•
<b>Intercom functions</b>				
Internal group call	-	-	-/-/•	-/-/•
Collective announcement*	-	-	-	-/-/•
Automatic call acceptance	-	-	-	-/-/•
Set call-back	-	-	-/-/•	-/-/•
Receive callback	-	-	-/-/•	-/-/•



**Basic functions**

	SI 4 A..	SI A1 ...
Door call	•/•/•	•/•/•
-Storey call		
-Door release button		
-Light button		
-Call silencing and display (Functional following installation)		
Dialling last door (Functional following installation)	-/-/•	-/-/•
Call tone configuration	-/•/•	-/•/•
Setting at the bus indoor device		
<b>Supplementary functions</b>		
BSE Groups	-/-/•	-/-/•
Group formation	-/-/•	-/-/•
Internal call	-/•/•	-/•/•
Camera step	-	-
Secondary signal unit	-/•/•	-/•/•
Parallel device	-/•/•	-/•/•
Status display (via LED)	-/-/•	-/-/•
Control function	-/•/•	-/•/•
Door dialling	-/•/•	-/•/•
Doormatic	-	-/-/•
Door call acceptance	-/-/•	-/-/•
Door call forwarding	-	-/-/•
Time for light contact	-/-/•	-/-/•
Second button level	-	-
<b>Intercom functions</b>		
Internal group call	-	-/-/•
Collective announcement*	-	-
Automatic call acceptance	-	-/-/•
Set call-back	-	-/-/•
Receive callback	-	-/-/•

## 7 Programming

### Overview of functions

#### Dialling last door

The door station from which the last door call was placed can be dialled by double clicking the light button.

#### Automatic call acceptance

The handsfree indoor device automatically picks up incoming internal calls and switches on the speech connection.

#### BSE Groups

Several bus switching units are assigned to a group. This allows several BSE 650-... units to be executed simultaneously with one switching contact, e.g. shutter control.

#### Storey call

The storey call button (ERT) is used to call into the apartment from an apartment door. Application e.g. apartment building with 4 apartments and a common staircase. Storey call buttons are installed in front of every apartment front door.

#### Group formation

Several bus indoor devices are assigned to a group. This allows up to 8 bus indoor devices to be called with one button. A bus indoor device can belong to up to 4 different groups.

#### Intercom

The term Intercom denotes internal communication within one building. Using handsfree bus indoor devices, intercom communication is particularly simple and convenient, as it does not require a receiver to be lifted.

#### Internal call

Bus indoor devices can place calls to each other using the buttons. Using the standard indoor device, 4 users can be called. The deluxe indoor devices are able to call up to 14 users. Internal calls are only possible within a line.

#### Internal group call

Internal call to several indoor devices simultaneously. The device which initially establishes the connection has the call.

#### Light button

In the as-delivered status, the light button in the bus indoor device switches the contact in the bus line rectifier for 0.4 seconds. Using the bus programming software BPS 650-... this time can be altered. The function of the light button can be reprogrammed, e.g. for internal calls.

#### Secondary signal unit

The interfacing relay accessory is available for bus telephones BTS/ BTC 850-... for actuating a signalling device or a lamp. For BFC 850-... use accessory ZARF 850-... A bus secondary signal unit BNS 750-... can be programmed in parallel to a bus indoor device.

#### Parallel device

Max. 8 bus indoor devices can ring simultaneously when actuating a doorbell button.

#### Call silencing and display

The call can be switched off at the bus indoor devices. Deactivation is signalled at the device.

#### Call tone configuration

At each bus indoor device, different call tones can be selected for every call type (door call, internal call, storey call).

#### Receive callback

If you are available to accept an internal call, a callback can be requested. This is optically signalled at the deluxe indoor device. This function can be programmed at all deluxe bus indoor devices.

#### Set call-back

If you make an internal call and the user does not pick up, you can request a callback. To do this, press the flashing button twice.

#### Collective announcement

Paging announcement to one or more deluxe handsfree devices (from V 4.0). Can be used for instance for making an announcement in a waiting room or for searching for individual personnel in a building.

#### Status display (via LED)

The supplementary devices bus switching module BSE 650-... and bus input module BEM 650-... send feedback signals to the In-Home bus. These can be displayed at the bus indoor devices, e.g. whether the garage door is open.

#### Control function

The supplementary devices bus switching unit BSE 650-..., bus input module BEM 650-... and bus switching module BSM 650-... can execute different switching and control functions for individual operations.

#### Teach-in

Term for manual programming of bus users.

**Door dialling**

One or more door stations can be selectively dialled and a speech connection established.

**Doormatic**

The door release contact in the bus video line rectifier and in the calling bus door loudspeaker switches for 3 seconds after the door bell button has been pressed. The function can be actively switched from the deluxe bus indoor device.

**Door release button**

The door release button on the bus indoor device always switches the DR contact at the bus line rectifier for 3 seconds and the DR contact in the door loudspeaker which placed the call.

**Door call**

When a visitor presses the door bell button, the bus telephone rings and the call silencing button flashes. In handsfree bus telephones, the speech button flashes.

**Door call acceptance**

A door call from a bus telephone can be accepted in a different room.

**Door call forwarding**

The door call can be re-routed from a deluxe bus indoor device by pressing a button to a different bus indoor device, e.g. rerouting of a door call from the secretary to the caretaker. The bus indoor devices must be located in the same line.

**Time for light contact**

The switching time of the light contact is 0.4 seconds in the as-delivered status. This time can be altered using the bus programming software BPS 650-... from V 2.50.

## 7 Programming

### Remarks

The In-Home bus can be programmed in three ways:

#### 1 Programming – manual

For more information, see page 52

#### 2 Programming – Plug+Play

For more information, see page 80

#### 3 Programming – with PC

For more information, see page 84

#### Important remarks prior to programming

- The entire installation must have been completed. When programming using the Plug+Play method, the housing of the bus indoor devices must not yet be closed.
- Before starting programming, all buttons should be inscribed to allow them to be assigned to the relevant bus indoor devices.
- It is only ever possible to activate one door loudspeaker in the programming mode.
- If an already programmed call button is pressed for longer than 3 seconds in the programming mode at the activated door loudspeaker, after one second a warningtone is sounded, and after 3 seconds the confirmation tone. After this, the call button is deleted if there was no bus indoor device active. However, if there is a bus indoor device active at this moment, the button is overwritten with the new address.
- All BNG/BVNG 650-... units must be connected to mains voltage of 230 V AC.
- In multiple line systems with several BNG/BVNG 650-... units, actuating the Prog. mode button **at one** BNG/BVNG 650-... switches all other connected BNG/BVNG 650-... units to the programming mode.
- In multiple line systems, at each BNG/BVNG 650-... **a different address** must be set. **The number "0" cannot be used as an address!**

- In multiple line systems bus power supply accessory ZBVG 650-... must be additionally plugged into one BNG/BVNG 650-... The bus video line rectifier accessory ZBVNG 650-... must be plugged into each BVNG 650-...

#### Programming – manual

##### Procedure:

On principle, the In-Home bus can be commissioned and programmed by one person. However, as work has to be executed both at the door loudspeaker and the bus indoor device, we recommend that commissioning be carried out by two people for larger-scale projects.

- Complete the installation
- Check the switch positions at the BNG/BVNG 650-..., in new systems set the switch setting to Norm.
- Activate the programming mode at the bus line rectifier
- Set the door station to the programming mode
- Program the users
- Quit the programming mode

While the bus line rectifier is in the programming mode, several steps can be programmed in sequence. There is no need to quit the programming mode after every operation.

##### Handsfree bus telephones

Picking up and replacing the receiver are no longer necessary when using handsfree bus telephones AIB 150-... and BFC 850-...

The AIB 150-... switches to the programming mode by pressing the speech button.

The BFC 850-... switches to the programming mode by pressing the light button.

Once the programming step has been performed, the device switches back to the idle status. All other programming steps are identical.

## 7.1 Programming – manual

### Activating the bus line rectifier

To activate the programming mode at the bus line rectifier, the programming mode button has to be briefly pressed down. LED 1 indicates whether the programming mode is switched on. After activating the programming mode, LED 1 changes over from normal mode to programming mode.

#### Indication at LED 1 Function display

LED flashes briefly **0.02 seconds** – long pause **1 second** ■ Pause ■ Pause ■ Pause ■ etc.

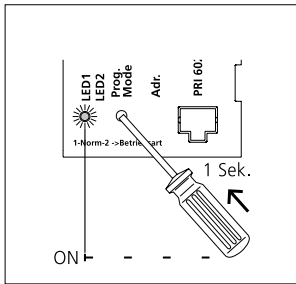

Using a small screwdriver, set the bus line rectifier to the programming mode through the opening in the cover.

#### Note:

If no programming process takes place within 10 minutes, the BNG 650-... switches back to the standard operating mode.

#### Indication at LED 1 Programming mode active

LED flashes briefly **0.3 seconds** – long pause **2 seconds** ■ Pause ■ Pause ■ etc.

## 7.1 Programming – manual

### Activating the bus door loudspeaker

Depending on the type of door station, the programming mode has to be activated in a different way.

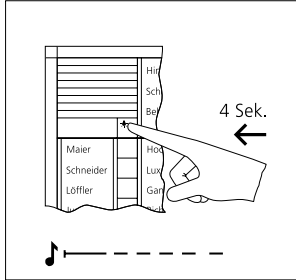

#### 1 Siedle Vario

In the case of door loudspeaker module BTLM 650-... the programming mode is activated using the light button. Hold down the light button for 4 seconds until a protracted signal tone is audible.

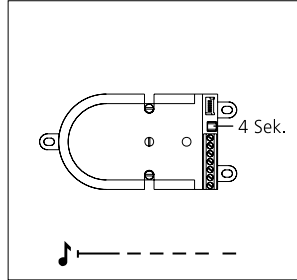

#### 2 Siedle custom-fit door loudspeaker

In the case of the BTLE 050-... the programming mode is activated using the programming button. Next to the terminal, hold down the programming button for 4 seconds until a protracted signal tone is audible.

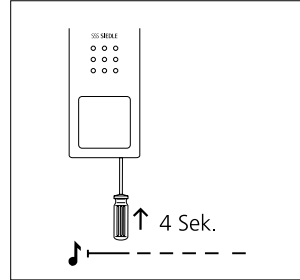

#### 3 Siedle Compact

At the door station, hold down the programming button for 4 seconds. A protracted acknowledgement tone is then audible which is repeated every 5 seconds as long as the programming mode remains active.

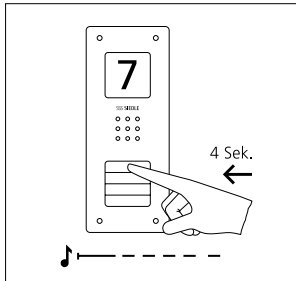

#### 4 Siedle Compact flush mounting

At the door station, hold down the top bell button for 4 seconds. A protracted acknowledgement tone is then audible which is repeated every 5 seconds as long as the programming mode remains active.

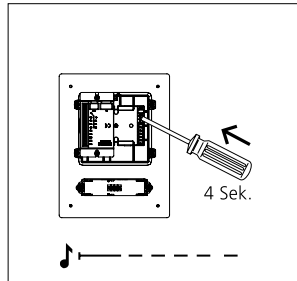

#### 5 Siedle Classic

On the door station, press and hold the programming button behind the front panel for 4 seconds. A sustained acknowledgement tone will sound, which briefly repeats every 5 seconds while programming mode is active.

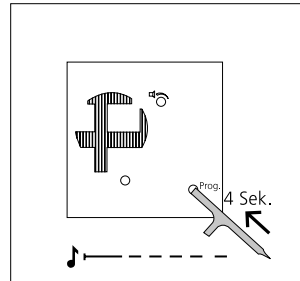

#### 6 Siedle Steel

The programming button is only accessible with the operating panel removed. To actuate the programming button, use the blunt end of the plastic key inserted in the inspection shaft cover. Hold down the light button for 4 seconds until a protracted signal tone is audible.

## Activating the indoor devices

Depending on the type of bus indoor device, the programming mode has to be activated in a different way.

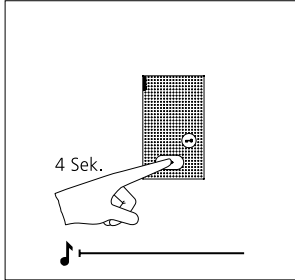

### 1 Siedle Basic

Hold down the speech button for 4 seconds. A protracted acknowledgement tone sounds as confirmation and the muting LED begins to flash. The bus indoor device establishes the speech connection to the door station. The bus indoor device is now in the programming mode.

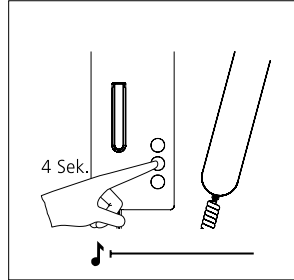

### 2 Bus telephone

Lift the receiver at the bus telephone which you wish to program. Hold down the light button for 4 seconds. A protracted acknowledgement tone is audible in the receiver as confirmation. The bus telephone is now in the programming mode. Do not replace the receiver until after programming has been completed at the bus telephone.

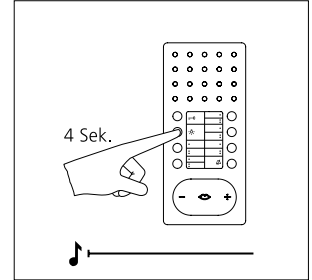

### 3 Bus handsfree telephone

Hold down the light button for 4 seconds. A protracted acknowledgement tone sounds as confirmation and the muting button begins to flash. The bus handsfree telephone establishes the speech connection to the door station. The bus handsfree telephone is now in the programming mode.

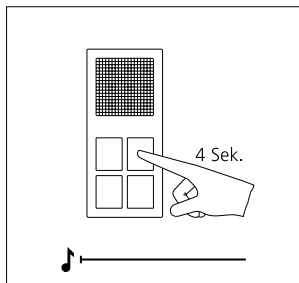

**1 Activate the standard audio indoor station**

Hold down the light button for 4 seconds. A protracted acknowledgement tone sounds as confirmation and the muting button begins to flash. The standard audio indoor station establishes the speech connection to the door station. The standard audio indoor station is now in the programming mode.

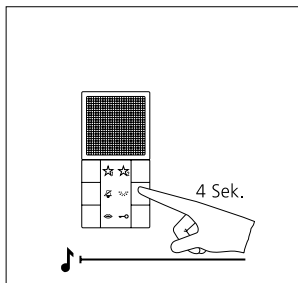

**2 Activate the audio indoor station**

Hold down the light button for 4 seconds. A protracted acknowledgement tone sounds as confirmation and the muting button begins to flash. The audio indoor station establishes the speech connection to the door station. The audio indoor station is now in the programming mode.



## Door call to Siedle Basic

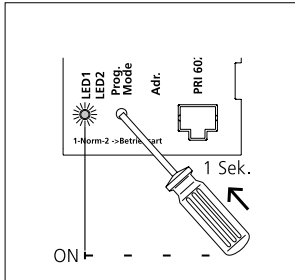

**1** Switch on the programming mode. At the BNG/BVNG 650-..., press the programming mode button briefly. The LED 1 flashes in a 2-second rhythm to indicate that the programming mode is active.

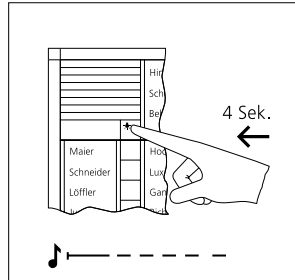

**2** At the door station, hold down the light/programming button for 4 seconds. A protracted acknowledgement tone is then audible which is repeated every 5 seconds as long as the programming mode remains active.

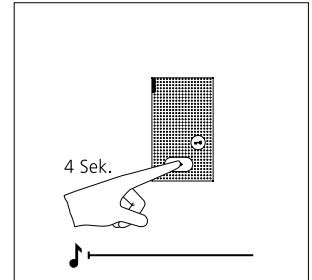

**3** Hold down the speech button for 4 seconds. A protracted acknowledgement tone sounds as confirmation and the muting LED begins to flash. The bus indoor device establishes the speech connection to the door station. The bus indoor device is now in the programming mode.

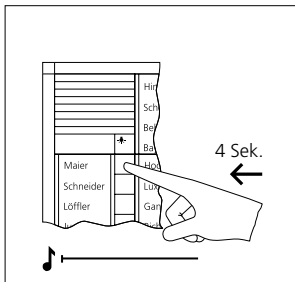

**4** On the door station, press and hold the desired call button for 4 seconds until a sustained tone can be heard from the door loudspeaker. The call button is now assigned to the bus indoor device.

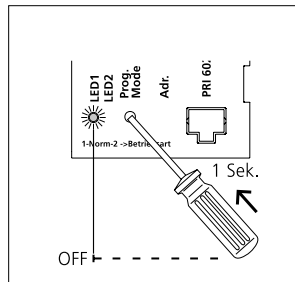

**5** The call button is now firmly assigned to the handsfree bus telephone.

Program additional users using the same procedure or quit the programming mode.

## 7.1 Programming – manual

### Door call to bus telephone

At the bus telephone, a different ringtone optionally be selected. The volume of the door call can be changed at the bus telephone.

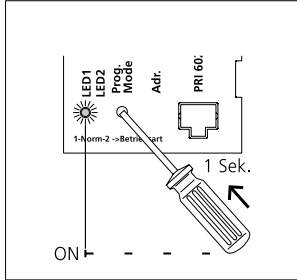

**1** Switch on the programming mode. At the BNG/BVNG 650-..., press the programming mode button briefly. The LED 1 flashes in a 2-second rhythm to indicate that the programming mode is active.

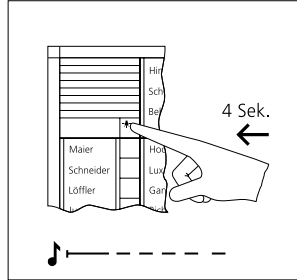

**2** At the door station, hold down the light/programming button for 4 seconds. A protracted acknowledgement tone is then audible which is repeated every 5 seconds as long as the programming mode remains active.

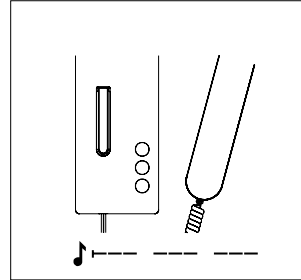

**3** Lift the receiver at the bus telephone which you wish to program.

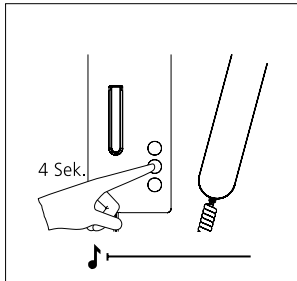

**4** Hold down the light button for 4 seconds. A protracted acknowledgement tone sounds in the receiver, the muting button flashes. A speech connection exists to the door station. The bus telephone is now in the programming mode. Leave the receiver off the hook.

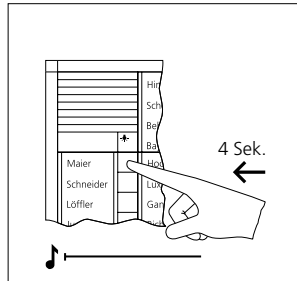

**5** On the door station, press and hold the desired call button for 4 seconds until a sustained tone can be heard from the door loudspeaker. The call button is now assigned to the bus indoor device.

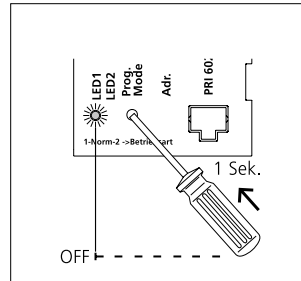

**6** The call button is now firmly assigned to the handsfree bus telephone.

Program additional users using the same procedure or quit the programming mode.

## Door call to bus handsfree telephone

At the bus handsfree telephone a different ringtone can optionally be selected for the door call. The

volume of the door call can be changed at the bus handsfree telephone.

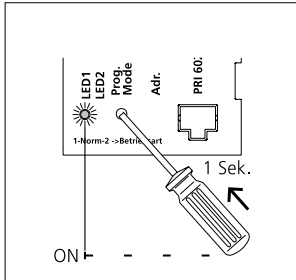

**1** Switch on the programming mode. At the BNG/BVNG 650-..., press the programming mode button briefly. The LED 1 flashes in a 2-second rhythm to indicate that the programming mode is active.

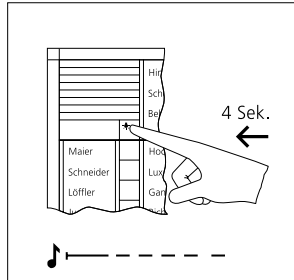

**2** At the door station, hold down the light/programming button for 4 seconds. A prolonged acknowledgement tone is then audible which is repeated every 5 seconds as long as the programming mode remains active.

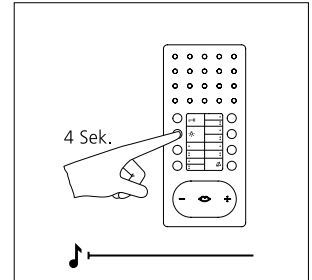

**3** Hold down the light button for 4 seconds. A prolonged acknowledgement tone is audible in the receiver, the muting button flashes. A speech connection exists to the door station. The bus telephone is now in the programming mode.

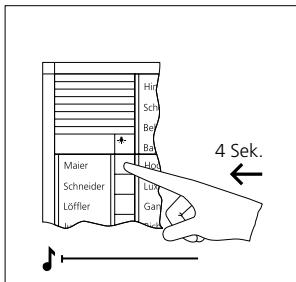

**4** On the door station, press and hold the desired call button for 4 seconds until a sustained tone can be heard from the door loudspeaker. The call button is now assigned to the bus indoor device.

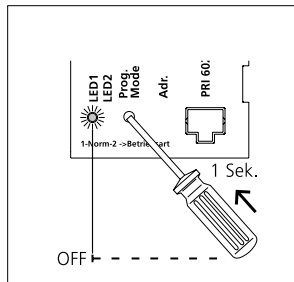

**5** The call button is now firmly assigned to the handsfree bus telephone.

Program additional users using the same procedure or quit the programming mode.

## 7.1 Programming – manual

### Door call via the storey call button

Programming is only possible when the storey call button (ERT) is connected to the bus indoor device.

If there is no access available to an apartment, programming can still be carried out in this way.

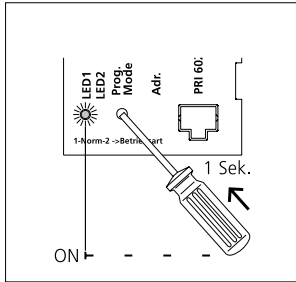

**1** Switch on the programming mode. At the BNG/BVNG 650-..., press the programming mode button briefly. The LED 1 flashes in a 2-second rhythm to indicate that the programming mode is active.

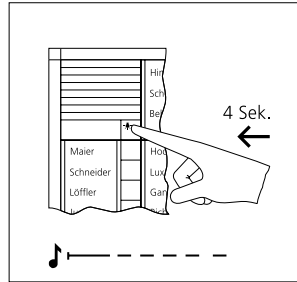

**2** At the door station, hold down the light/programming button for 4 seconds. A protracted acknowledgement tone is then audible which is repeated every 5 seconds as long as the programming mode remains active.

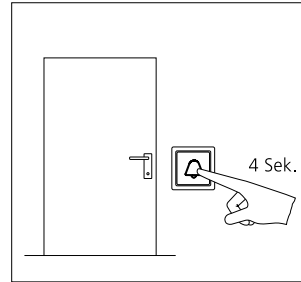

**3** Hold down the storey call button connected to the bus indoor device for 4 seconds. The bus indoor device is now in the programming mode. During this period, no ringing is admissible within the system.

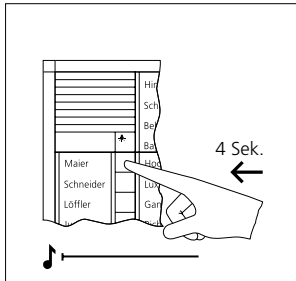

**4** On the door station, press and hold the desired call button for 4 seconds until a sustained tone can be heard from the door loudspeaker. The call button is now assigned to the bus indoor device.

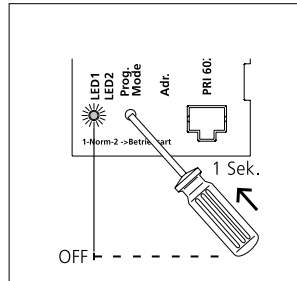

**5** The call button is now firmly assigned to the bus indoor devices. Program additional users using the same procedure or quit the programming mode.

## Parallel door call

Where a door call has to be signalled at several bus telephones simultaneously.

Using the manual programming method, 2 bus indoor devices can be programmed in parallel.

For more information, see page 88

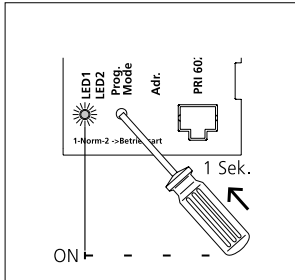

**1** Switch on the programming mode. At the BNG/BVNG 650-..., press the programming mode button briefly. The LED 1 flashes in a 2-second rhythm to indicate that the programming mode is active.

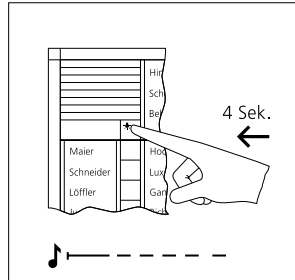

**2** At the door station, hold down the light/programming button for 4 seconds. A protracted acknowledgement tone is then audible which is repeated every 5 seconds as long as the programming mode remains active.

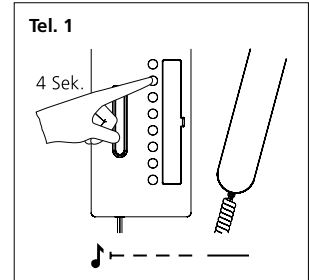

**3** Lift the receiver at the bus telephone which you wish to program. Hold down the light button for 4 seconds. A protracted signal tone is audible in the receiver. A speech connection exists to the door station. The bus telephone is now in the programming mode. Do not replace the receiver!

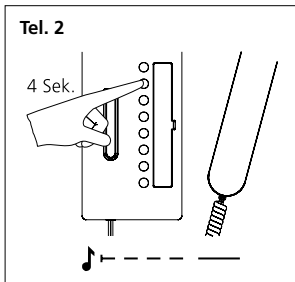

**4** Lift the receiver at the second bus telephone which you wish to program. Hold down the light button for 4 seconds. Do not replace the receiver! Perform the same procedure in all other bus telephones.

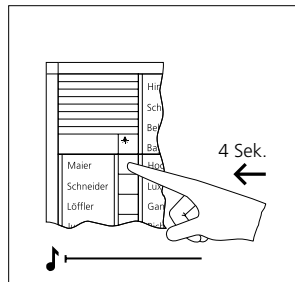

**5** On the door station, press and hold the desired call button for 4 seconds until a sustained tone can be heard from the door loudspeaker. The call button is now assigned to the bus indoor device.

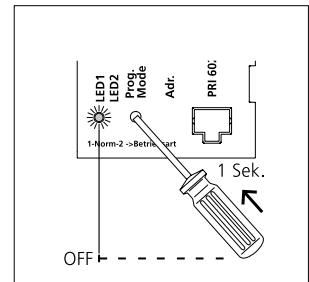

**6** Replace the receiver at all bus telephones which have been programmed. The call button is now firmly assigned to all bus telephones. Program additional users using the same procedure or quit the programming mode.

## 7.1 Programming – manual

### Internal call

You wish a bus telephone to be able to call and communicate with another bus telephone in the system. The muting and light buttons of the

bus telephone can be reprogrammed if required for internal call functions. With the deluxe bus telephone up to 7 other bus telephones can be called.

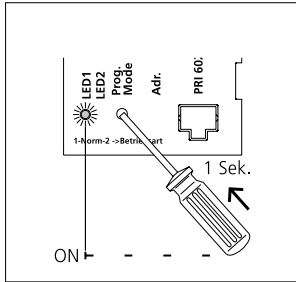

**1** Switch on the programming mode. At the BNG/BVNG 650-..., press the programming mode button briefly. The LED 1 flashes in a 2-second rhythm to indicate that the programming mode is active.

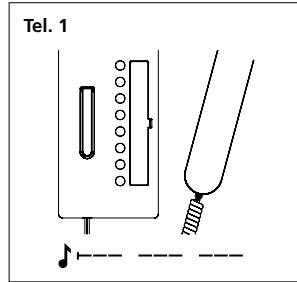

**2** Lift the receiver at the first bus telephone you wish to enable for internal calls. The programming mode tone is audible.

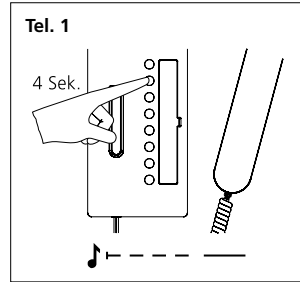

**3** Hold the light button down for 4 seconds. The acknowledgement tone is audible. Do not replace the receiver.

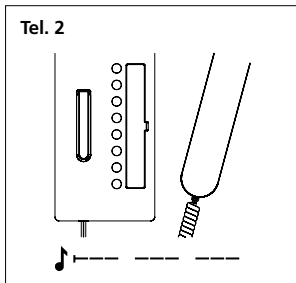

**4** Lift the receiver at the second bus telephone you wish to enable for internal calls. The programming mode tone is audible.

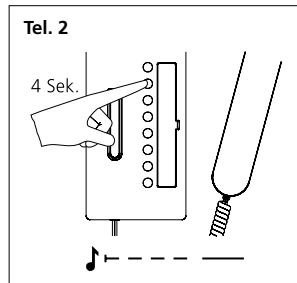

**5** Hold the light button down for 4 seconds. The acknowledgement tone is audible. Do not replace the receiver.

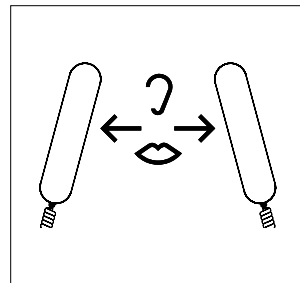

**6** A speech connection now exists between the two bus telephones.

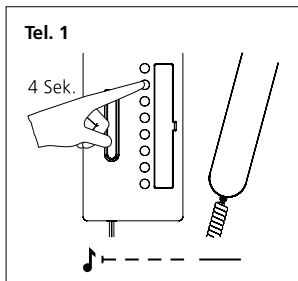

**7** At the first bus telephone, hold down the internal call button you wish to use to call the second bus telephone for 4 seconds. A protracted tone is audible. The bus telephone is now programmed. Do not yet replace the receiver.

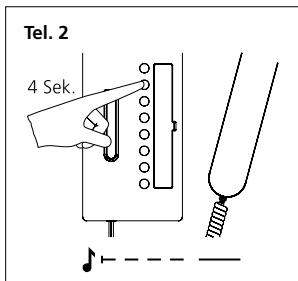

**8** At the second bus telephone, hold down the internal call button you wish to use to call the first bus telephone for 4 seconds. A protracted tone is audible. The buttons are now programmed at both bus telephones.

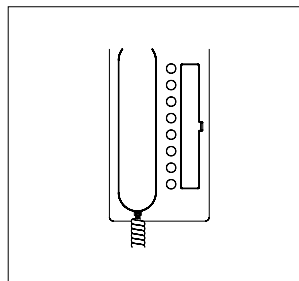

**9** Replace the receiver at both bus telephones. Program additional bus telephones using the same procedure or quit the programming mode.

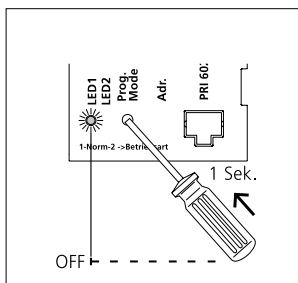

**10** Switch off the programming mode at the BNG/BVNG 650-...

## 7.1 Programming – manual

### Dialling the door station

You wish to be able to call one or more door stations from a bus telephone using buttons, e.g. in order to selectively speak to a visitor.

This function can be programmed for any bus telephone to any button. The only exception is the door release button.

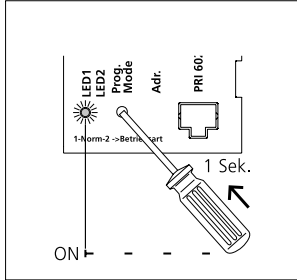

**1** Switch on the programming mode. At the BNG/BVNG 650-..., press the programming mode button briefly. The LED 1 flashes in a 2-second rhythm to indicate that the programming mode is active.

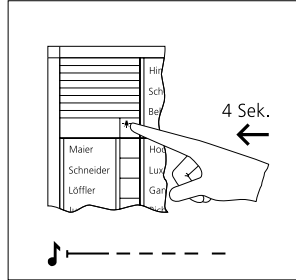

**2** At the door station, hold down the light/programming button for 4 seconds. A protracted acknowledgement tone is then audible which is repeated every 5 seconds as long as the programming mode remains active.

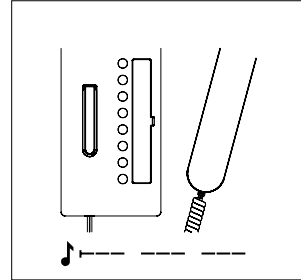

**3** Lift the receiver at the bus telephone which you wish to program.

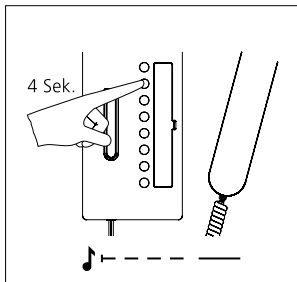

**4** Hold down the light button for 4 seconds. A protracted acknowledgement tone sounds in the receiver, the muting button flashes. A speech connection exists to the door station. The bus telephone is now in the programming mode. Leave the receiver off the hook.

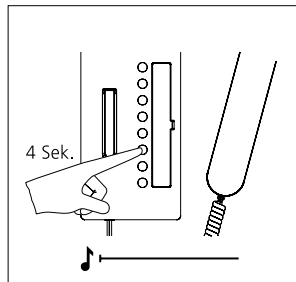

**5** At the bus telephone, hold down the button you wish to use to call the door station for 4 seconds. Replace the receiver. The button is now assigned to the door station. The door loudspeaker can be dialled at any time.

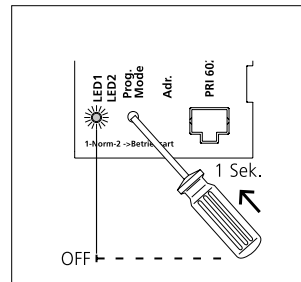

**6** Replace the receiver. Continue to program more bus telephones or quit the programming mode.



## Call differentiation of 2 door stations

At the bus telephone you wish to be able to tell at which door the door call has been made, e.g. whether a door call has come from the main entrance or a side entrance.

Call differentiation can take place from max. 2 doors.

Door call 1 = Tone sequence 1

Door call 2 = Tone sequence 2

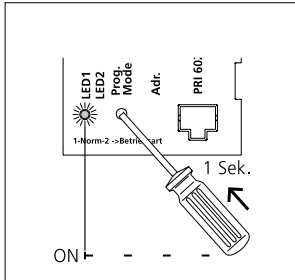

**1** Switch on the programming mode. At the BNG/BVNG 650-..., press the programming mode button briefly. The LED 1 flashes in a 2-second rhythm to indicate that the programming mode is active.

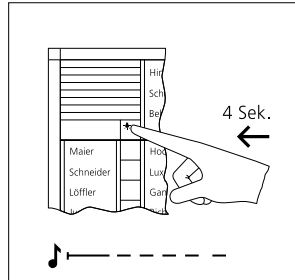

**2** At the door station, hold down the light/programming button for 4 seconds. A protracted acknowledgement tone is then audible which is repeated every 5 seconds as long as the programming mode remains active.

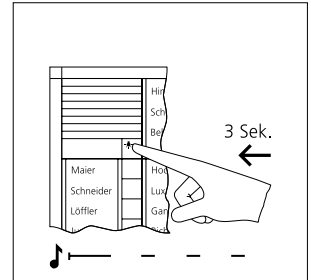

**3** Hold down the light/programming button again for 3 seconds. A short acknowledgement tone is audible. At the bus telephones, a different tone sequence is audible when a call is placed by this door station.

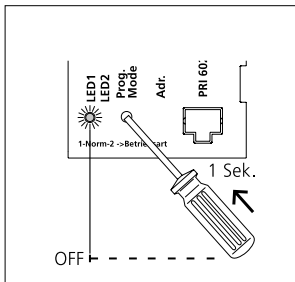

**4** Switch off the programming mode at the BNG/BVNG 650-...

## 7.1 Programming – manual

### Additional contact on the BSM 650-...

In addition to an already programmed bus telephone, you wish a potential-free switching contact to be closed when a door call is placed.

Actuation of an additional bell or lamp on placement of a door call.

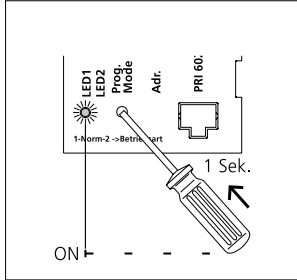

**1** Switch on the programming mode. At the BNG/BVNG 650-..., press the programming mode button briefly. The LED 1 flashes in a 2-second rhythm to indicate that the programming mode is active.

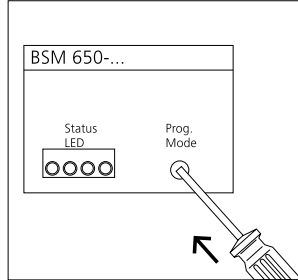

**2** Switch the BSM 650-... to the programming mode. To do this, briefly press the programming mode button using a small screwdriver. LED 1 lights up and flashes slowly after appr. 3 seconds.

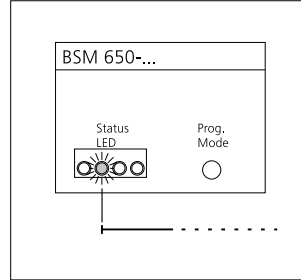

**3** Select the relevant relay by actuating the Prog. mode button at the BSM 650-... with a screwdriver until the required LED lights up (LED2 = relay2, press 2x).

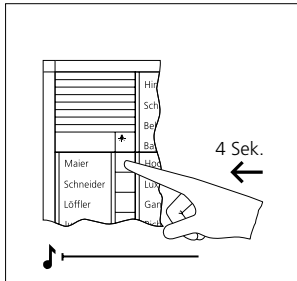

**4** Press the button to which you wish the relay to be assigned and hold down for 4 seconds. A protracted acknowledgement tone is audible in the receiver.

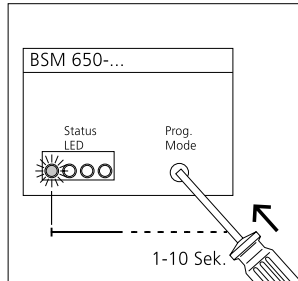

**5** The switching time for the contact is determined by the time for which the screwdriver is held down.

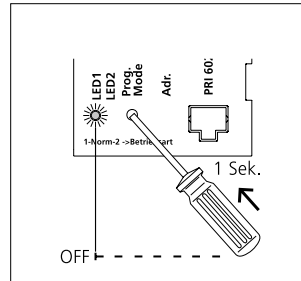

**6** Continue to program more control buttons or quit the programming mode.

## Button of a bus telephone on the BSM 650-...

Actuation of a contact in the BSM 650-..., e.g. in order to open a garage or switch on a staircase light.

Using the bus programming software BPS 650-... the switching function/time can now be changed.

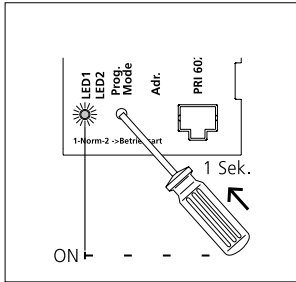

**1** Switch on the programming mode. At the BNG/BVNG 650-..., press the programming mode button briefly. The LED 1 flashes in a 2-second rhythm to indicate that the programming mode is active.

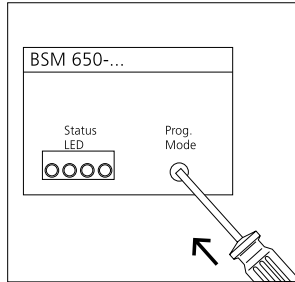

**2** Switch the BSM 650-... to the programming mode. To do this, briefly press the programming mode button using a small screwdriver. LED 1 lights up and flashes slowly after approx. 3 seconds.

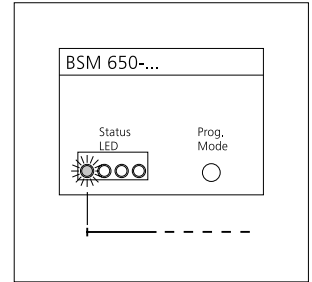

**3** Select the relevant relay by actuating the programming mode button at the BSM 650-... with the screwdriver until the required LED lights up (LED 1=relay 1).

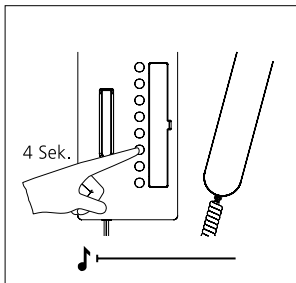

**4** Lift the receiver at the bus telephone at which you wish to program a button. Press the button you wish to program and hold down for 4 seconds. A protracted acknowledgement tone is audible in the receiver.

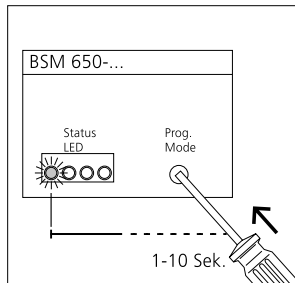

**5** The switching time for the contact is determined by the time for which the screwdriver is held down.

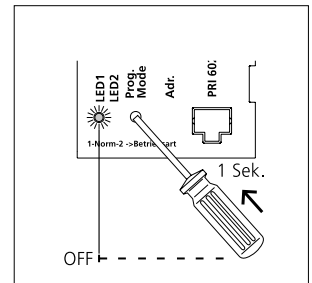

**6** Continue to program more control buttons or quit the programming mode.

## 7.1 Programming – manual

### Deleting the assignment on the BSM 650-...

The assignments on the bus switching module can be deleted in delete mode.

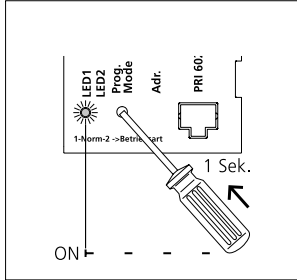

**1** Switch on the programming mode. At the BNG/BVNG 650-..., press the programming mode button briefly. The LED 1 flashes in a 2-second rhythm to indicate that the programming mode is active.

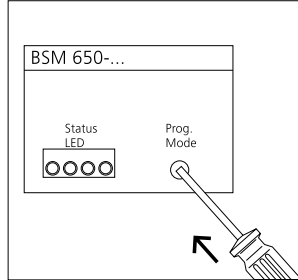

**2** Switch the BSM 650-... to the programming mode. To do this, briefly press the programming mode button using a small screwdriver. LED 1 lights up and flashes slowly after appr. 3 seconds.

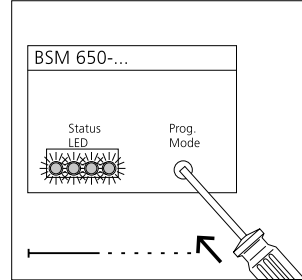

**3** Activate delete mode, to do so press the programming mode button on the BSM 650-... with the screwdriver until all four LEDs light up for 3 seconds and then flash.

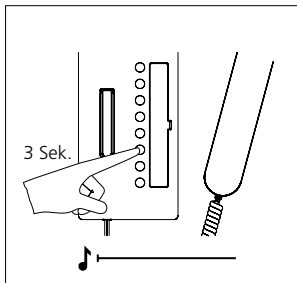

**4** Pick up the receiver on the bus telephone and press the button for which the control function is to be deleted for 3 seconds.

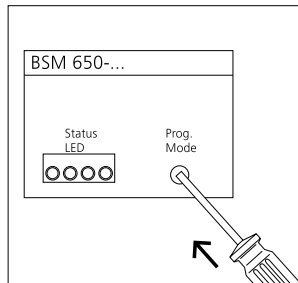

**5** Switch off delete mode on the BSM 650-...

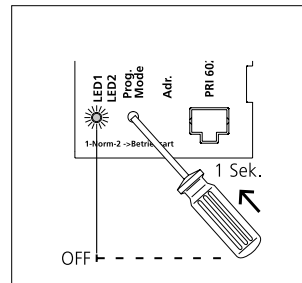

**6** Switch off the programming mode at the BNG/BVNG 650-...



## 7.1 Programming – manual

### Parallel door call to BSE 650-...

The bus telephone must already be programmed to the call button.

Potential-free switching contact which is closed on placement of a door call. Actuation of e.g. a battery-operated chime or additional bell on placement of a door call.

Due to the structure design, the BSE 650-... can be mounted in a 70 junction box.

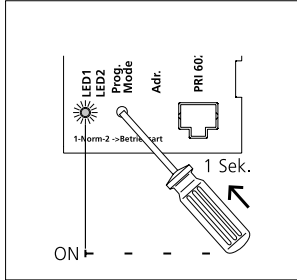

**1** Switch on the programming mode. At the BNG/BVNG 650-..., press the programming mode button briefly. The LED 1 flashes in a 2-second rhythm to indicate that the programming mode is active.

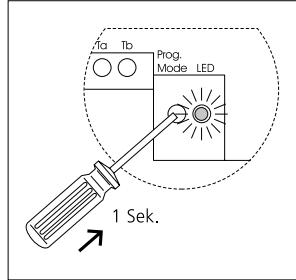

**2** Switch the BSE 650-... to the programming mode. To do this, briefly press the programming mode button with a small screwdriver. The LED flashes slowly.

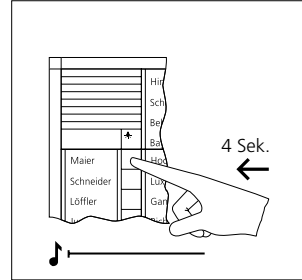

**3** At the door station, press the call button you wish to be assigned to the BSE 650-... An assignment to one or more bus telephones must exist.

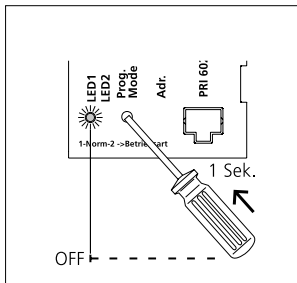

**4** Program additional users using the same procedure or quit the programming mode.

## Door call to BSE 650-...

Potential-free switching contact which is closed on placement of a door call. Due to the structure design, the BSE 650-... can be mounted in a 70 junction box.

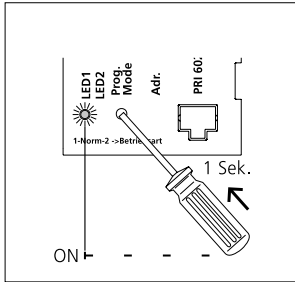

**1** Switch on the programming mode. At the BNG/BVNG 650-..., press the programming mode button briefly. The LED 1 flashes in a 2-second rhythm to indicate that the programming mode is active.

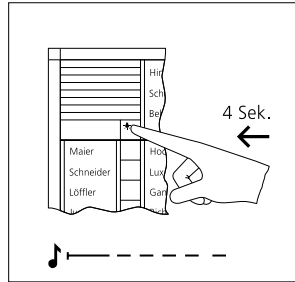

**2** At the door station, hold down the light/programming button for 4 seconds. A protracted acknowledgement tone is then audible which is repeated every 5 seconds as long as the programming mode remains active.

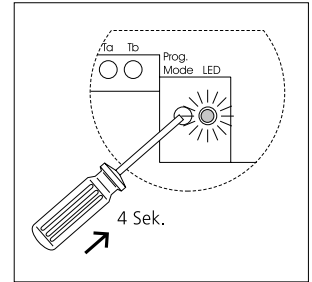

**3** Switch the BSE 650-... to the programming mode. To do this, briefly press the programming mode button with a small screwdriver. The LED flashes slowly.

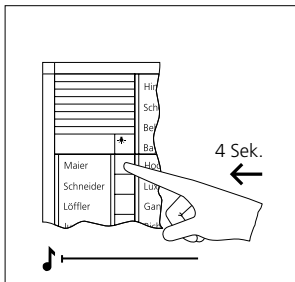

**4** At the door station, press the call button you wish to be assigned to the BSE 650-...

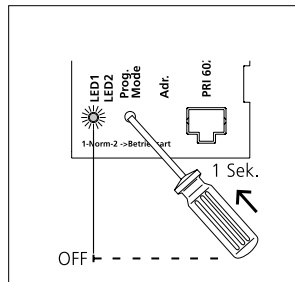

**5** Switch off the programming mode at the BNG/BVNG 650-...

## 7.1 Programming – manual

Button of a bus telephone on the BSE 650-...

Actuation of additional functions such as switching on the staircase light or garage door OPEN/SHUT. Switching time with manual programming 1 second.

Using the bus programming software BPS 650-... the switching function/time can now be changed.

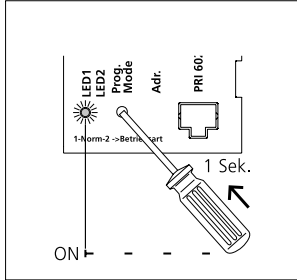

**1** Switch on the programming mode. At the BNG/BVNG 650-..., press the programming mode button briefly. The LED 1 flashes in a 2-second rhythm to indicate that the programming mode is active.

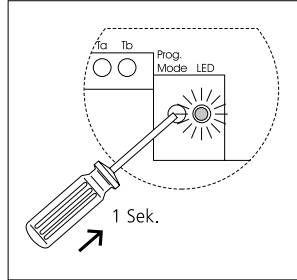

**2** Switch the BSE 650-... to the programming mode. To do this, briefly press the programming mode button with a small screwdriver. The LED flashes slowly.

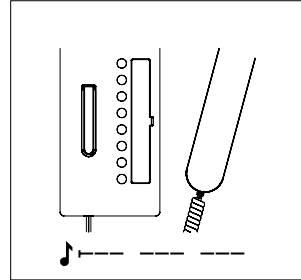

**3** Lift the receiver at the bus telephone at which you wish to program a button.

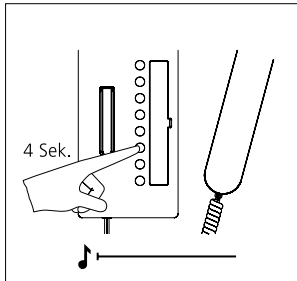

**4** Press the button you wish to program and hold down for 4 seconds. A protracted acknowledgement tone is audible in the receiver. The switching contact of the BSE 650-... is closed for 1 second.

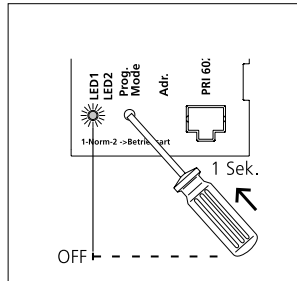

**5** Program additional users using the same procedure or quit the programming mode.



## Bus secondary signal unit BNS 750-...

Signal device to additionally indicate the door call and/or storey call in another room.

Where there are several doors, the same programming sequence must

be used every time.

For activating an indoor device (switching to the programming mode).

For more information, see page 55

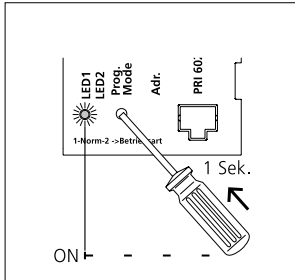

**1** Switch on the programming mode. At the BNG/BVNG 650-..., press the programming mode button briefly. The LED 1 flashes in a 2-second rhythm to indicate that the programming mode is active.

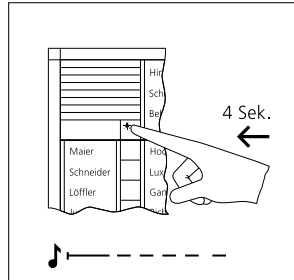

**2** At the door station, hold down the light/programming button for 4 seconds. A protracted acknowledgement tone is then audible which is repeated every 5 seconds as long as the programming mode remains active.

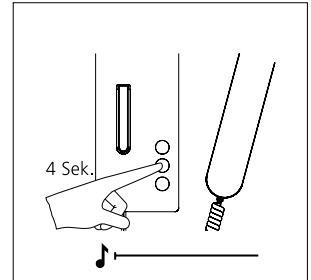

**3** Hold down the light button for 4 seconds. A protracted acknowledgement tone sounds in the receiver, the muting button flashes. A speech connection exists to the door station. The bus telephone is now in the programming mode. Leave the receiver off the hook.

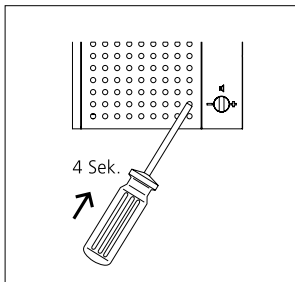

**4** Hold down the programming button of the bus secondary signal unit through the opening in the louvre for 4 seconds. A brief acknowledgement tone is audible.

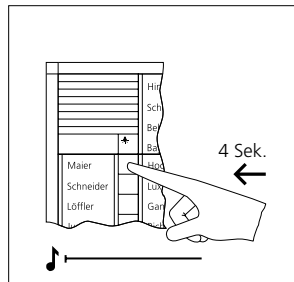

**5** At the door station, hold down the required call button for 4 seconds until a protracted tone sounds at the door loudspeaker. Both users are programmed to this call button.

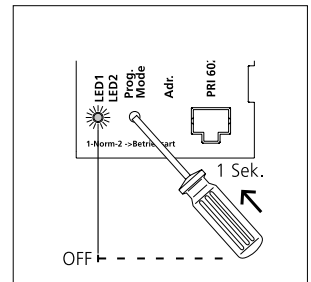

**6** Replace the receiver. Continue to program more bus telephones or quit the programming mode.

## 7.1 Programming – manual

Call via DRM 612-...

Bus telephones are called from the door station via the display call module DRM 612-...

The names in the display call module DRM 612-... must be assigned already prior to the start of user programming. Names are entered at a PC using the programming

software PRS 602-... For connection of the PC to the DRM 612-... the programming interface PRI 602-... is required.

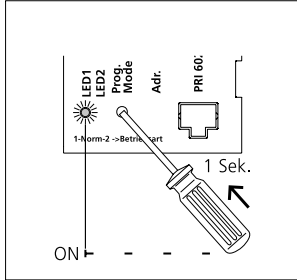

**1** Switch on the programming mode. At the BNG/BVNG 650-..., press the programming mode button briefly. The LED 1 flashes in a 2-second rhythm to indicate that the programming mode is active.

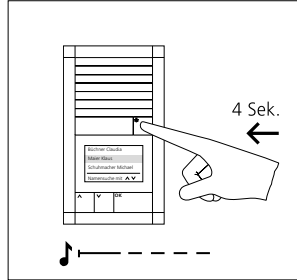

**2** At the door station, hold down the light/programming button for 4 seconds. A prolonged acknowledgement tone is then audible which is repeated every 5 seconds as long as the programming mode remains active.

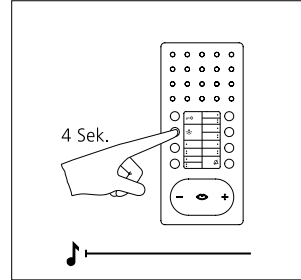

**3** Hold down the light button for 4 seconds. A prolonged acknowledgement tone is audible in the receiver, the muting button flashes. A speech connection exists to the door station. The bus telephone is now in the programming mode.

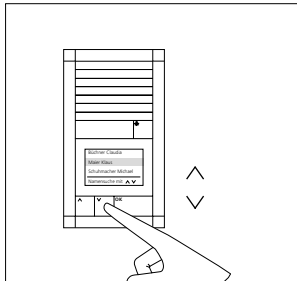

**4** At the door station, select the required name using the two arrow buttons.

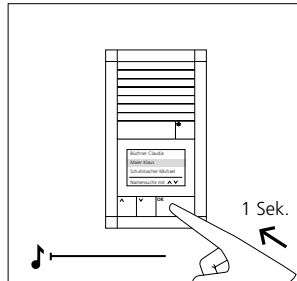

**5** When the selected name is shown on the display, press the OK button on the DRM 612-..., a protracted tone can be heard at the door loudspeaker. The selected name is now assigned to the bus indoor device. The speech connection is interrupted. If the name was already programmed, the OK button must be pressed twice.

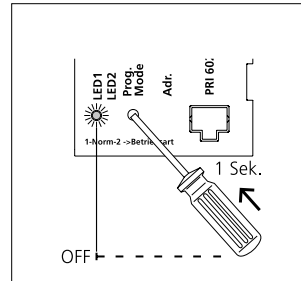

**6** Program additional users using the same procedure or quit the programming mode.

## Call via COM 611-...

Bus telephones are called by the door station via the COM 611-... code lock module.

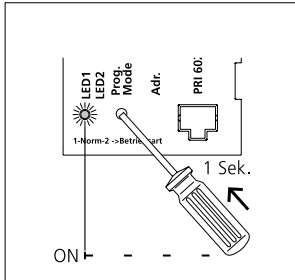

**1** Switch on the programming mode. At the BNG/BVNG 650-..., press the programming mode button briefly. The LED 1 flashes in a 2-second rhythm to indicate that the programming mode is active.

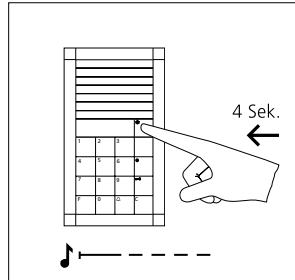

**2** At the door station, hold down the light/programming button for 4 seconds. A prolonged acknowledgement tone is then audible which is repeated every 5 seconds as long as the programming mode remains active.

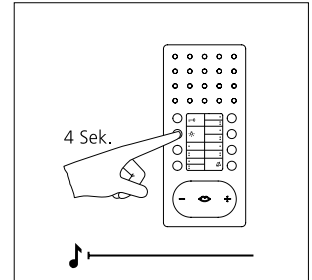

**3** Hold down the light button for 4 seconds. A prolonged acknowledgement tone is audible in the receiver, the muting button flashes. A speech connection exists to the door station. The bus telephone is now in the programming mode.

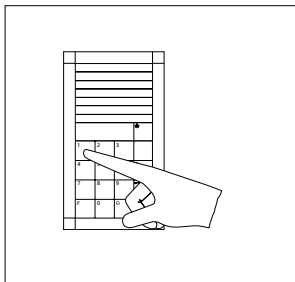

**4** Enter the required 1-8 digit (1-9999999) call number at the door station.

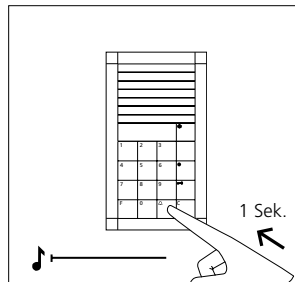

**5** Once the required digit has been entered, hold down the button with the bell symbol on the COM 611-..., a protracted tone can be heard at the door loudspeaker. The selected call number is now assigned to the bus indoor device. The speech connection is interrupted.

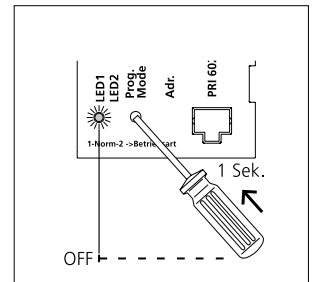

**6** Program additional users using the same procedure or quit the programming mode.

At the Jung indoor station, a different ringtone can optionally be selected for the door call.

The volume of the door call can be changed at the Jung indoor device.

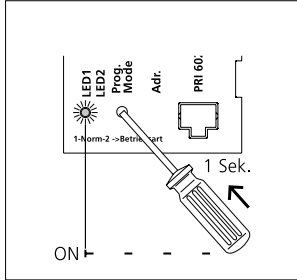

**1** Switch on the programming mode. At the BNG/BVNG 650-..., press the programming mode button briefly. The LED 1 flashes in a 2-second rhythm to indicate that the programming mode is active.

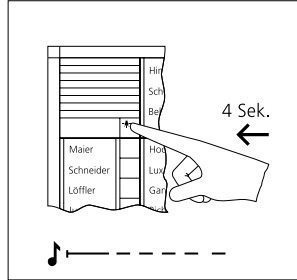

**2** At the door station, hold down the light/programming button for 4 seconds. A protracted acknowledgement tone is then audible which is repeated every 5 seconds as long as the programming mode remains active.

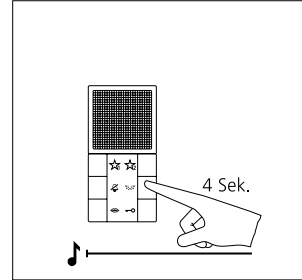

**3** Hold down the light button for 4 seconds. A protracted acknowledgement tone sounds as confirmation and the muting button begins to flash. The audio indoor station establishes the speech connection to the door station. The audio indoor station is now in the programming mode.

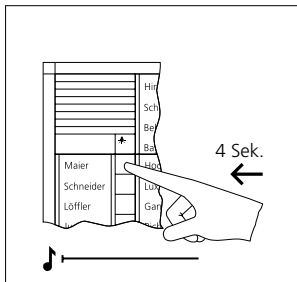

**4** On the door station, press and hold the desired call button for 4 seconds until a sustained tone can be heard from the door loudspeaker. The call button is now assigned to the bus indoor device.

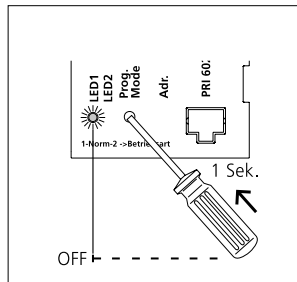

**5** The call button is now firmly assigned to the audio indoor station. Program additional users using the same procedure or quit the programming mode.

## Parallel door call to Jung indoor station

A door call has to be signalled at several Jung indoor stations simultaneously.

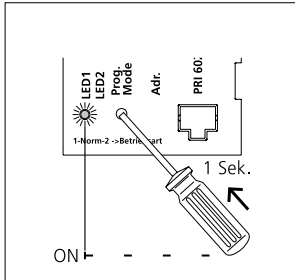

**1** Switch on the programming mode. At the BNG/BVNG 650-..., press the programming mode button briefly. The LED 1 flashes in a 2-second rhythm to indicate that the programming mode is active.

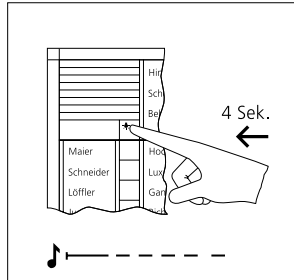

**2** At the door station, hold down the light/programming button for 4 seconds. A protracted acknowledgement tone is then audible which is repeated every 5 seconds as long as the programming mode remains active.

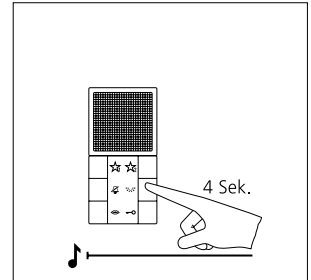

**3 Audio indoor station 1:** Hold down the light button for 4 seconds. A protracted acknowledgement tone sounds as confirmation and the muting button begins to flash. The audio indoor station establishes the speech connection to the door station. The audio indoor station is now in the programming mode.

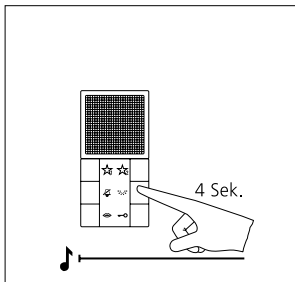

**4 Audio indoor station 2:** Hold down the light button for 4 seconds. A protracted acknowledgement tone sounds as confirmation and the muting button begins to flash. The audio indoor station establishes the speech connection to the door station. The audio indoor station is now in the programming mode.

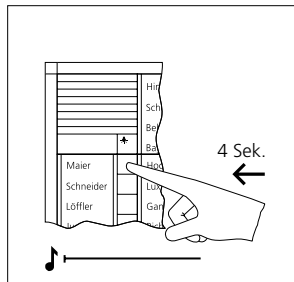

**5** On the door station, press and hold the desired call button for 4 seconds until a sustained tone can be heard from the door loudspeaker. The call button is now assigned to the bus indoor device.

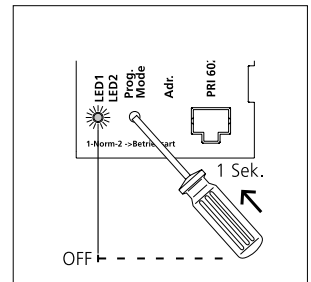

**6** The call button is now firmly assigned to the audio indoor station. Program additional users using the same procedure or quit the programming mode.

## 7.1 Programming – manual

### Internal call between Jung indoor stations

You wish a Jung indoor station to be able to call and communicate with another Jung indoor station in the system.

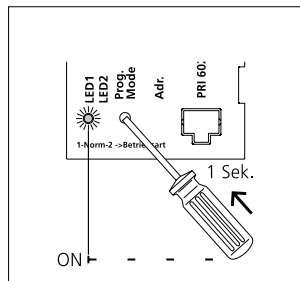

**1** Switch on the programming mode. At the BNG/BVNG 650-..., press the programming mode button briefly. The LED 1 flashes in a 2-second rhythm to indicate that the programming mode is active.

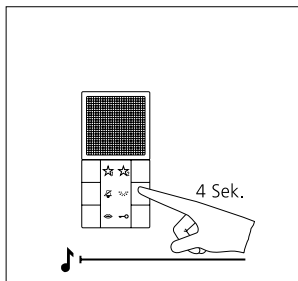

**2 Audio indoor station 1:** Hold down the light button for 4 seconds. A prolonged acknowledgement tone sounds as confirmation and the muting button begins to flash.

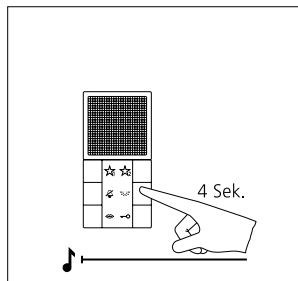

**3 Audio indoor station 2:** Hold down the light button for 4 seconds. A prolonged acknowledgement tone sounds as confirmation and the muting button begins to flash.

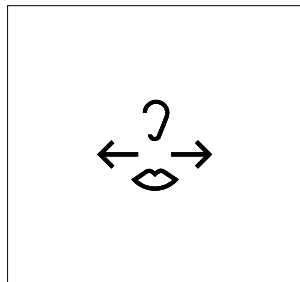

**4** A speech connection now exists between the two audio indoor stations.

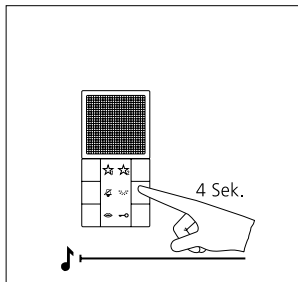

**5 Audio indoor station 1:** Hold down the internal call button you wish to use to call the second device for 4 seconds. A prolonged tone is audible.

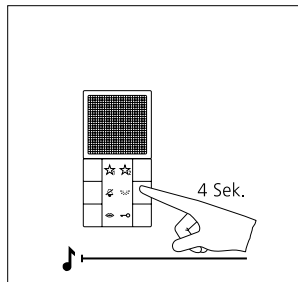

**6 Audio indoor station 2:** Hold down the internal call button you wish to use to call the first device for 4 seconds. A prolonged tone is audible. The buttons are now programmed at both devices.

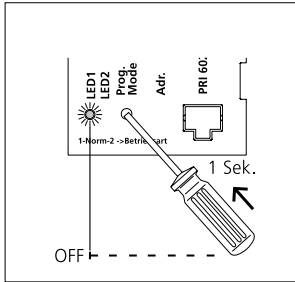

**7** Switch off the programming mode at the BNG/BVNG 650-...

## 7.2 Programming – Plug+Play

### Basics

Plug+Play programming offers the opportunity for those without programming experience to commission an In-Home bus system. The entire installation of all users must have been completed. The  **housings of the bus telephones must not yet have been closed**. The Plug+Play mode must be activated at the bus line rectifier. By being connected to the bus door loudspeaker, the call buttons at the bus call button module are assigned a consecutive number. The bus telephones are subsequently locked onto the base plates in this sequence.

#### Conditions for Plug+Play:

- Plug+play-programming is only possible with new bus indoor devices, new bus door loudspeaker BTLM 650-04/BTLE 050-03, bus call button modules BTM 650-01, -02, -03, -04, BRMA 050-01 and bus line rectifiers BNG/BVNG 650-...
- Plug+play-programming only works for bus indoor devices within any one line.
- Several door stations within a line are programmed simultaneously with the same assignment, e.g. two door stations with 4 call buttons have the same assignment. Where there is more than one bus call button module, numbering of the call buttons takes place in the same sequence in which the modules are connected to each other via the IN/OUT connections.

#### Conditions for Plug+Play:

- Install the system in accordance with the wiring diagram.
- Connect the base plates of the bus telephones, **do not yet close the housings**.
- Connect the Jung modules to each other using the supplied connecting cables. The terminal block must **not yet** be plugged in.
- At the door station, document the assignment of call buttons or if possible inscribe straight away.
- Set the bus line rectifier to the Plug+Play mode by holding down the programming mode button for 5 seconds. LED 1 must stay on continuously.
- Mount the bus telephones on the base plates in the same sequence as the assignment of call buttons. (receiver down)
- Where a Jung indoor station is used, plug in the terminal block.
- The storey call is audible briefly after appr. 7 seconds as an acknowledgement and the LED under the call silencing button starts to flash. The next bus telephone can then be closed.
- After all the telephones have been closed, at the bus line rectifier press the programming mode button. The programming mode is switched off, the programming of the system is complete.

#### Reset Plug+Play:

- All already connected bus telephones must be locked into position on the base plates.
- Switch off the supply voltage to the bus line rectifier.
  - Disconnect terminals Ta and Tb
  - Change the address of the bus line rectifier, e.g. from address 1 to address 2
  - Hold down the Prog. mode button for around 3 seconds and switch on the supply voltage of the bus line rectifier. After around 3 seconds release the button, wait until LED 1 indicates the standard operating mode again.
  - Reconnect terminals Ta and Tb and wait until the system has finished running up.
  - Pick up all bus telephones from the base plates again.
  - Return the address switch to its original status, e.g. change from 2 to 1, and wait until the system has finished running up. Check whether all the bus telephones have been picked up again. Plug+Play programming can begin again.



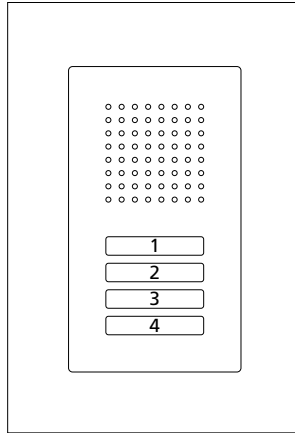
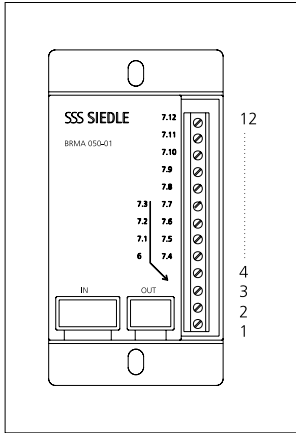

**Bus custom-fit door loudspeaker**

The sequence of terminals on the bus call button matrix corresponds to the sequence of bus telephones.

Terminal 7.1 = Bus telephone 1  
etc.

Terminal 7.12 = Bus telephone 12

**Siedle Classic**

The sequence of terminals on the bus call button matrix corresponds to the sequence of bus telephones.

The uppermost button is button 1, remaining buttons follow in consecutive sequence.

Terminal 7.1 = Bus telephone 1  
etc.

Terminal 7.4 = Bus telephone 4

Assignment of bell buttons:

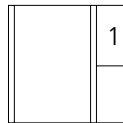

BTM 650-01

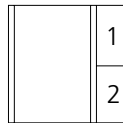

BTM 650-02

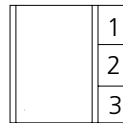

BTM 650-03

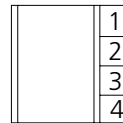

BTM 650-04

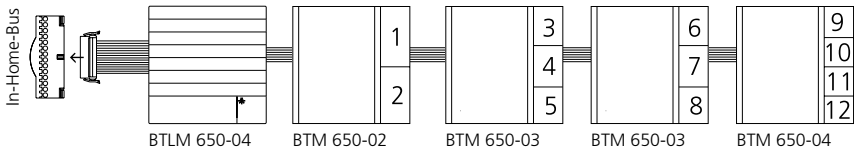

## 7.2 Programming – Plug+Play

Example of a 4-family home

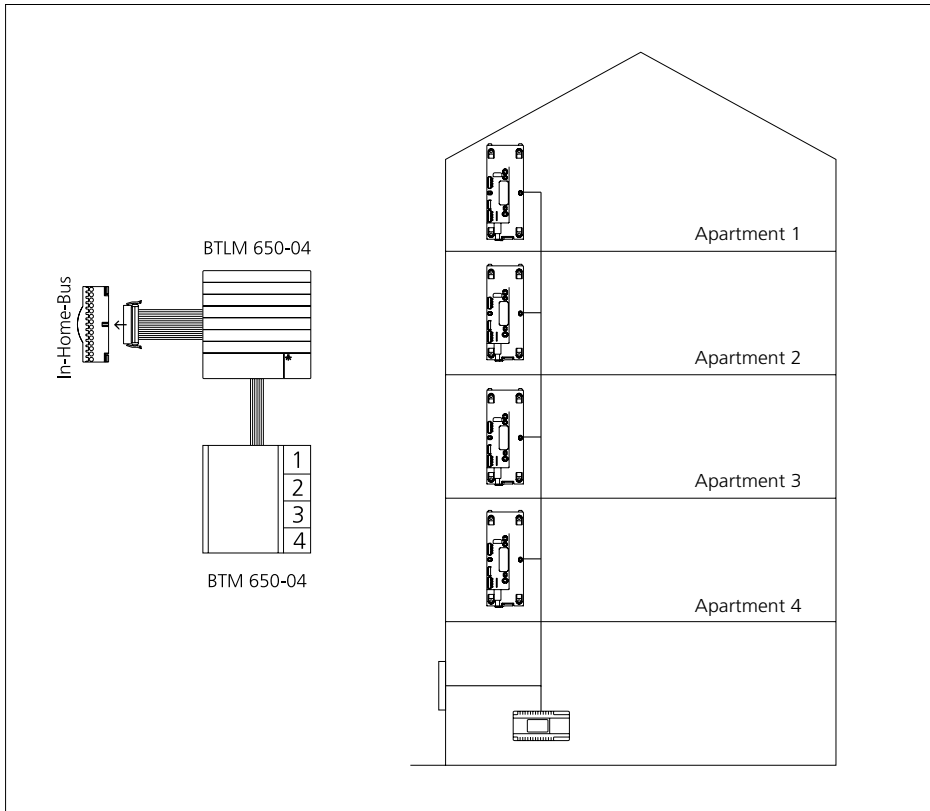

### Restrictions

- Bus telephones which are already assigned to a door loudspeaker in the same line are not reprogrammed.
- Bus telephones which are already programmed in a different line are reassigned to a bell button.
- Call buttons of the BTLM/BTLE are disabled during Plug+Play programming, no inputs can be made.
- Plug+Play programming can be continued in an existing system. The next free call button is assigned.
- Bus telephones which you wish to ring in parallel or devices for switching and control functions must be programmed manually or via the PC and BPS 650-... This step can also be performed at a later stage.

### Possible errors

- If unsuitable devices log in during Plug+Play programming (old bus telephone models such as BTS/ BTC 750-... or BSM etc.) the configuration is aborted and an error signal sent to fault LED 2 at the BNG/BVNG 650-...
- If door bell buttons have been assigned to the wrong bus telephones during Plug+Play programming, the BNG/BVNG 650-... must be restored to as-delivered status and Plug+Play programming repeated. Alternatively it is possible to overwrite the bus telephones using manual programming.

## Procedure – Example

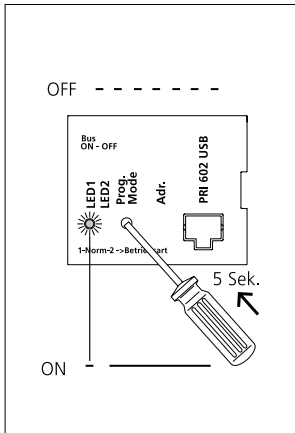

**1** Activate the Plug+Play-mode at the BNG/BVNG 650-..., hold down the programming mode button for 5 seconds. LED 1 lights up permanently.

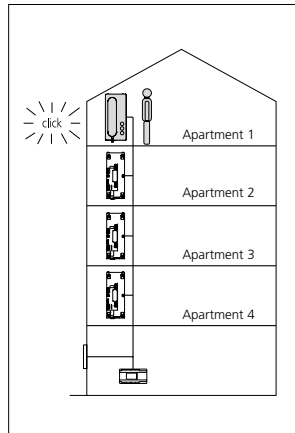

**2** Set up the bus telephone in apartment 1 with the receiver in place, the storey call sounds as an acknowledgement tone and the LED of the muting button flashes. Bus telephone 1 is assigned to button 1.

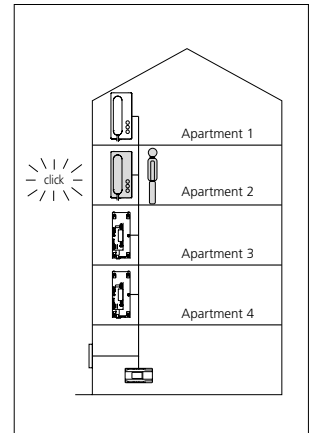

**3** Set up the bus telephone in apartment 2 with the receiver in place, the storey call sounds as an acknowledgement tone and the LED of the muting button flashes.

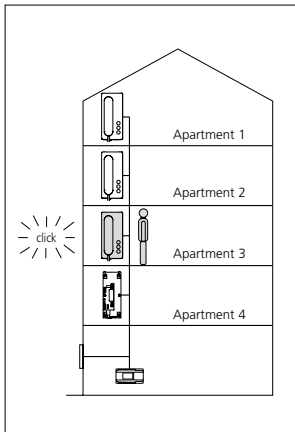

**4** Set up the bus telephone in apartment 3 with the receiver in place, the storey call sounds as an acknowledgement tone and the LED of the muting button flashes.

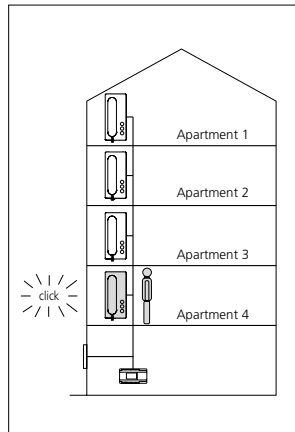

**5** Set up the bus telephone in apartment 4 with the receiver in place, the storey call sounds as an acknowledgement tone and the LED of the muting button flashes.

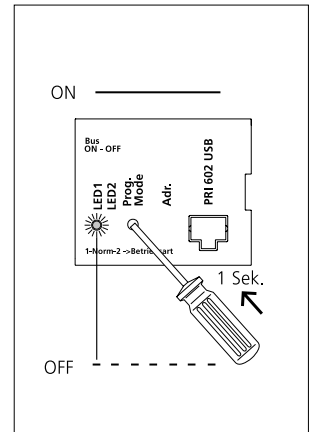

**6** Switch off the Plug+Play-mode at the BNG/BVNG 650-... by briefly pressing the programming mode key. The LED 1 at the BNG/BVNG 650-... now flashes again to indicate normal operation. All LEDs at the bus telephones are off, the system is ready for operation.

### 7.3 Programming – with PC

#### BPS 650-... and PRI 602-... USB

Using bus programming software BPS 650-... the entire function of an In-Home system can be programmed using a Windows PC. For connection of the PC to the In-Home installation, the programming interface PRI 602-... USB and the bus power supply accessory ZBVG 650-... are required. The ZBVG 650-... is plugged once within a system and once in a BNG/BVNG 650-.... The PRI 602-... USB can be permanently installed in a system or can be plugged in via an 8-pin Western junction box. Current updates for the BPS 650-... software are available in the download area under [www.siedle.com](http://www.siedle.com). For more information on how to commission the system using the Bus programming software BPS 650-... refer to the software online help.

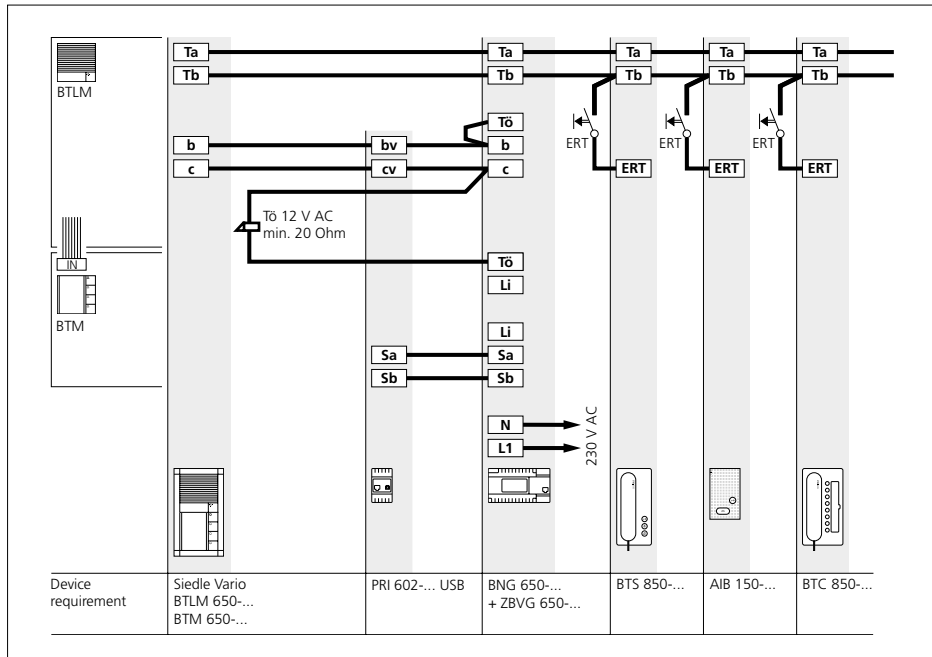
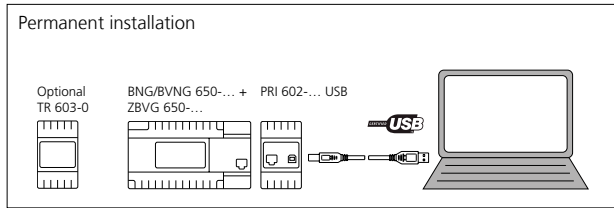
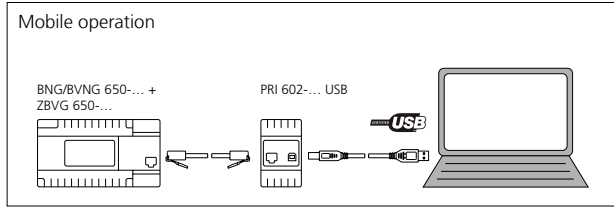

## 8 Supplementary functions

### Switching and control functions

#### Bus switching unit

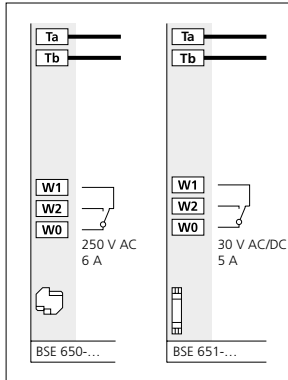

#### Application

- 1 Changeover contact, e.g. for
  - Switching the outside light
  - Opening the garage door
  - Staircase lighting
  - Mounting possible in a 70 junction box
- Switching functions possible with feedback to deluxe bus indoor devices

#### Function

- Switch ON/OFF
- Timer between 0.4 seconds and 19 minutes 59 seconds (as-delivered status)
- Toggle function (status change with each button actuation)
- Secondary signal contact for additional bell
- Supply via In-Home bus

#### Actuation via

- Control buttons of the bus telephones
- Light or call button of a door station
- Bus input module BEM 650-...

#### Programming

Basic switch/timer function by means of manual programming, other functions only using BPS 650-...

#### Bus switching module

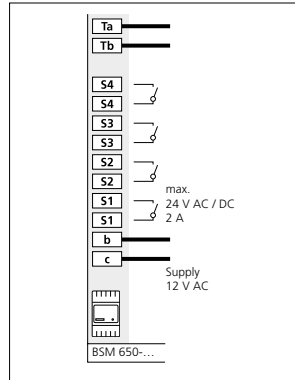

#### Application

- 4 working contacts, e.g. for
  - Switching the outside light
  - Opening the garage door
  - Staircase lighting etc.
  - Mounting on top hat rail

#### Function

- Timer between 0.4 and 12 seconds, switching of an additional door release or gate
- Secondary signal contact for additional bell

#### Actuation via

- Control buttons of the bus telephones
- Light or call button of a door station
- Bus input module BEM 650-...

#### Programming

Manual programming or using BPS 650-...

#### Power supply

Supply with 12 V AC from a BNG 650-... or transformer TR 603-...

#### Bus input module

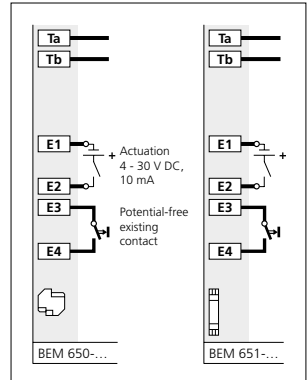

#### Application

- Optical feedback of switching statuses, e.g.
  - Open garage door,
  - Error message heating
  - To actuate the BSE/BSM 650-...
  - Mounting possible in a 70 junction box

#### Function

- Initiation of switching/control functions within the Siedle In-Home bus
- Signal input within the Siedle In-Home bus
- Supply via In-Home bus.

#### Actuation via

Potential-free button or Direct voltage 4-30 V DC

#### Programming

Function can only be programmed using BPS 650-... software

## 8 Supplementary functions

### Door release actuation

In deviation from the standard plans, the door release can be actuated in various ways. The bus line rectifier BNG/BVNG 650-... has a DR contact which is closed every time the door release button is actuated. At the door loudspeakers BTLM 650-... and BTLE 050-... there is also a door release contact which is only closed when the bell has previously been rung at the relevant door loudspeaker. If several door loudspeakers

are operated within a system, both contacts are required to open the door station. In general, high-resistance door releases must be used in order to guarantee the greatest possible degree of operating reliability/ the greatest possible range. Use a Siedle door release or a 12 V AC door release with an impedance of at least 20 Ohm.

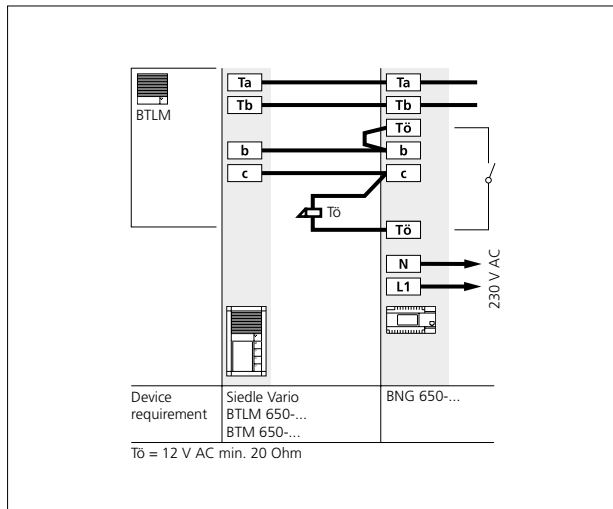

#### Application

Externally positioned door stations  
The door release contact (DR contact) at the bus line rectifier switches every time the door release button is pressed.

#### Benefits

- Tamper-proof, no access from the outside
- Only 4 cores to the door station

#### Drawbacks

- The door release must be routed to the distributor
- Installation only possible with 1 door station in the line
- With several door stations, this installation is not possible

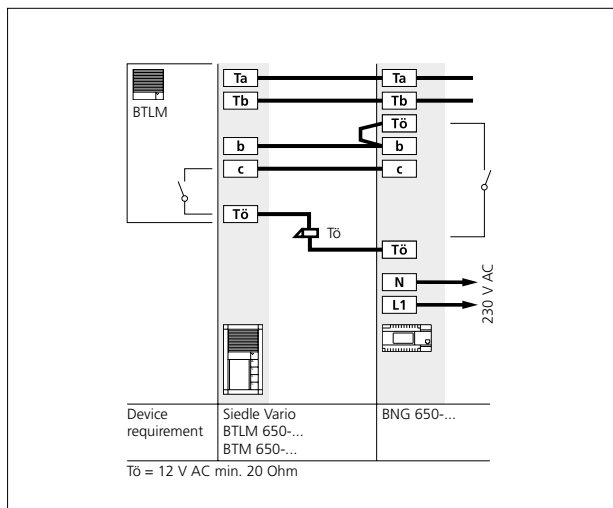

#### Application

Externally positioned door stations  
The bus line rectifier DR contact and the DR contact in the door loudspeaker are used. Both contacts switch every time the door release button is pressed.

#### Benefits

- Tamper-proof, as no access from the outside
- Tamper-proof door release even with several door stations in a system
- Installation principle possible even with several door stations

#### Drawbacks

- The door release must be routed to the distributor and to the door loudspeaker
- 5 cores required to the door station

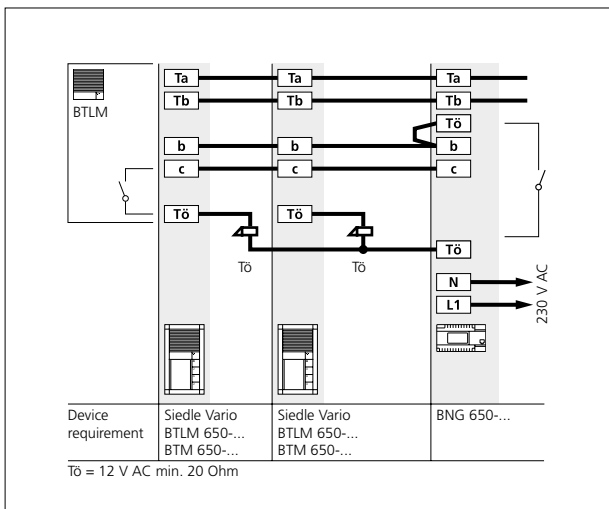

### Application

Systems with more than one door station with door release. The Tö contact (door release contact) in the bus line rectifier and the door release contact in the door loudspeaker are used. The contact in the BNG/BVNG 650-... switches the door release button every time it is pressed, the contact in the door loudspeaker only at the door from which the last door call was placed.

### Benefits

- Tamper-proof, as no access from the outside

### Drawbacks

- The door release must be routed to the distributor
- 5 cores are required to each door station

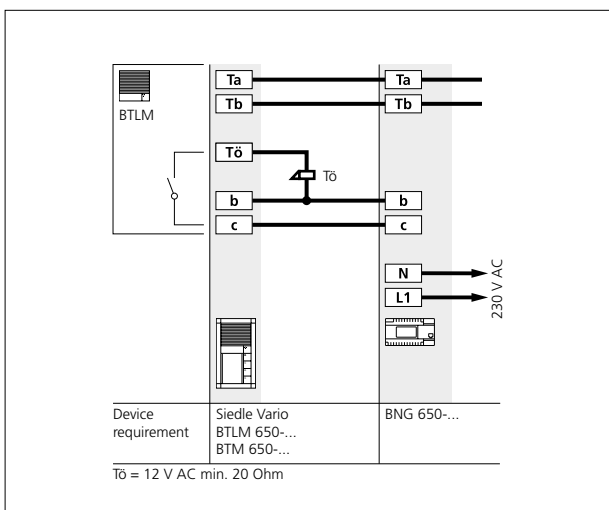

### Application

Garden gate or areas without security relevance. The DR contact in the door loudspeaker switches every time the door release button is pressed.

### Benefits

- Only 4 cores to the door station, the door release is connected directly in the door station
- Several door stations possible without additional installation

### Drawbacks

- Not tamper-proof, as access possible from outside

## 8 Supplementary functions

### Parallel door call

#### Manual programming

In general, 2 telephones can be switched in parallel. Parallel operation can be extended when programming manually to include the deluxe bus telephones BTC/BFC 850-... and auxiliary circuit board ZPS/ZPSF 850-...

#### Programming with PC and BPS

During PC programming, 4 AIB 150-..., BTS/BTC/BFC 850-... units can be programmed in parallel without a supplementary power supply. From the 5th bus telephone, BTC/BFC 850-... units with supplementary power supply via ZPS/ZPSF 850-... are essential.

In case of manual programming only 2 bus telephones can be programmed in parallel without ZPS 850-... When programming using BPS 650-... 4 bus telephones can be programmed in parallel without ZPS/ZPSF 850-... For more information, see page 89

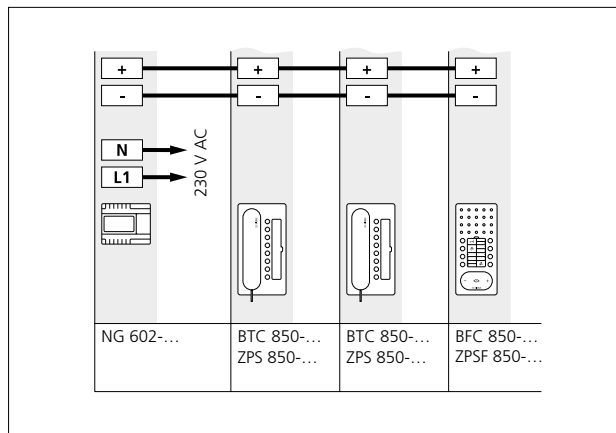

A maximum of 3 ZPS/ZPSF 850-... units can be supplied by a line rectifier NG 602-... The maximum current of the 23.3 V DC direct voltage of the NG 602-... is 300 mA. The specified ranges only apply to the external power supply to the devices, not to the range of the In-Home bus. Ranges applicable for J-Y(St)Y or YR installation cable with 0.8 mm core diameter! Only bus telephones with ZPS/ZPSF 850-... located in the same line can be supplied by one line rectifier. Combined operation of BTC 850-... and BFC 850-... is possible.

#### Current consumption and ranges with supplementary power supply

Voltage range: 20–30 V DC

Power supply with NG 602-...	Max. conductor length/Distance of the supplementary supply			
BTC 850-... with ZPS 850-... Current consumption 100 mA	1st device 260 m	2nd device 130 m	3rd device 80 m	4th device not possible
BFC 850-... with ZPSF 850-... Current consumption 100 mA	1st device 260 m	2nd device 130 m	3rd device 80 m	4th device not possible



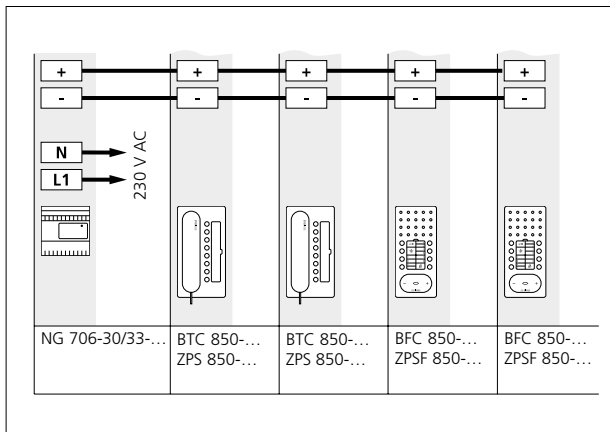

A maximum of 8 ZPS/ZPSF 850-... units can be supplied by a NG 706-30/33-... line rectifier. The maximum current of the 30 V DC direct voltage from the NG 706-30/33-... is 1100 mA. The specified ranges only apply to the external power supply to the devices, not to the range of the In-Home bus. Ranges applicable for J-Y(St)Y or YR installation cable with 0.8 mm core diameter! Only bus telephones with ZPS/ZPSF 850-... located in the same line can be supplied by one video line rectifier. Combined operation of BTC 850-... and BFC 850-... is possible.

<b>Power supply with NG 706-30/33-... Max. conductor length/Distance of the supplementary supply</b>					
BTC 850-... with ZPS 850-...	1-4th devices	5th device	6th device	8th device	
Current consumption 100 mA	300 m	250 m	200 m	130 m	
BFC 850-... with ZPSF 850-...	1-4th devices	5th device	6th device	8th device	
Current consumption 100 mA	300 m	250 m	200 m	130 m	

## 8 Supplementary functions

### Parallel door call

Parallel programming of several bus telephones to one call button.

• On principle, all combinations can be programmed with BPS 650-...

• Manual programming with 8 BTC/BFC 850-... units is possible if from the 3rd bus telephone each BTC 850-... uses a ZPS 850-.../each BFC 850-... uses a ZPSF 850-...

• BTS 850-... and AIB 150-... can only be programmed as 1-4 bus telephones

• Programming must start at the bus telephones which do not have any additional power supply connected.

Manual prog.	Prog. with BPS	Bus telephones 1-2	Bus telephones 3-4	Bus telephones 5-8
X	X			
X	X			
X	X			
	X			
	X			
X	X			
X	X			
	X			
X	X			

### Device overview



AIB 150-...



BTS 850-...



BTC 850-...



BTC 850-... + ZPS 850-...



BFC 850-... + ZPSF 850-...

**Supply of Jung audio indoor stations**

A maximum of 15 Jung audio indoor stations can be supplied by a NG 706-30/33-... line rectifier. The maximum current of the 30 V DC direct voltage from the NG 706-30/33-... is 1100 mA.

The specified ranges only apply to the external power supply of the devices, not to the ranges of the In-Home bus. Ranges applicable for J-Y(St)Y or YR installation cable with 0.8 mm core diameter! Only devices which are located in the same line can be supplied by one line rectifier.

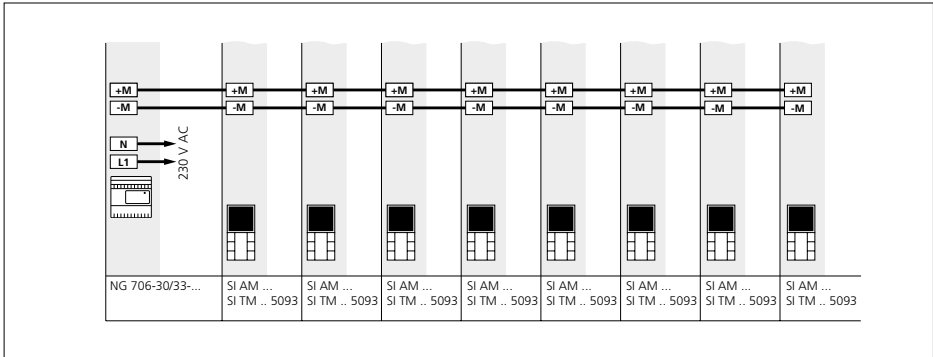

<b>Power supply with NG 602-...</b>	<b>Max. conductor length/Distance of the supply</b>		
SI AM ...	1 device	2 device	3-8 device
SI TM .. 5093	90 m	50 m	Further additional power supply
Current consumption 75 mA			

<b>Power supply with NG 706-30/33-...</b>	<b>Max. conductor length/Distance of the supply</b>							
SI AM ...	1-3th devices	4 device	5 device	6 device	7 device	8 device	15 device	
SI TM .. 5093	300 m	250 m	200 m	180 m	150 m	130 m	50 m	
Current consumption 75 mA								

## 8 Supplementary functions

### Storey call parallel switching

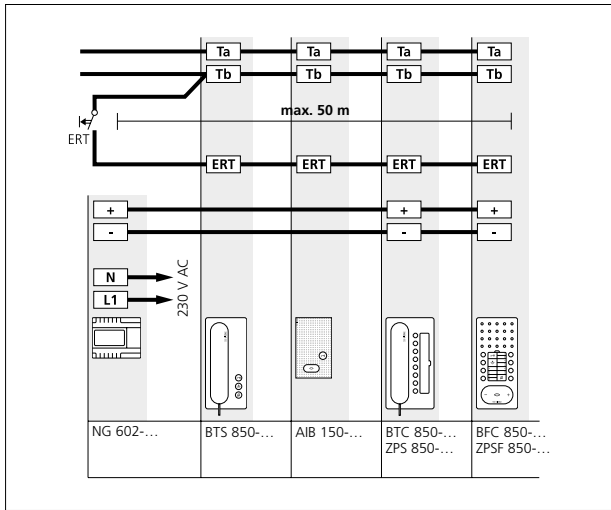

### Storey call parallel switching

The storey call button (ERT) is used to call into the apartment from an apartment door. To call several bus telephones, the ERT terminal can be connected in parallel, e.g. office floor with 4 bus telephones with one storey call button at the storey entrance.

A maximum of 8 bus telephones can be rung in parallel using a storey call button.

1. If the bus telephones are additionally supplied via parallel switching accessory ZPS 850-..., then all the bus telephones ring simultaneously.
2. If the bus telephones have no additional power supply, the storey call can be heard in sequence at the telephones.

**The complete range of the storey call amounts to 50 m with an 0.8 mm core diameter.**

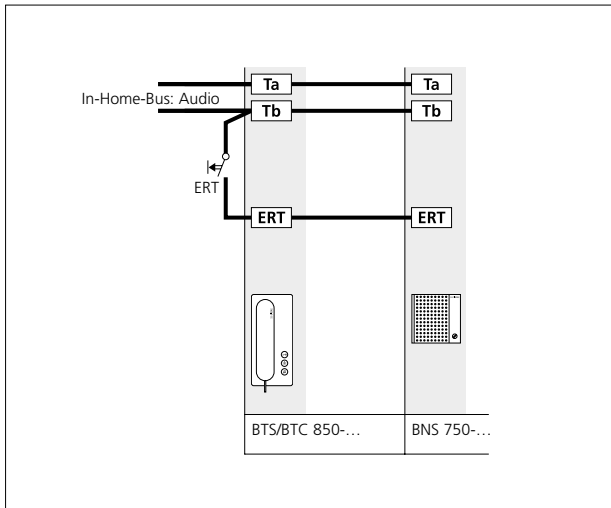

### Bus secondary signal unit

#### BNS 750-...

Additional bus secondary signal unit in parallel at a bus telephone. Signalling door calls and storey calls. Following the installation, the door call must be programmed at both devices.

For more information, see page 73

## Supplementary contact, radio chime, pilfer safeguard

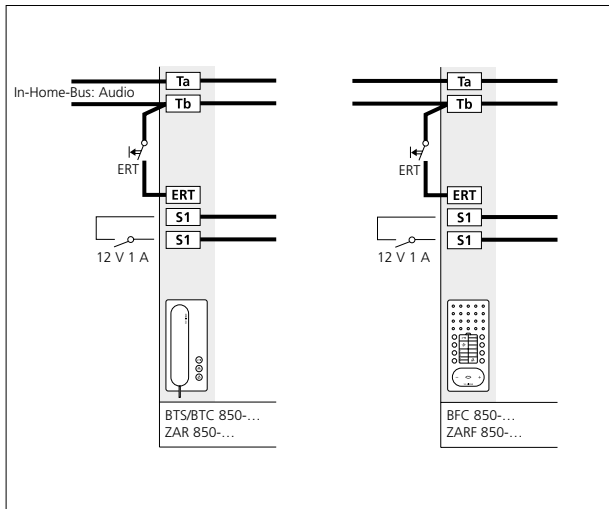

### Supplementary contact in the bus indoor device

The bus indoor devices provide an additional contact at terminals S1/S1.

Actuation of an additional signaling device such as a radio chime or optical display of the door call. If the contact is required in the sub-distributor, the door call can be programmed to a contact at a BSE/BSM 650-...

As-delivered status, secondary signal unit function 1 second, can be multifunctionally reprogrammed using BPS 650-...

Using the BPS 650-... the contact can also be programmed to a button of the bus telephone, to switch it to potential-free status.

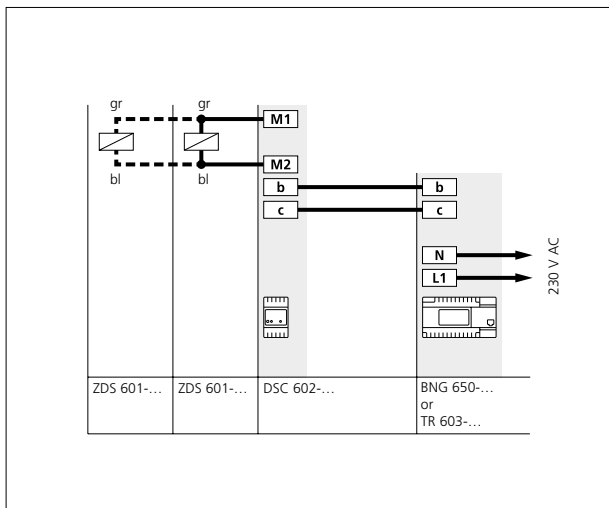

### Pilfer safeguard for Vario modules

Bistable magnet for integration in mounting frame MR 611-...

To secure valuable modules such as camera modules, code lock modules or to ensure tamper-proof operation of the door release.

A stable metal plate locks the opening mechanism and prevents modules from being removed.

The magnets are opened and locked in the sub-distributor at pilfer safeguard controller DSC 602-... A maximum of 2 ZDS 601-... units can be operated at one DSC 602-...

### Range

Maximum conductor length between DSC 602-... and ZDS 601-... with 0.8 mm core diameter 100 m.

## 8 Supplementary functions

### Staircase light/Outside light

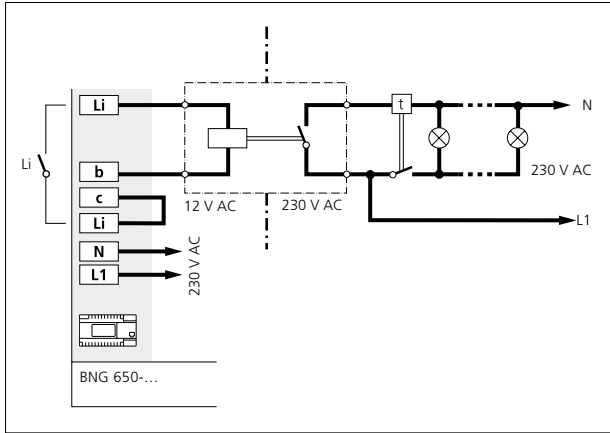

#### Light actuation

The light button in the bus indoor devices or BTLM 650-... is used to actuate the light contact in the bus line rectifier BNG/BVNG 650-... . Following completion of the installation, this function is active without any further programming. To actuate the staircase and/or outside light, according to VDE regulations a light current relay or time relay must be interconnected.

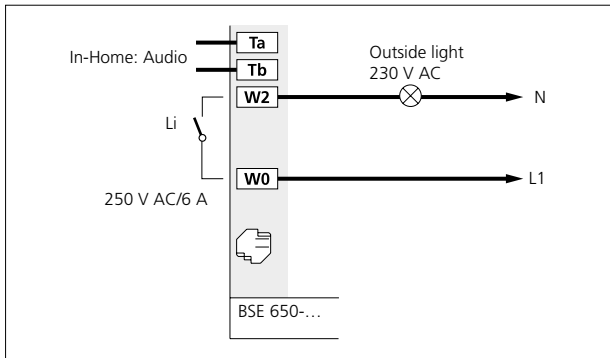

#### Light actuation

Actuation of an additional lamp via BSE 650-... Max. contact load 230 V AC, 6 A.

## 9 Servicing

### Restart, exchange, operating mode

#### Restarting the system

A restart of the complete system is known as a Power-ON-Reset.

Switch off the power supply to the bus line rectifier, wait for a few seconds, switch the power back on. The system restarts, and all bus users are initialized again. The system programming is retained.

#### Delete programming

- Disconnect terminals Ta and Tb
- Change the address of the bus line rectifier, i.e. change the address from 1 to another address which is still unassigned, e.g. 2. In multiple-line systems, ensure that no address has been assigned more than once. (no waiting time required, as no device is connected at the line)
- Connect bus cores Ta and Tb

#### Restoring the as-delivered status

All programmed users in the bus line rectifier are deleted, the system must be subsequently reprogrammed. Procedure:

- Switch off the supply voltage to the bus line rectifier.
- Disconnect terminals Ta and Tb
- Hold down the programming mode button
- Switch on the voltage and release the programming mode button after appr. 5 seconds.
- Function LED 1 flashes evenly
- Wait until the LED 1 display returns to show the normal operating status.
- Change the address of the bus line rectifier, e.g. set address 1 to 2. In multiple-line systems, ensure that no address has been assigned more than once.
- Connect bus cores Ta and Tb
- The system is reinitialized.
- Function LED 1 flashes again
- When LED 1 indicates a return to normal operational readiness, set the address of the bus line rectifier back to the original value.
- The system can now be programmed again.

#### Exchanging bus telephones in an existing system

If an already programmed bus telephone has to be exchanged, the following procedure must be adhered to:

- Switch off the bus line rectifier voltage
  - Disconnect the existing bus telephone terminals
  - Connect the new bus telephone
  - Switch the bus line rectifier on again and wait until the system ramp-up is completed.
  - Program new users (door calls, internal calls etc.) with manual programming or using BPS 650-...
- When exchanging existing bus telephones for AIB 150-..., BFC 850-..., the range is reduced to 130 m with a 0.8 mm core diameter when using BSG 650-...

#### Exchange BNG 650-... for BNG 650-...

The existing system programming is retained.

- Switch off the voltage
- Disconnect the BNG 650-... and connect the new BNG 650-...
- Hold down the programming mode button, switch on the power.
- LED 1 flashes evenly - wait until the LED display goes out, then release the button.
- When the LED 1 indicates the normal operating mode again, the previous system status has been restored.

#### Exchanging an existing BSG 650-... for a BNG 650-...

The existing system programming is retained.

When exchanging the BNG 650-... in existing systems, the setting of the operating mode switch must be noted. The setting depends on the device types installed in the existing system. If different device types are used together in an existing installation, the operating mode must be set to switch setting 1.

In switch setting 1 the operating current is limited to max. 300 mA, in order not to damage the first-gen-

eration bus users. The performance features on the In-Home bus are not fully available in switch setting 1. The following functions are not available:

- Status display of the LED for feed-back from BEM/BSE 650-...
  - Doormatic
  - Call forwarding
  - Parallel calls only possible up to 2 bus telephones
- Switch setting 2 has the same function as the Norm setting.

## 9 Servicing

Restart, exchange, operating mode

### Operating mode switch

#### 1-Norm-2 BNG 650-...

Switch setting 1 "Reverse compatible"	Switch setting "Norm"
BTS 750-0	AIB 150-...
BTC 750-0	BTS/BTC 850-...
BNS 750-0	BFS/BFC 850-...
BTLM 650-0/-01	BTS 750-02
BTLE 050-0/-01	BTC 750-02/-03
BSM 650-0	BNS 750-02
BIM 650-0	BTLM 650-02/-03/-04
DCA 650-0	BTLE 050-02/-03/-04
	BSM 650-02
	BIM 650-02
	BSE 650-0
	BEM 650-0
	DCA 650-02
	CA/CAU 850-...
	CSA/SBA/STA 850-...
	DCI 600-0
	SI 4 A ..
	SI AI ...











In the case of devices which are not listed here, the position of the operating mode switch is not relevant, e.g. bus call button module BTM 650-...

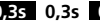
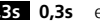

















## LED displays BNG 650-...

The two displays LED 1 and LED 2 at the bus line rectifier indicate functions for operation and possible faults in the In-Home bus. The following table indicates the possible displays.

### Display LED 1 "Operation"

LED flashes evenly (System ramp-up)						etc.	
LED flashes short on, long off (Operation display, system is functional)	1s		1s		1s		etc.
LED flashes short on, long off (Programming mode active)		2s		2s		etc.	
LED remains alight (Plug+Play programming is active)							

### Display LED 2 "Fault"

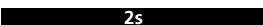
LED flashes long on, short off (Own address incorrect)			0,3s			etc.			
LED flashes long on, short off short on, short off, long on (More than 31 users in the line)			0,3s				etc.		
LED remains alight (Address error at other BNG/BVNG 650-...)									
LED flashes evenly In multiple line systems, more than one ZBVG 650-... connected								etc.	
LED flashes unevenly Unsuitable device connected in Plug+Play mode	0,3s		0,2s			0,3s		0,2s	etc.
LED flashes evenly No BTLM/BTLE connected in Plug+Play mode					2s	etc.			

## 9 Servicing

### Measured values

#### Measured values at the In-Home bus: Audio, to be measured with a digital multimeter

<b>Idle status</b>	<b>min.</b>	<b>max.</b>
Voltage Ta/Tb at bus line rectifier BNG 650-...	26 V DC	29 V DC
Voltage at most distant user	16 V DC	
Current consumption bus indoor devices	6 mA	
Current consumption bus door loudspeaker	10 mA	
<b>Call status</b>		
Voltage Ta/Tb at bus line rectifier BNG 650-...	28 V DC	32 V DC
Voltage at most distant user	16 V DC	
Current consumption bus indoor devices (volume dependent)	6 mA	15 mA
<b>Speech mode</b>		
Voltage Ta/Tb at bus line rectifier BNG 650-...	26 V DC	29 V DC
Voltage at most distant user	16 V DC	
Current consumption bus indoor devices	30 mA	
Current consumption bus door loudspeaker	80 mA	
<b>Multiple line system</b>		
Voltage Sa/Sb measured at the BNG 650-...	15 V DC	17 V DC
<b>PRI 602-... USB</b>		
Voltage b/c	11 V AC	15 V AC
Voltage Sa/sb	15 V DC	17 V DC
Voltage Da/Db	0.3 V DC	

## 10 Glossary, Index

Address	9, 21	AIB 150-...	15
As-delivered status	95	BEM 650-...	13, 85
Outside light	94	BEM 651-...	13
Exchange	95	BFC 850-...	16
Operating mode switch	52, 95	BIM 650-...	13
Classic	11, 30	BNG 650-...	12
Compact	11, 26	BNS 750-...	18
Single line system	6	BPS 650-...	14, 84
Storey call	40, 92	BRMA 051-...	10
Troubleshooting	98	BSE 650-...	13, 85
Handsfree	15	BSE 651-...	13
Radio chime	19, 93	BSM 650-...	13, 85
Commissioning	52	BTC 850-...	15
Intercom functions	34	BTLE 051-...	10
Internal call	40	BTLM 650-...	10
LED display	40	BTM 650-...	10
Conductor length	6	BTS 850-...	15
Light button	40	CA 850-...	11
Multiple line system	8	CAU 850-...	11
Measured values	98	CL A xx B-01	11
Secondary signal unit	16, 92	COM 611-...	10
Storey call parallel switching	92	DCA 650-...	14
Plug+Play	82	DRM 612-...	10
Programming	48	DSC 602-...	93
Reset	95	NG 602-...	12
Reset Plug+Play	80	NG 706-30/33-...	12, 89
Call silencing	48	PRI 602-...	14
Call tone configuration	48	PRI 602-... USB	14, 84
Servicing	98	SI 4 A ..	17, 44
Status display (via LED)	48	SI Al ...	22, 44
Steel	11, 32	STL	11
Control functions	13, 48, 85	TÖ 615-...	86
Teach-in	48	TR 603-...	12
Users	4	ZAR 850-...	19
Door dialling	48	ZARF 850-...	19
Door loudspeaker	10	ZBVG 650-...	12
Doormatic	48	ZDS 601-...	93
Door release	86	ZPS 850-...	19, 88
Door call	48	ZPSF 850-...	19, 88
Door call acceptance	48	ZTC 800-...	18
Door call forwarding	48	ZTS 800-...	18
Time for light contact	48		

Technical additions or printing errors do not constitute grounds for compensation claims.

To supplement this system manual, you will find the latest edition in the download area of our website on [www.siedle.com](http://www.siedle.com)

**Customer service in the Furtwangen factory**  
+49 7723 63-434

# SSS SIEDLE

S. Siedle & Söhne  
Telefon- und Telegrafengeräte OHG

Postfach 1155  
78113 Furtwangen  
Bregstraße 1  
78120 Furtwangen

Telefon +49 7723 63-0  
Telefax +49 7723 63-300  
[www.siedle.de](http://www.siedle.de)  
[info@siedle.de](mailto:info@siedle.de)

© 2015/09.21  
Printed in Germany  
Best.-Nr. 210011022-00 EN